

- Heavy 16 gauge steel construction
- Powder coated paint finish
- Steel block fin element
- All units equipped with manual reset thermal limit switch
- Vane Axial fan blade produces 245 CFM
- Dual wattage and voltage units available for 208/240 volts
- Surface Mounting Frames available for non-recessed and semi-recessed applications
- Units built with factory installed Disconnecting Tamper-Proof Thermostats, and Automatic Fan Delay

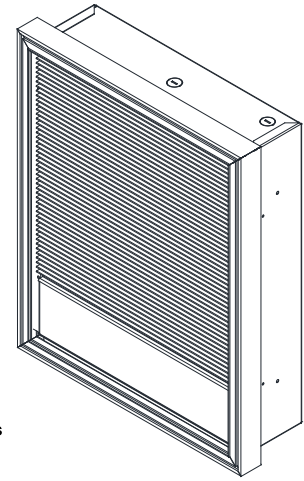

Factory Installed Accessories

Units with transformers must have a contactor. A control transformer with 120V secondary is available on all 3-phase models, 208V/240V 1-phase units up to 3KW, and up to 4KW on 277V. All heaters must be installed with a wall box.

Product Specifications

Contractor shall supply and install heavy duty wall mounted forced air electric heaters of the wattage, voltage and phase as specified. The heater shall so be designed to provide an even distribution of heated air to the space to be heated by drawing return air in the peripheral area of the heater across and through the element which shall then be discharged from the center section of the heater by means of an electric motor and axial flow fan blade. Heaters shall be recessed type to extend no more than 1 ½" from the finished wall or surface mounted to extend no more than 5 ¾" from the finished wall or semi-recessed type to extend no more than 3 ½" from finished wall or semi-recessed type to extend no more than 2 ½" from finished wall.

ENCLOSURE:

Heater front shall withstand 10.8 ft. lbs. (324 poundals) impact and 400 lbs. static force applied to an 8 sq. in. area at center grille location with less than ¼" permanent distortion. The combination return and supply grille assembly shall be constructed of ¼" x ¾" rounded edge horizontal steel louvers which shall be spaced for maximum opening of ¼". Louvers shall be welded at every intersection to three evenly spaced 1/16" diameter vertical members and completely framed in a heavy gauge natural anodized Aluminum extrusion. Front assembly shall be attached to the chassis by hidden tamper-resistant (Allen-head) machine screws. All other parts shall be 16 gauge steel Zinc coated, both sides finished in a high gloss or bronze colored baked powder coat finish.

MOTOR:

Motor shall be a permanently lubricated unit bearing, totally enclosed shaded pole type with impedance protection. Motors shall operate at no more than 1400 RPM and shall be same voltage as the heater. A protective shield shall surround the motor to separate return air from heated air.

PERFORMANCE:

Heaters shall have a rating of 245 CFM at 660 F.P.M. with a maximum temperature rise of 73°F.

ELEMENTS:

Element assemblies shall consist of two or three corrosion resistant steel sheathed type elements mechanically bonded to common corrosion resistant steel fins. Each sheathed element shall consist of helically coiled Nickel Chromium alloy resistant wire completely embedded in and surrounded by Magnesium Oxide, enclosed and wedged into corrosion resistant steel sheaths. Elements shall have 2" cold conductor pins extending into the sheath and shall have a density of no more than 60 Watts per inch.

THERMAL OVERLOAD:

Heaters shall be equipped with a "manual reset" thermal overload which disconnects elements and motor in the event normal operating temperatures are exceeded. For safety, if opened due to abnormal temperature, thermal overload shall remain open until manually reset. Automatic reset thermal overloads which allow the element to continue to cycle under abnormal conditions will not be accepted.

APPROVAL:

Heaters shall be ETL Listed.

OPTIONAL CONTROL SYSTEMS:

Heaters shall be operated from wall-mounted, line voltage, heavy-duty (tamper-proof) thermostats. Heaters with built-in, pre-wired contactors shall be operated from wall-mounted, line voltage, pilot duty (tamper-proof) thermostats. Heaters built with, pre-wired contactors (and control transformers) shall be operated from wall-mounted, pilot duty (24V) or (120V) wall-mounted tamper-proof thermostats. Heaters shall be controlled by integrally mounted thermostats. Thermostats shall be heavy-duty, hydraulic type with a temperature range of 40°F-120°F for double pole units and 40°F-120°F for three pole units and with remote sensing bulb placed in the return air. Thermostats shall be electrically rated at least 125% of heater rating. Thermostats shall be electrically rated at least 125% of heater rating. Thermostats shall also act as a disconnect by breaking all ungrounded conductors in the OFF position. (Thermostat control knob shall be covered by a 16 gauge tamper-proof access plate to prevent adjustment by unauthorized personnel.)

CONTACTORS:

Where required, heaters shall be equipped with heavy-duty, definite purpose contactors with flame path separators and dust covers. Contactors shall cycle all ungrounded conductors. Contactors shall have holding coils (of the same voltage as the heater) or (120 Volts) or (24 Volts).

CONTROL TRANSFORMERS:

Heater shall be equipped with a Class 2 control transformer, sealed rating of 20 VA, to supply control circuits of (24 Volts) or (120 Volts). (120 Volt secondaries not available in single phase heaters over 3 KW).

CIRCUIT BREAKERS (3450 Series Only):

Heaters shall be equipped with built-in circuit breakers in order to allow the heaters to be supplied from feeder taps. A separate switch providing a positive off for control circuits shall be included where required. Circuit breakers and control switches shall be arranged so that all line side conductors will be separately enclosed when heater front is removed for servicing so that no current carrying parts are accessible without the use of additional tools.