

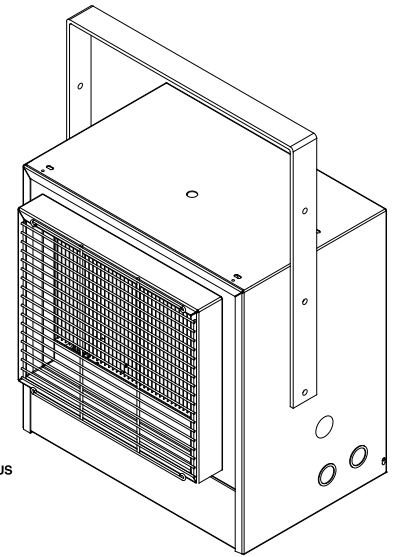

MADE IN THE U.S.A.

# 5700 SERIES CONFINED SPACE PLENUM HEATER

CUSTOMER		DATE:	
PROJECT			
LOCATION			
ARCHITECT			
ENGINEER			
CONTRACTOR			
SUBMITTED BY			
APPROVED BY			
APPROVED BY			



## SUBMITTAL DATA SHEET

QTY	MODEL	TAG	WATTAGE	VOLTS	PHASE	AMPS	DISCONNECT	THERMOSTAT	OPTIONS

NOTES/SPECIAL INSTRUCTIONS:

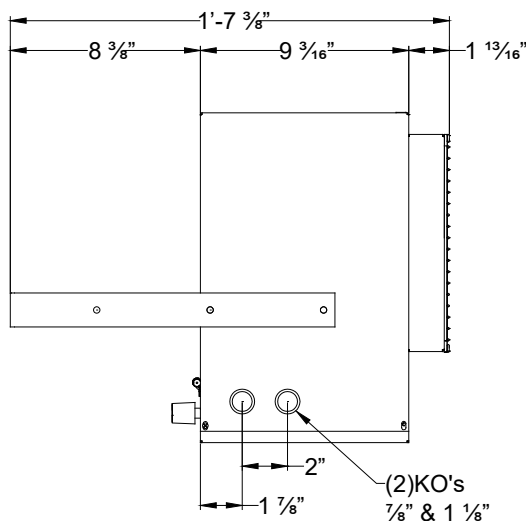
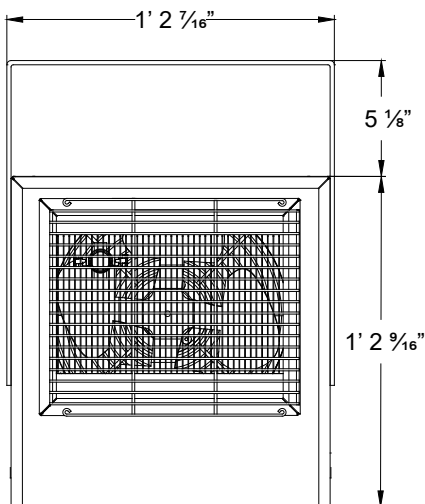

CERTIFIED TO  
CAN / CSA C 22.2  
NO. 236-11

CONFORMS TO  
ANSI / UL 1995

- 20 Gauge steel construction
- Powder coated paint finish
- Heavy duty block fin heating element
- Equipped with Automatic over-heat limit protection
- Zero clearance for wall, ceiling, and floor mounting with appropriate inlet and outlet clearances
- Bracket included. Can be mounted with 3/8" threaded rod (field supplied)
- Selectable wattage 1874 to 5000 on single phase model
- Optional 30 Amp field installed disconnect
- 24 Volt control circuit on three phase model with hydraulic thermostat

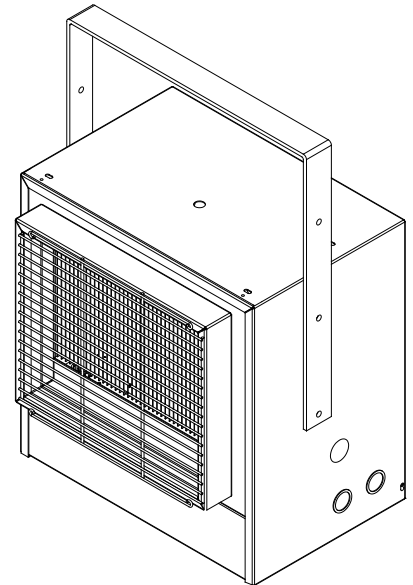

### Standard Models

MFG CATALOG NUMBER	MFG MODEL NUMBER	WATTS	BTUs	VOLTS	PHASE	AMPS	TEMP RISE	TEMP RANGE	AIR THROW	CFM	WT. (LBS)
07262402	HF5705T	5000	17065	240	1	21	57 °F	(40 °F-120 °F)	16'	275	32
		4165	14215			17	48 °F				
		3332	11365			14	38 °F				
		2500	8533			10	29 °F				
	3750	12798	208	1	18	43 °F	(40 °F-120 °F)				
					3123	10659		15			
07262502	H3H5705T	2500	8553	208	3	12	29 °F	(40 °F-110 °F)			
		1874	6396			9	21 °F				
07262602	P3P5705T	3750	12799	208	3	10.4	43 °F	(40 °F-110 °F)			
		5000	17065	240	3	12	57 °F				
07262602	P3P5705T	5000	17065	480	3	6	57 °F	(40 °F-110 °F)			
07073602	DCS-MT303	Optional Field Installed Disconnect Switch, 30 Amp @ 600Volts									