



**TPI**  
**CORPORATION**  
*America's Comfort Conditioning Company*

# 2024

## Electrical Products Catalog

**Ventilation - Fans - Industrial Lighting**



TEL: 1-800-682-3398 | [www.tpicorp.com](http://www.tpicorp.com) | [productsearch.tpicorp.com](http://productsearch.tpicorp.com)  
© Copyright 2024

LIGHTING

VENTILATION

CATEGORY	PAGE
<b>INDUSTRIAL CIRCULATORS</b>	
24" & 30" Assembled Maximum Duty	2
20" to 36" Assembled Circulator Heads & Mounts	3
20" 24" & 30" Unassembled Circulators	4
20" 24" & 30" Specialty Circulator Heads	5
Components - Motor Comparisons	6
Air Circulators - Motor Comparisons	7
<b>COMMERCIAL CIRCULATORS</b>	
20", 24" & 30" Commercial Non-Osc. Circulators	8
20", 24" & 30" Commercial Oscillating Circulators	8
<b>COMMERCIAL BLOWERS</b>	
36" 42" & 48" Belt Drive Portable	9
24" 30" & 36" Direct Drive Portable	9
<b>INDUSTRIAL BLOWERS</b>	
30" 36" & 42" Direct Drive Portable	10
48" Direct Drive Portable	10
36" 42" & 48" Belt Drive Portable	11
30" 36" & 42" Direct Drive Suspension	12
36" 42" & 48" Belt Drive Suspension	12
24" & 30" Mini	13
Heavy Duty Square Belt Drive Portable	13
High Velocity	14-15
Heavy Duty Direct Drive	16
Heavy Duty Permanent Mount Direct Drive	17
<b>WORKSTATION FANS</b>	
Industrial Floor	18
Corrosion Resistant Industrial Floor	18
Industrial Mounted	19
Outdoor Rated Yoke Mount	19
Commercial Floor	20
Oscillating Office	20
Wall Mounted With Pivoting Arm	21
Low Velocity "Special Application"	21
<b>CEILING FANS</b>	
Industrial Ceiling Fans	22

CATEGORY	PAGE
<b>EXHAUST FANS &amp; GUARDS</b>	
Shutter Mounted Direct Drive	23
Guard Mounted Direct Drive	24
Venturi Mounted Direct Drive	25
Commercial Belt Drive - (Fans & Shutters)	26
Industrial Direct Drive	27
Industrial Belt Drive	28
Heavy Duty Direct Drive	29
Heavy Duty Belt Drive	30
Cabinet Exhaust Fans With Shutters	31
Accessories / Heavy Duty Shutters	32
Cabinet Accessories / Guards	33
Cabinet Exhaust Fan Package Options	34
Weather Hood	34
<b>ROOF VENTILATORS</b>	
Insulated Roof Curbs	35
Belt Drive Hooded Roof Ventilator	36
Direct Drive Roof Ventilator	37
Belt Drive Roof Ventilator	38
<b>TUBEAXIAL DUCT FAN</b>	
Direct Drive & Guards	39
Belt Drive	40
<b>ATTIC FANS</b>	
Roof Domes, Gable Fans, Attic Fans	41
<b>INDUSTRIAL LIGHT PRODUCTS</b>	
Loading Dock Lights	42
Modular Loading Dock Lights	43
Machine Tool Lights	44
<b>PRODUCT INDEX</b>	

TPI Corporation provides a limited warranty of materials and workmanship for a period of (i) ten (10) years for elements in 2900 Series baseboard heaters, (ii) two (2) years for Thermostats and Controls, (iii) five (5) years on HD and HDH series fans, (iv) three (3) years on UHP and IHP series fans, (v) and twelve (12) months for all other products, with the warranty period commencing on the original date of purchase. The TPI warranty is limited to materials manufactured and work performed by TPI Corporation, and does not include damage or failure caused by acts of God, abuse, misuse, connected to or placed on other than rated voltage, abnormal usage, faulty installation, failure to follow suggested maintenance procedures enclosed with the product, improper maintenance or any repairs other than those provided by an authorized TPI Corporation service center. For the name of your nearest authorized TPI Corporation service center, please write to TPI Corporation, P.O. Box 4973, Johnson City, Tennessee, 37602 or call 1-800-682-3398.

During the warranty period, TPI Corporation will, at its sole option, repair or replace any defective parts or products returned, freight prepaid, to the TPI Corporation factory or such other location as TPI Corporation may designate. No parts or products will be accepted for repair or replacement without prior authorization from TPI Corporation and a return merchandise authority (RMA) number issued by TPI Corporation. Returned products must be packaged carefully and TPI Corporation shall not be responsible for damage in transit. When returning parts, the owner must provide the model number of the product and nature of difficulty being experienced.

This warranty does not obligate TPI Corporation to bear the cost of labor in replacing any assembly, unit or component part thereof, nor does TPI Corporation assume any liability for secondary charges, expenses for installing or removal, freight or damages. There will be charges rendered for product repairs made after the warranty period has expired. Proof of purchase, including date, must accompany request for in-warranty service. This warranty gives you specific legal rights and you may have other rights, which may vary, from state to state.

Except for the limited warranty provided in the foregoing paragraph, all parts and products sold by TPI Corporation are sold 'as is', 'where is', and without any other warranty of any kind or nature, whether express, implied, or statutory and including, without limitation, any implied warranty of specific performance or merchantability.

Under no circumstances, even with respect to claims covered by the foregoing warranty, will TPI Corporation be responsible for any incidental, consequential, special, or punitive damages of any kind or nature arising from or related to the parts or products sold by TPI Corporation.

In any event, TPI Corporation's maximum liability shall not in any case exceed the purchase price for the part or product claimed to be defective.

You hereby expressly agree to waive any and all rights to a trial by jury with respect to any product manufactured or supplied by TPI Corporation.

Ventilation Products Warranty Coverage	
Series HD or HDH fans	5 Years
Series UHP or IHP fans	3 Years
All other ventilation products	1 Year

**RETURN POLICY:**

Requests for returns of non-defective standard stock units may incur testing and repackaging charges if units are not in like new condition. Requests for returns of build to order items are subject to cancellation charges prior to shipment and up to a 100% restocking charge after shipment. This also applies to any standard model with factory installed control options or other custom features. Changes made to custom products during production may incur labor charges. Please consult factory for details on any return or change order.

**TPI COMMERCIAL CIRCULATORS STATEMENT:**

TPI Commercial circulators have been developed to equal the imported circulators that are sold by big-box retail stores and some catalogers. Because these circulators do not have totally enclosed motors, they should be used in clean, dry commercial applications - such as schools, shops, offices, and warehouses.

**Note: Prices subject to change without notice.**

# TPI Industrial Assembled Maximum Duty Circulators

## Features



**HDH Series**

- Steel construction with safety yellow textured epoxy powder coated finish
- Direct-drive, Totally Enclosed Air-Over (TEAO) motor generating up to 8,000-CFM's
- Aluminum 4-paddle blade system with steel hub and cast aluminum spider connections
- HDH-Series contains a pull-chain switch and 12' long SJT-Type cord with grounded plug
- HDH-JR Series contains a 12' long SJT-Type cord with grounded plug and 18" long drop-down cord assembled with an electrical (off, on/low/high) switch enclosure
- Fully-assembled Non-Oscillating fan heads in 24" or 30" diameter sizes
- 5-year motor warranty
- Made in the U.S.A. with domestic and foreign components

## Motor Specifications

- 2-speed
- 1-phase, 120V
- Permanent split capacitor
- Frame size: 48
- 1/2 HP
- Ball bearing
- Totally enclosed, permanently lubricated
- 1/2" Shaft

## DIMENSIONS

24"	27" Diameter x 14.5" Depth
30"	33.5" Diameter x 14.5" Depth

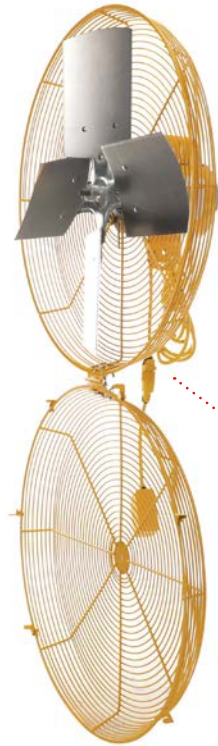

Hinged Guard



**HDH-JR Series**



Drop-Down Switch



Wall Mount  
see pg. 6



Pedestal Mount, see pg. 6



**WARNING:** This product can expose you to chemicals including nickel which is known to the State of California to cause cancer, and chromium, which is known to the State of California to cause birth defects and/or reproductive harm. For more information go to [www.P65Warnings.ca.gov](http://www.P65Warnings.ca.gov).

## Standard Models

ASSEMBLED FAN HEAD		BLADE SIZE	SWITCH TYPE	HP	CFM* / RPM		VELOCITY PROFILE	AMPS	WT. (LBS)	LIST
MFG CATALOG NUMBER	MFG MODEL NUMBER				CFM / AREA SQ FT					
08744402	HDH 24-JR	24"	Drop Down	1/2	5600 / 1100	4900 / 800	7500 / 260	3.5	44	<b>1029</b>
08744602	HDH 30-JR	30"			6800 / 1100	6000 / 800	8000 / 270	4	48	<b>1059</b>
07960702	HDH 24	24"	Pull Chain		5600 / 1100	4900 / 800	7500 / 260	3.5	44	<b>943</b>
07960802	HDH 30	30"			6800 / 1100	6000 / 800	8000 / 270	4	48	<b>965</b>

\*Measured 2 feet from face of fan

TPI offers six factory assembled and tested fan mounts that can be used with any of the non-oscillating TPI Industrial heads.

# TPI Industrial Assembled Circulator Heads and Mounts

## Features

- Steel construction with silver/gray powder coated; steel motor housing painted black
- Direct drive, Totally Enclosed Air-Over (TEAO) motor generating up to 12,000-CFM's
- Aluminum 3-paddle blade system with steel hub and cast aluminum spider connections
- All models contain a pull-chain switch and 12' long SJT-Type cord with grounded plug
- All models, except **HDH-36**, contain self-locking retaining clips to secure front/rear grills and meet OSHA safety requirements
- **HDH-36 model is preassembled and ships altogether in one carton; operates at single speed, contains interlocking front/rear grills and includes mounting bracket**
- HDH-GJR Series contains a 12' long SJT-Type cord with grounded plug and 18" long drop down cord assembled with an electrical (off, on low/high) switch enclosure
- Fully-assembled ready for plug-&-play operation offered in non-oscillating (stationary) and oscillating fan heads in 20", 24" or 30" diameter sizes; mounts sold separately
- Oscillating models rotates in a 90° arc or can be locked in a fixed position
- Metal gears in the oscillating model allow the fan to operate at a maximum 30° downward tilt
- Motor warranty ranges from 1, 3 and 5 years
- Made in the U.S.A. with domestic and foreign components



**ACM-IHP-HDH Series**



**HDH-G-JR Series**  
Drop-Down Plug and Hinged Guard



**ACH-O Series**  
Oscillating Motor

## Motor Specifications

- 2-Speed
- 1 Phase, 120V
- Ball bearing
- Frame size: 48
- Totally enclosed
- Permanent split capacitor
- Permanently lubricated
- ½" Shaft



DIMENSIONS	
20"	22" Diameter x 14.5" Depth
24"	27" Diameter x 14.5" Depth
30"	33.5" Diameter x 14.5" Depth

**WARNING:** This product can expose you to chemicals including nickel which is known to the State of California to cause cancer, and chromium, which is known to the State of California to cause birth defects and/or reproductive harm. For more information go to [www.P65Warnings.ca.gov](http://www.P65Warnings.ca.gov).

## Standard Models

H.P.	BLADE SIZE	MFG MODEL NUMBER	MFG CATALOG NUMBER	FAN HEAD TYPE	CFM*	VELOCITY PROFILE	RPM	AMPS	WT. (LBS)	LIST
						CFM / Area Sq Ft				
1 Year Warranty										
Industrial 1/4	20"	ACH 20	08684702	STATIONARY	3000 / 2600	5000 / 200	1100 / 900	2.4	39	<b>482</b>
	24"	ACH 24	07961602		3800 / 3400	6000 / 240	1100 / 800	2.5	40	<b>542</b>
	30"	ACH 30	07961702		4300 / 3800	7200 / 250	1100 / 800	2.7	44	<b>559</b>
3 Year Warranty										
High Performance 1/3	24"	IHP 24-H	07989802	STATIONARY	4300 / 3900	6000 / 240	1100 / 800	2.8	40	<b>690</b>
	30"	IHP 30-H	07989902		5400 / 4700	7200 / 250	1100 / 800	3	44	<b>722</b>
5 Year Warranty										
Heavy Duty 1/2	24"	HDH 24-G	08539202	STATIONARY	5600 / 4900	7500 / 260	1100 / 800	3.5	44	<b>905</b>
	30"	HDH 30-G	08528602		6800 / 6000	8000 / 270	1100 / 800	4	48	<b>934</b>
	24"	HDH 24-GJR	08745002		5600 / 4900	7500 / 260	1100 / 800	3.5	44	<b>1029</b>
	30"	HDH 30-GJR	08745102		6800 / 6000	8000 / 270	1100 / 800	4	48	<b>1059</b>
	36"	HDH 36	08197802		6970	12000 / 325	1100	5.2	90	<b>1019</b>
1 Year Warranty										
Industrial Oscillating 1/4	20"	ACH 20-O	08684802	OSCILLATING	3000 / 2600 / 2100	5000 / 200	1100 / 900 / 750	2.4	43	<b>730</b>
	24"	ACH 24-O	07963602		3800 / 3400 / 2700	6000 / 240	1100 / 900 / 750	2.5	44	<b>832</b>
	30"	ACH 30-O	07963702		4300 / 3800 / 3000	7200 / 250	1100 / 900 / 750	2.7	48	<b>863</b>

\*Measured 2 feet from face of fan

**HDH-36 Note: Wall mount only, mount included, unit imported to TPI specifications.**

**TPI offers six factory assembled and tested fan mounts that can be used with any of the non-oscillating TPI Industrial heads.**

# TPI Industrial Unassembled Circulators

## Features

- Unassembled packaged kits, include: motor, blade, guards & mount (pedestal or wall)
- Steel construction with silver/gray powder coated; steel motor housing painted black
- Direct drive, Totally Enclosed Air-Over (TEAO) motor generating up to 7,200-CFM's
- Aluminum 3-paddle blade system with steel hub and cast aluminum spider connections
- All models contain a pull-chain switch and 12' long SJT-Type cord with grounded plug
- All models contain self-locking retaining clips to secure front/rear grills and meet OSHA safety requirements
- HDH-GJR Series contains a 12' long SJT-Type cord with grounded plug and 18" long drop down cord assembled with an electrical (off, on low/high) switch enclosure
- Offered in Non-Oscillating (Stationary) and Oscillating fan heads in 20", 24" or 30" diameter sizes
- Oscillating models rotates in a 90° arc or can be locked in a fixed position
- Metal gears in the oscillating model allow the fan to operate at a maximum 30° downward tilt
- Pedestal pole adjusts the center of fan from 48" to 67" tall; bolts to 27" diameter steel dome with 5 bolts
- Motor warranty from 1 or 3 years
- Made in the U.S.A. with domestic and foreign components



**UHP-P Series**



**ACU-WO Series**

Oscillating Fan Head with Wall Mount



DIMENSIONS	
20"	22" Diameter x 14.5" Depth
24"	27" Diameter x 14.5" Depth
30"	33.5" Diameter x 14.5" Depth

**WARNING:** This product can expose you to chemicals including nickel which is known to the State of California to cause cancer, and chromium, which is known to the State of California to cause birth defects and/or reproductive harm. For more information go to [www.P65Warnings.ca.gov](http://www.P65Warnings.ca.gov).

## Motor Specifications

- 2-speed
- 1-Phase, 120V
- Ball bearing
- Frame size: 48
- Totally enclosed
- Permanent split capacitor
- Permanently lubricated
- 1/2" Shaft

## Standard Models

FAN TYPE		MAXIMUM DUTY	MAX AMPS	HIGH PERFORMANCE	MAX AMPS	INDUSTRIAL	MAX AMPS	OSCILLATING	MAX AMPS
MOTOR	HP	1/3		1/3		1/4		1/4	
CFM Velocity Profile / Area Sq. Ft.	20"	---	---	---	---	5000 / 200	2.4	5000 / 200	2.4
	24"	6000 / 240	2.8	6000 / 240	2.8	6000 / 240	2.5	6000 / 240	2.5
	30"	7200 / 250	3.0	7200 / 250	3.0	7200 / 250	2.7	7200 / 250	2.7
WARRANTY		3 YEARS		3 YEARS		1 YEAR		1 YEAR	

SIZE	TYPE of MOUNT	MFG CATALOG NUMBER	MFG MODEL NUMBER	LIST	MFG CATALOG NUMBER	MFG MODEL NUMBER	WT. (LBS)	LIST	MFG CATALOG NUMBER	MFG MODEL NUMBER	WT. (LBS)	LIST	MFG CATALOG NUMBER	MFG MODEL NUMBER	WT. (LBS)	LIST
20"	Pedestal Mount	---	---	---	---	---	---	---	08681402	ACU 20-P	72	<b>672</b>	08681602	ACU 20-PO	76	<b>710</b>
	Wall Mount	---	---	---	---	---	---	---	08681502	ACU 20-W	42	<b>548</b>	08681702	ACU 20-WO	46	<b>571</b>
24"	Pedestal Mount	08745202	UHP 24-PJR	<b>1120</b>	07990002	UHP 24-P	75	<b>934</b>	07962302	ACU 24-P	75	<b>696</b>	07964002	ACU 24-PO	79	<b>1055</b>
	Wall Mount	08745402	UHP 24-WJR	<b>944</b>	07990202	UHP 24-W	45	<b>763</b>	07962402	ACU 24-W	45	<b>580</b>	07964102	ACU 24-WO	49	<b>882</b>
30"	Pedestal Mount	08745302	UHP 30-PJR	<b>1145</b>	07990102	UHP 30-P	73	<b>965</b>	07962802	ACU 30-P	73	<b>716</b>	07964202	ACU 30-PO	82	<b>1078</b>
	Wall Mount	08745502	UHP 30-WJR	<b>976</b>	07990602	UHP 30-W	48	<b>790</b>	07962902	ACU 30-W	48	<b>601</b>	07964302	ACU 30-WO	52	<b>905</b>

# TPI Industrial Specialty Circulator Heads

## Features

- No cord-junction box provided for hard wiring
- Steel hub/spider aluminum paddle blades
- Coated steel guards
- Meets OSHA standards
- 1 year limited warranty
- Made in U.S.A. with domestic and foreign components

## Motor Specifications

- All 1 Speed (except 277V which is 2 Speed)
- Totally enclosed, permanently lubricated
- Ball bearing

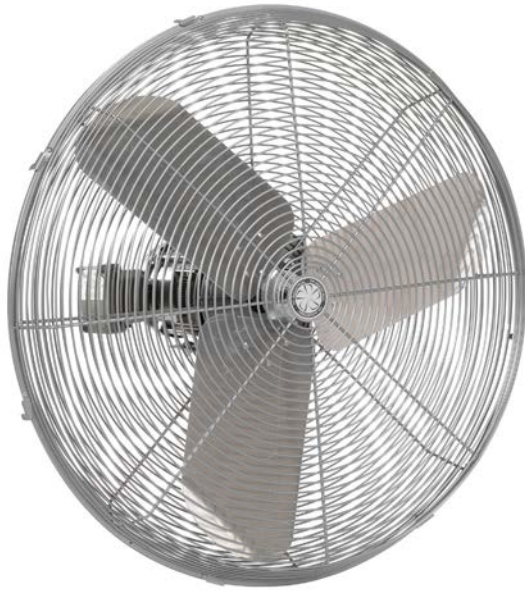

**ACH-EX SERIES**



**Intertek**

\*Listing applies to 277V models only



**IHP-H-277 SERIES**



**IHP-H-WD SERIES**

**WARNING:** This product can expose you to chemicals including nickel which is known to the State of California to cause cancer, and chromium, which is known to the State of California to cause birth defects and/or reproductive harm. For more information go to [www.P65Warnings.ca.gov](http://www.P65Warnings.ca.gov).

## Standard Models

GENERAL DESCRIPTION	MFG MODEL NUMBER	MFG CATALOG NUMBER	SIZE	CFM*		VELOCITY PROFILE CFM / Area Sq Ft	MOTOR			AMPS (HIGH)					WT. (LBS)	LIST
				HIGH	LOW		HP	RPM	VOLTS	120v 1 ph	240v 1 ph	277v 1 ph	240v 3 ph	480v 3 ph		
Hazardous Location Class I Group D Class II Group F & G Unassembled Head	ACH 24-EX1	08551902	24"	4300		6000 / 240	1/4	1725	120 or 240 1-phase	5	2.6	----	----	----	66	<b>1673</b>
	ACH 30-EX1	08552002	30"	5400		7200 / 250				5	2.6	----	----	----	69	<b>1814</b>
	ACH 24-EX3	08552102	24"	4300		6000 / 240			240 or 480 3-phase	----	----	----	1.4	0.7	66	<b>1784</b>
	ACH 30-EX3	08552202	30"	5400		7200 / 250				----	----	----	1.4	0.7	69	<b>1952</b>
240V / 480V 3-Phase Unassembled Head	ACH 24-TE3	08552302	24"	4300		6000 / 240	1/4	1075	208- 230/460 3-phase	----	----	----	2.2	2.2	45	<b>1154</b>
	ACH 30-TE3	08552402	30"	5400		7200 / 250				----	----	----	2.2	2.2	48	<b>1181</b>
277 Volt Assembled Head	IHP 24-H-277	08541302	24"	4300	3900	6000 / 240	1/3	1125	277 1-phase	----	----	1	----	----	40	<b>811</b>
	IHP 30-H-277	08542202	30"	5400	4700	7200 / 250				----	----	1	----	----	44	<b>863</b>
Wash down rated 120V / 240V 1-Phase Assembled Head	IHP 20-H-WD	08721902	20"	3200		5200 / 220	1/3	1725	120 or 240 1-phase	4.5	2.2	----	----	----	46	<b>1541</b>
	IHP 24-H-WD	08541802	24"	4300		6000 / 240				4.5	2.2	----	----	----	48	<b>1599</b>
	IHP 30-H-WD	08541902	30"	5400		7200 / 250				4.5	2.2	----	----	----	52	<b>1652</b>

\*Measured 2 feet from face of fan

**Note: Wash down rated fan heads have heavy zinc coated guards - Use FDA white coated mounts shown on page 7 for food service applications**

# TPI Industrial Circulator Components

## Standard Models

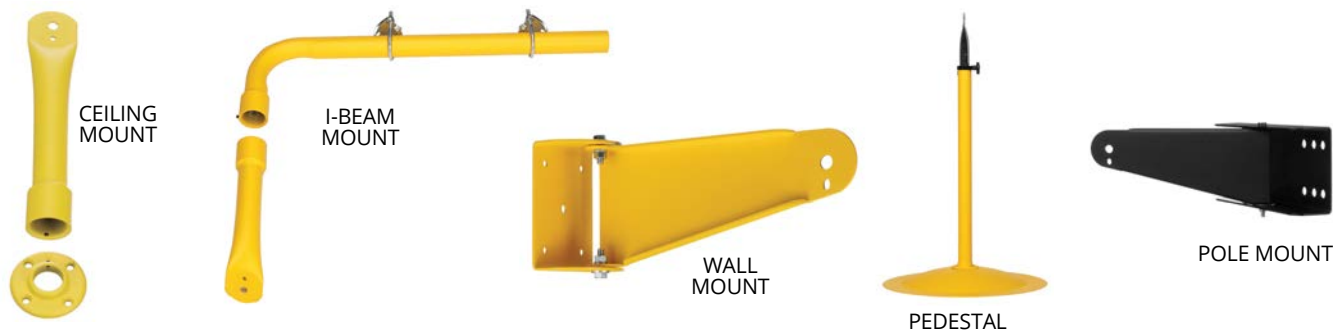
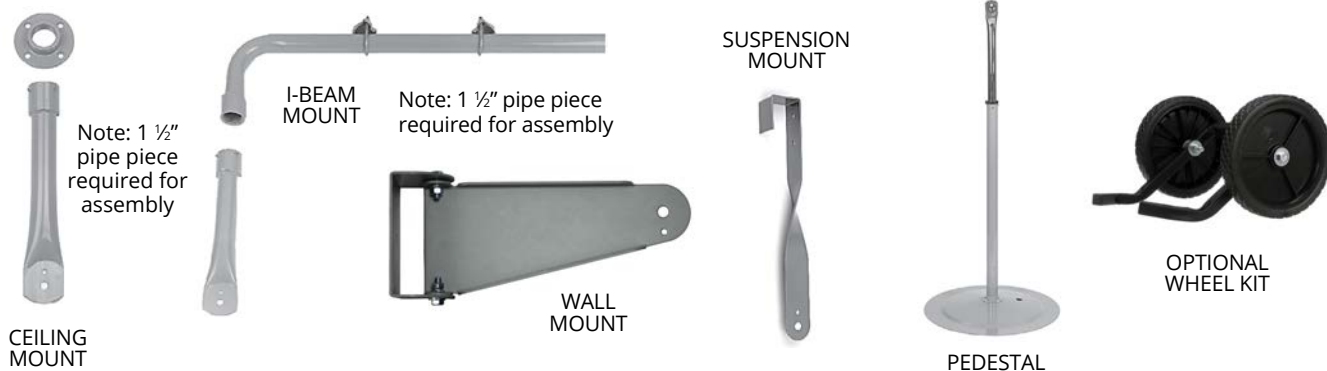

## Product Specifications

- Pedestal pole adjusts the center of fan from 48" to 67" and bolts to 27" diameter steel dome base with 5 bolts
- I-beam mount & ceiling mount require 1 1/2" or longer pipe nipple for assembly (not supplied)
- Pole mount attaches to 4", 6", or 8" with U-bolts (not supplied)
- Wheel kit and pole mount have an all black textured powder coated finish

## Mounts

TYPE	MFG CATALOG NUMBER	MFG MODEL NUMBER	LIST
YELLOW MOUNTS			
PEDESTAL POLE & BASE	07960902	HDM-P	315
WALL MOUNT	07961002	HDM-W	126
I-BEAM MOUNT	07961102	HDM-I	240
CEILING MOUNT	07961202	HDM-C	137
GRAY MOUNTS			
PEDESTAL POLE & BASE	07961802	ACM-P	298
WALL MOUNT	07961902	ACM-W	115
I-BEAM MOUNT	07962002	ACM-I	225
CEILING MOUNT	07962102	ACM-C	149
SUSPENSION MOUNT	07962202	ACM-S	102
POLE MOUNT	08681802	ACM-PM	164
WHEEL KIT	08681302	ACM-WK	139
FDA WHITE MOUNTS FOR USE WITH WASHDOWN FAN HEADS IN FOOD SERVICE APPLICATIONS			
PEDESTAL POLE & BASE	08682502	WACM-P	293
WALL MOUNT	08682602	WACM-W	115

## What to know when ordering TPI Air Circulators:

### 1) What is the operating voltage and phase?

- a. 120V (most common)
- b. 120V or 240V
- c. 277V
- d. 240 or 480V (offered in 3-phase)

### 2) How will you be mounting or operating this unit?

- a. Wall / Vertical Surface (Most Common)
- b. Floor - Pedestal Mount
- c. Pole Mount
- d. Ceiling
- e. Suspension Mount
- f. I-Beam Mount

### 3. What environment will this unit be operating in?

- a. Industrial - see TPI Series: HDH, IHP or ACH's
  - i. Dirty, dusty job sites or harsh industrial environment
  - ii. Wet, high moisture, or wash down rated environment
  - iii. Hazardous Location - Class I Group D, Class II Groups F & G
- b. Commercial - see TPI Series; CACU's
  - i. Clean areas or non-dusty environment

### 4. Will you need the fan head to rotate?

- a. Oscillating
- b. Non-Oscillating Fan Heads

### 5. Do you want to order assembled fan heads?

- a. Assembled Fan Head
- b. Unassembled Fan Head (ACU, UHP & CACU Series)

### 6. Do you have a color preference?

- a. Safety Yellow - HDH Series
- b. Industrial Textured Gray Finish (Most popular)
- c. Black Semi-Gloss Powder Coated Finish (CACU-Series)

## Air Circulators - Motor Comparisons

### Commercial Motors - Open Vent Motors

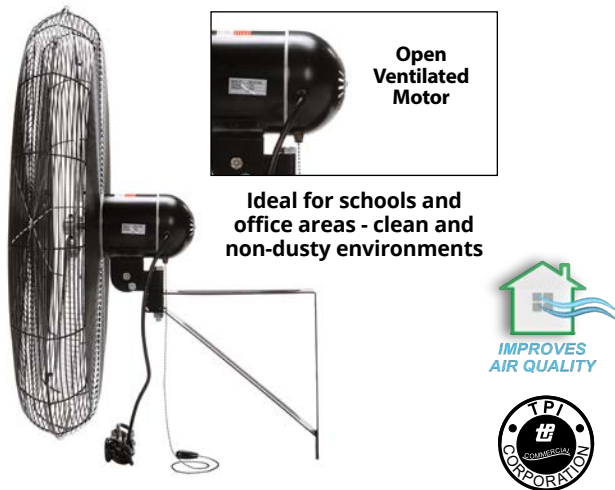

- Offered in 1/4 HP & 1/3 HP
- Good output
- Open ventilated (air goes through the motor)
- Oscillating and Non-Oscillating
- Unassembled fan heads only
- 1-year limited warranty
- Ideal for Commercial Applications
  - offered in 120V models

### Industrial Motors -Totally Enclosed Motors (TEAO)



- Offered in 1/4 HP, 1/3 HP & 1/2 HP
- Higher quality and high CFP output
- Totally Enclosed Air Over (TEAO)
- Oscillating and Non-Oscillating
- Fully assembled fan heads
- No tools required to open grill assembly (retainer clips)
- 3-year warranty on 1/3 HP motors (5-year on 1/2 HP)
- Ideal for Commercial Applications
  - offered in 120, 240, 277 & 480V models
  - washdown and Hazardous Location Rated models

### Commercial Fan Applications

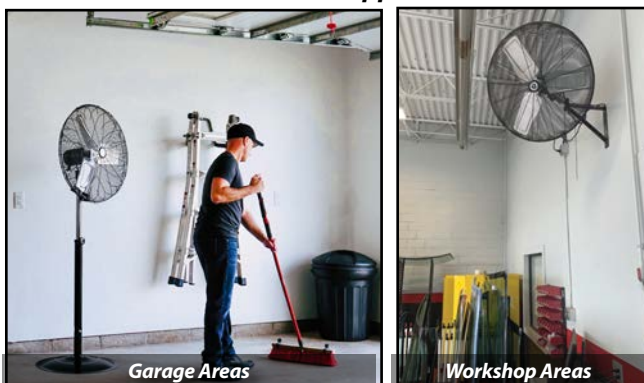

### Industrial Fan Applications





# TPI Commercial Circulators



These circulators should be used in clean and dry commercial applications - such as schools, shops, offices or warehouses.

## Commercial Circulator

**Motor, blades, guards, and mount are packed and shipped in a single UPS-able carton.**

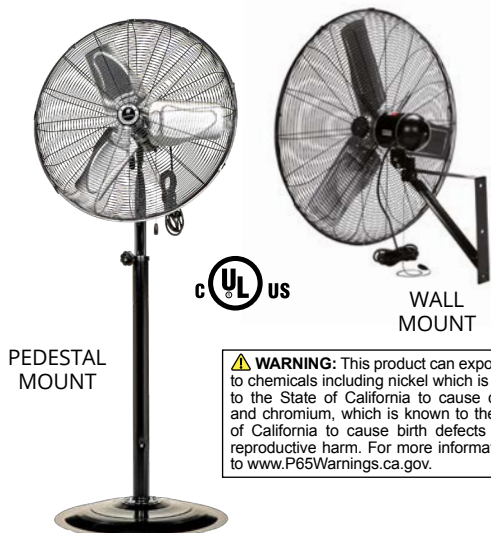

### Features

- Black semi-gloss powder coated finish
- Pull chain switch
- SJT type 3 conductor, 9' long cord
- Coated steel guards with retaining clips
- Steel hub/spider aluminum paddle blades
- Pole adjusts center of fan from 43" to 60"
- Meets OSHA standards / 1-Year limited warranty
- Imported to TPI specifications

### Motor Specifications

- 1-Phase
- 1/4 HP, 1/3 HP on HD Models
- Ball bearing
- Open ventilated
- 120V
- 3-speed
- Permanently lubricated
- Permanent split capacitor

**WARNING:** This product can expose you to chemicals including nickel which is known to the State of California to cause cancer, and chromium, which is known to the State of California to cause birth defects and/or reproductive harm. For more information go to [www.P65Warnings.ca.gov](http://www.P65Warnings.ca.gov).

## Standard Non-Oscillating Models

MFG CATALOG NUMBER	MFG MODEL NUMBER	SIZE	HP	TYPE	MOUNT TYPE	CFM*			VELOCITY PROFILE CFM / Area Sq Ft	AMPS (HIGH)	WT. (LBS)	LIST
						HIGH	MED	LOW				
08778002	CACU 20-P	20"	1/12	Non - Oscillating	Pedestal Mount	1780	1600	1420	3300 / 125	1.38	52	<b>402</b>
08778102	CACU 20-W				Wall Mount						48	<b>362</b>
08706202	CACU 24-P	24"	1/8		Pedestal Mount	3400	3100	2800	5400 / 220	1.75	63	<b>592</b>
08706402	CACU 24-W				Wall Mount						43	<b>506</b>
08697402	CACU 30-P	30"	1/6		Pedestal Mount	4200	3800	3500	6700 / 240	1.93	66	<b>651</b>
08706302	CACU 30-W				Wall Mount						46	<b>522</b>
08761702	CACU 30-P-HD	30"	1/4		Pedestal Mount	5000	4600	4200	7000 / 250	3.60	56	<b>759</b>

\*Measured 2 feet from face of fan

Note: Stocked models may differ in appearance from photograph

## TPI Commercial Oscillating Fans

### Standard Oscillating Models



WALL MOUNT

MFG CATALOG NUMBER	MFG MODEL NUMBER	SIZE	HP	TYPE	MOUNT TYPE	CFM*			VELOCITY PROFILE CFM / Area Sq Ft	AMPS			WT. (LBS)	LIST
						HIGH	MED	LOW		HIGH	MED	LOW		
08748902	CACU 24-PO	24"	1/8	Oscillating	Pedestal Mount	3200	3000	2800	5100 / 230	1.75	1.26	1.15	68	<b>697</b>
08749102	CACU 24-WO				Wall Mount								48	<b>597</b>
08749002	CACU 30-PO	30"	1/6		Pedestal Mount	4200	3800	3500	6700 / 250	1.93	1.68	1.53	70	<b>732</b>
08749202	CACU 30-WO				Wall Mount								51	<b>648</b>
08761802	CACU 30-PO-HD	30"	1/4		Pedestal Mount	5000	4600	4200	7000 / 250	3.60	3.02	2.94	64	<b>938</b>

**Notes:**

\*Measured 2 feet from face of fan

Stocked models may differ in appearance from photograph - sizes are nominal

Units imported to TPI specifications.



# 36" & 42" TPI Commercial Belt Drive Portable Blowers



**⚠️ WARNING:** This product can expose you to chemicals including nickel which is known to the State of California to cause cancer, and chromium, which is known to the State of California to cause birth defects and/or reproductive harm. For more information go to [www.P65Warnings.ca.gov](http://www.P65Warnings.ca.gov).



### Features

- Rotary switch
- SJT type cord - 3 conductor - 8' long
- Aluminum 4-paddle blade
- Spiral wire front and rear guards
- Black powder coated 20 gauge steel housing
- Stationary non-swivel housing
- 5" rubber wheels
- Meets OSHA standards
- 1-year limited warranty
- Imported to TPI specifications

### Motor Specification

- 2-Speed
- 120V
- Ball bearing
- 1-Phase
- ODP type
- Permanently lubricated

### Standard Models

MFG CATALOG NUMBER	MFG MODEL NUMBER	MOTOR HP	CFM*		VELOCITY PROFILE	MAX AMPS	WT. (LBS)	LIST
			HIGH	LOW	CFM / Area Sq Ft			
08734702	CPB 36-B	1/3	5,400	4,600	8600 / 300	4.20	82	<b>922</b>
08706602	CPB 42-B	1/3	7,600	6,700	12000 / 320	5.56	93	<b>1102</b>

\*Measured 2 feet from face of fan

Note: Photograph is a representation of stocked models. Actual model may vary in appearance

# 24", 30", & 36" TPI Commercial Direct Drive Portable Blowers



CPB 36-D



CPBS 30-D

**⚠️ WARNING:** This product can expose you to chemicals including nickel which is known to the State of California to cause cancer, and chromium, which is known to the State of California to cause birth defects and/or reproductive harm. For more information go to [www.P65Warnings.ca.gov](http://www.P65Warnings.ca.gov).

### Features

- Rotary or rocker switch
- SJT type cord - 3 conductor
- Spiral wire front and rear guards
- Black powder coated 20-gauge steel housing
- 5" rubber wheels
- Meets OSHA standards
- 1 Year limited warranty
- Imported to TPI specifications

### Motor Specification

- 2-Speed
- 120 Volt
- Ball bearing
- 1-Phase
- Open ventilated
- Permanently lubricated

### Standard Models

MFG CATALOG NUMBER	MFG MODEL NUMBER	BASE TYPE	MOTOR HP	CFM*		VELOCITY PROFILE	MAX AMPS	CORD LENGTH	SWITCH	BLADES	WT. (LBS)	LIST
				HIGH	LOW	CFM / Area Sq Ft						
08753502	CPB 30-D	Floor	1/5	4,400	3,800	6700 / 250	2.73	6'	Rocker	Aluminum	52	<b>564</b>
08710302	CPBS 30-D	Swivel	1/5	4,400	3,800	6700 / 250	2.73	6'	Rocker	Aluminum	60	<b>608</b>
08722602	CPB 36-D	Floor	1/3	5,400	4,600	8500 / 300	3.97	10'	Rotary	Steel	70	<b>737</b>
08770102	CPBS 24-DHV	Swivel	1/6	3,400	2,900	5400 / 240	2.35	9'	Rotary	Aluminum	38	<b>346</b>

\*Measured 2 feet from face of fan

Note: Photograph is a representation of stocked models. Actual model may vary slightly in appearance

# 30", 36", & 42" TPI Industrial Direct Drive Portable Blowers



STANDARD MODEL



SWIVEL MODEL



**WARNING:** This product can expose you to chemicals including nickel which is known to the State of California to cause cancer, and chromium, which is known to the State of California to cause birth defects and/or reproductive harm. For more information go to [www.P65Warnings.ca.gov](http://www.P65Warnings.ca.gov).

## Features

- Comes in sizes 30", 36", & 42"
- Rocker switch
- SJT type 3 conductor, 12' long cord
- Aluminum, 3 paddle blade
- Spiral, wire front and rear guards
- Corrosion and dent proof high density polyethylene housing
- 36" & 42" swivel model rotates 130° in 12 1/2° increments and locks in place with a steel locking pin
- Meets OSHA standards
- 1 Year limited warranty
- Made in U.S.A.

## Motor Specifications

- 120V, 1-Phase
- 30"-1/4HP 42"-1/2HP
- Ball bearing
- Permanent split capacitor
- 2-speed on 30" & 36" model
- 1-speed on 42" model
- Permanently lubricated
- Totally enclosed

## Standard Models

MFG CATALOG NUMBER	MFG MODEL NUMBER	FAN		WHEEL SIZE	MOTOR HP	CFM* / RPM		VELOCITY PROFILE	AMPS (HIGH)	WT. (LBS.)	LIST
		SIZE	TYPE			HIGH	LOW	CFM / Area Sq Ft			
08211002	PBX 30-D	30"	STANDARD	8"	1/4	4400 / 1100	3800 / 950	7200 / 250	2.7	65	<b>1029</b>
08213602	PBXS 30-D	30"	SWIVEL	10"						70	<b>1377</b>
08211102	PBX 36-D	36"	STANDARD	8"	1/3	6500 / 1040	5400 / 950	11500 / 320	5.5	82	<b>1197</b>
08213702	PBXS 36-D	36"	SWIVEL	10"						110	<b>1676</b>
08211202	PBX 42-D	42"	STANDARD	10"	1/2	9,000 / 825	15000 / 340	7.9	102	<b>1413</b>	
08213802	PBXS 42-D	42"	SWIVEL	10"					128	<b>1820</b>	

\*Measured 2 feet from face of fan

**Note: Photograph is a representation of stocked models. Actual model may vary slightly in appearance**

# 48" TPI Industrial Direct Drive Portable Blowers



**WARNING:** This product can expose you to chemicals including nickel which is known to the State of California to cause cancer, and chromium, which is known to the State of California to cause birth defects and/or reproductive harm. For more information go to [www.P65Warnings.ca.gov](http://www.P65Warnings.ca.gov).

## Features

- Corrosion and dent proof high density polyethylene housing
- Rocker switch
- SJT type 3 conductor, 12' long cord
- Steel, 2 paddle blade
- Spiral, wire front and rear guards
- 10" wheels
- Swivel model rotates 130° in 12 1/2° increments and locks in place with a steel locking pin
- Meets OSHA standards
- 1-Year limited warranty
- Made in U.S.A.

## Motor Specifications

- 1-Phase
- 3/4 HP
- Ball bearing
- Permanent split capacitor
- 120V
- 1-Speed
- Permanently lubricated
- Totally enclosed

## Features

MFG CATALOG NUMBER	MFG MODEL NUMBER	SIZE	FAN TYPE	MOTOR HP	CFM* / RPM	VELOCITY PROFILE	AMPS (HIGH)	DIMENSIONS			WT. (LBS)	LIST
						CFM / Area Sq Ft		"H"	"D"	"W"		
07997802	PB 48-D-OP	48"	STANDARD	3/4	11,800 / 825	14000 / 360	10.3	58.5	29	55.5	117	<b>2379</b>
07998002	PBS 48-D-OP	48"	SWIVEL	3/4	11,800 / 825	14000 / 360	10.3	----	----	----	142	<b>2716</b>

\*Measured 2 feet from face of fan

**Note: Photograph is a representation of stocked models. Actual model may vary slightly in appearance**

# 36", 42", & 48" TPI Industrial Belt Drive Portable Blowers



STANDARD MODEL



**WARNING:** This product can expose you to chemicals including nickel which is known to the State of California to cause cancer, and chromium, which is known to the State of California to cause birth defects and/or reproductive harm. For more information go to [www.P65Warnings.ca.gov](http://www.P65Warnings.ca.gov).



SWIVEL MODEL



CORD WRAP INCLUDED WITH STANDARD MODEL

## Features

- Comes in sizes 36", 42", and 48"
- Rocker switch on 120V, Single Phase models
- SJT type 3 conductor, 12' long cord on 120V, single phase models/ no cord on dual voltage models
- 4 paddle blade: 36" PB / PBS & HL have aluminum blade; 42" & 48" PB / PBS have steel blade
- Spiral, wire front and rear guards
- Corrosion and dent-proof high density polyethylene housing
- 8" wheels (36" model), 10" wheels (42" & 48" models)
- Swivel model rotates 130° in 12 1/2° increments and locks in place with a steel locking pin
- External junction boxes on dual voltage models allow units to be wired for either voltage without removing guards
- Hazardous location models have explosion proof motors, metal housings, and external junction boxes rated for Class I, Group D and Class II, Groups E, F, & G
- Meets OSHA standards
- 1 year limited warranty
- Made in U.S.A.

## Motor Specifications

- Single speed
- Permanently lubricated
- Ball bearing

## Standard Models

MOTOR LISTING	SIZE	MOTOR				CFM**	VELOCITY PROFILE	STANDARD MODEL				SWIVEL MODEL			
		TYPE	HP	RPM	AMPS		CFM / Area Sq Ft	MFG CATALOG NUMBER	MFG MODEL NUMBER	WT. (LBS)	LIST	MFG CATALOG NUMBER	MFG MODEL NUMBER	WT. (LBS)	LIST
	36"	120 V 1 PH ODP	1/2	500	8.0	6,900	14000 / 360	08211402	PBX 36-B	120	<b>1461</b>	08213302	PBXS 36-B	145	<b>1916</b>
	42"		3/4	430	11.0	10,600	17500 / 420	08211502	PBX 42-B	135	<b>1796</b>	08213402	PBXS 42-B	160	<b>2179</b>
	48"		1	390	15.0	14,400	23500 / 550	08211602	PBX 48-B	155	<b>1892</b>	08213502	PBXS 48-B	180	<b>2299</b>
	36"	240/480 V 3 PH ODP	1/2	500	2.3 / 1.1	6,900	14000 / 360	08508602	PB 36-B-3	127	<b>2349</b>	08509202	PBS 36-B-3	152	<b>2769</b>
	42"		3/4	430	3.3 / 1.5	10,600	17500 / 420	08508702	PB 42-B-3	143	<b>2635</b>	08509302	PBS 42-B-3	168	<b>3285</b>
	48"		1	390	3.8 / 1.9	14,400	23500 / 550	08508802	PB 48-B-3	164	<b>2998</b>	08509402	PBS 48-B-3	189	<b>3457</b>
----	36"	120/240 V 1 PH EXP	1/2	500	7.8 / 3.9	6,900	14000 / 360	08508902	PB 36-B-HL*	135	<b>3541</b>	08509502	PBS 36-B-HL	160	<b>3908</b>
	42"		3/4	430	10.8 / 5.4	10,600	17500 / 420	08509002	PB 42-B-HL*	150	<b>3726</b>	08509602	PBS 42-B-HL	175	<b>4454</b>
	48"		1	390	13.2 / 6.6	14,400	23500 / 550	08509102	PB 48-B-HL*	173	<b>4371</b>	08509702	PBS 48-B-HL	198	<b>4821</b>

Note: Products listed in this section are custom built and subject to 100% cancellation/restocking charges.  
 Note: Photograph is a representation of stocked models. Actual model may vary slightly in appearance.

\*Models have no listing.

# TPI Industrial Direct Drive Suspension Blowers

12



**WARNING:** This product can expose you to chemicals including nickel which is known to the State of California to cause cancer, and chromium, which is known to the State of California to cause birth defects and/or reproductive harm. For more information go to [www.P65Warnings.ca.gov](http://www.P65Warnings.ca.gov).

## Features

- On-off rocker switch
- SJT type 3 conductor, 12' long cord
- Aluminum blade
- Powder coated spiral wire front and rear guards
- Corrosion and dent proof high density polyethylene housing
- Meets OSHA standards
- 1-year limited warranty
- Mounting chain not included
- Made in U.S.A.

## Motor Specifications

- 120V, 1-Phase
- Ball bearing
- Permanent split capacitor
- 2-Speed on 30" & 36" model
- 1-Speed on 42" model
- Permanently lubricated

## Standard Models

SIZE	MOTOR HP	MFG CATALOG NUMBER	MFG MODEL NUMBER	CFM*		VELOCITY PROFILE	RPM HIGH	AMPS HIGH	WT. (LBS)	LIST
				HIGH	LOW	CFM / Area Sq Ft				
30"	1/4	08213002	SBX 30-D	4,400	3,800	7200 / 250	1050	2.7	58	<b>1029</b>
36"	1/3	08213102	SBX 36-D	6,500	5,400	11500 / 320	1050	5.6	70	<b>1138</b>
42"	1/2	08213202	SBX 42-D	9,000		15000 / 340	825	7.9	99	<b>1341</b>

\*Measured 2 feet from face of fan

# TPI Industrial Belt Drive Suspension Blowers



**WARNING:** This product can expose you to chemicals including nickel which is known to the State of California to cause cancer, and chromium, which is known to the State of California to cause birth defects and/or reproductive harm. For more information go to [www.P65Warnings.ca.gov](http://www.P65Warnings.ca.gov).

## Features

- On-off rocker switch on 120V, 1-Phase models
- SJT type 3 conductor, 12' long cord on 120V, 1-phase models
- No cord on dual voltage models
- Aluminum blade: SB 36-B, SB 36-B-HL,
- SB 42-B-HL, SB 48-B-HL
- Steel blade: SB 42-B, SB 48-B
- Corrosion and dent proof high density polyethylene housing
- Powder coated spiral wire front and rear guards
- Meets OSHA standards
- 1 year limited warranty
- Mounting chain not included
- Made in U.S.A.

## Motor Specifications

- 120V, 1-Phase
- Ball bearing
- Permanent split capacitor
- 2-Speed on 30" & 36" model
- 1-Speed on 42" model
- Permanently lubricated

External junction boxes on dual voltage models allow units to be wired for either voltage without removing guards.

Hazardous Location models have explosion proof motors and external junction boxes rated for Class I, Group D, & Class II, Groups E, F & G. (Metal housing and no switch)

## Standard Models

MFG CATALOG NUMBER	MFG MODEL NUMBER	SIZE	MOTOR		CFM**	VELOCITY PROFILE	RPM	AMPS	WT. (LBS)	LIST
			TYPE	HP		CFM / Area Sq Ft				
08212702	SBX 36-B	36"	115 V, 1 PH, ODP	1/2	6,900	14000 / 360	500	8	120	<b>1389</b>
08212802	SBX 42-B	42"		3/4	10,600	17500 / 420	430	11	135	<b>1628</b>
08212902	SBX 48-B	48"		1	14,400	23500 / 550	390	15	155	<b>1700</b>
08509802	SB 36-B-3	36"	230 / 460 V, 3 PH, ODP	1/2	6,900	14000 / 360	500	2.3 / 1.1	127	<b>2240</b>
08509902	SB 42-B-3	42"		3/4	10,600	17500 / 420	430	3.3 / 1.5	143	<b>2712</b>
08510002	SB 48-B-3	48"		1	14,400	23500 / 550	390	3.8 / 1.9	164	<b>2851</b>
08510102	SB 36-B-HL*	36"	115 / 230 V, 1 PH, EXP	1/2	6,900	14000 / 360	500	7.8 / 3.9	135	<b>3541</b>
08510202	SB 42-B-HL*	42"		3/4	10,600	17500 / 420	430	10.8 / 5.4	150	<b>4026</b>
08510302	SB 48-B-HL*	48"		1	14,400	23500 / 550	390	13.2 / 6.6	173	<b>4371</b>

Note: Products listed in this section are custom built and subject to 100% cancellation/restocking charges.

\*Models have no listing.  
\*\*Measured 2 feet from face of fan



FLOOR MODEL



YOKE MOUNTED MODEL



MBM-W  
(Optional Wall/  
Ceiling Mount)

**WARNING:** This product can expose you to chemicals including nickel which is known to the State of California to cause cancer, and chromium, which is known to the State of California to cause birth defects and/or reproductive harm. For more information go to [www.P65Warnings.ca.gov](http://www.P65Warnings.ca.gov).

### Features

- Floor model or yoke mount models available
- Floor models have rotary switch
- Yoke mounted models have pull chain switch
- SJT type 3 conductor, 10' long cord
- Aluminum blade
- Spiral, wire front and rear guards
- For use in dirty or dusty environments
- Corrosion and dent proof high density polyethylene housing
- Bolt to any surface, or use with optional wall/ceiling mount.
- Meets OSHA standards
- 1 year limited warranty
- Made in U.S.A. with domestic and foreign components

### Motor Specifications

- 1-Phase
- 1/4 HP
- Ball bearing
- Totally enclosed
- 120V
- 2-Speed
- Permanently lubricated
- Permanent split capacitor

### Standard Models

MFG CATALOG NUMBER	MFG MODEL NUMBER	FAN		CFM* / RPM		VELOCITY PROFILE CFM / Area Sq Ft	DIMENSIONS			AMPS (High)	WT. (LBS)	LIST
		TYPE	SIZE	HIGH	LOW		"H"	"W"	"D"			
08216302	MBX-24-DF	FLOOR STYLE	24"	3300 / 1140	2900 / 1070	5200 / 240	29 1/2"	28 1/2"	14 1/4"	1.8	52	<b>1012</b>
08216502	MBX-24-DY	YOKE STYLE					29"	28 1/2"	14 1/4"		52	<b>1012</b>
08216402	MBX-30-DF	FLOOR STYLE	30"	4400 / 1040	3900 / 730	7000 / 250	38 1/2"	37 1/2"	14 1/2"	2.7	58	<b>1118</b>
08216602	MBX-30-DY	YOKE STYLE					38"	37 1/2"	14 1/2"		58	<b>1118</b>
07989002	MBM-W	OPTIONAL WALL/CEILING MOUNT FOR YOKE STYLE MINI-BLOWER									4	<b>205</b>

\*Measured 2 feet from face of fan

## TPI Industrial Heavy Duty Square Belt Drive Portable Blowers



4" CASTERS



**WARNING:** This product can expose you to chemicals including nickel which is known to the State of California to cause cancer, and chromium, which is known to the State of California to cause birth defects and/or reproductive harm. For more information go to [www.P65Warnings.ca.gov](http://www.P65Warnings.ca.gov).

### Features

- On-off rocker switch
- SJT type 3 conductor, 12' long cord
- Steel blade
- Permanently lubricated bearings on blade drive shaft
- Powder coated front and rear guards
- Powder coated 20 gauge venturi
- 18 gauge galvanized steel housing
- Meets OSHA standards / 1 year limited warranty
- Made in U.S.A.

### Motor Specifications

- 1-Phase
- Ball bearing
- Drip proof motor
- 120V
- 1-Speed
- Permanently lubricated
- 1/2" Shaft

### Standard Models

SIZE	MFG CATALOG NUMBER	MFG MODEL NUMBER	MOTOR			CFM*	VELOCITY PROFILE CFM / Area Sq Ft	DIMENSIONS			WT. (LBS)	LIST
			HP	RPM	AMPS			"H"	"W"	"D"		
36"	08683602	PCBT 36-B	1/2	1725	8.0	6,900	14,000 / 360	48 1/4"	40.38"	22 1/2"	120	<b>2582</b>
42"	08683702	PCBT 42-B	3/4		11.0	10,600	17,500 / 420	56 1/2"	48.38"	22 1/2"	140	<b>3354</b>
48"	08683802	PCBT 48-B	1		15.0	14,400	23,500 / 550	62 1/2"	54.38"	18 1/2"	185	<b>4079</b>

\*Measured 2 feet from face of fan



### Features

- ETL C/US listed for indoor spot cooling applications
- 20-gauge all steel construction housing with gray epoxy powder coated finish
- Heavy-duty yoke mounting bracket design with 2" square steel tubing frame
- Direct drive Totally Enclosed Air-Over (TEAO) motor generating up to 9,000-CFM's
- Single speed, ball bearing, with split capacitor, permanently lubricated, TEAO motor operates on 60HZ and 1725-RPMs, and requires hard-wired connection to the supplied electrical enclosure located on the motor housing
- Aluminum 3-paddle blade system with steel hub and cast aluminum spider connections
- Non-oscillating fan heads offered 18", 24" & 30" diameter sizes
- 2-year motor warranty

### Benefits

- Housing designed for all types of air circulating applications to provide directional – high velocity air flow.
- Built-in rotating design allows the supplied mounting bracket to pivot 120° (9) adjustment settings at 15° variations.
- Front & rear spiral wound grills are OSHA approved and have a black powder coated finish.
- All units are shipped fully assembled and ready for hard-wired connections
- TEAO motor has a Class B rating, with automatic thermal protection and ball bearing design for harsh environments; rated up to 115°F max. ambient temp. Single and three phase options available in 120, 277 & 480-Volt.

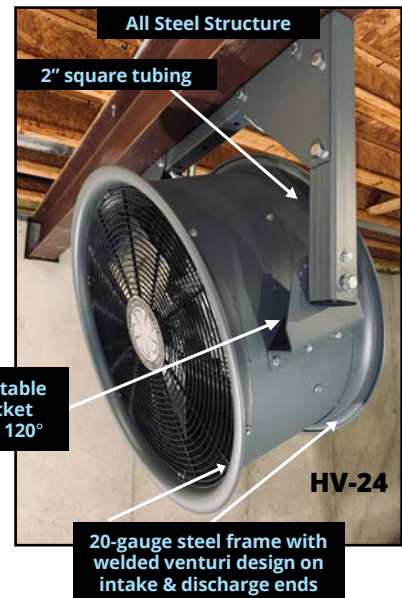

### Specifications

- 1-Speed
- 1 Phase, 120V, 208/240V, 277V or 480V
- 3-Phase, 480V
- Ball bearing
- Totally enclosed, air over
- Permanent split capacitor/lubricate
- 1/2" Motor Shaft

### Applications

Units are ideal for warehouse, material handling, and high-shelf areas for directing high volumes of air flow down aisles, loading dock areas, conveyor systems, processing centers, workstations, jobsite, and all types of industrial operations for rugged environments.

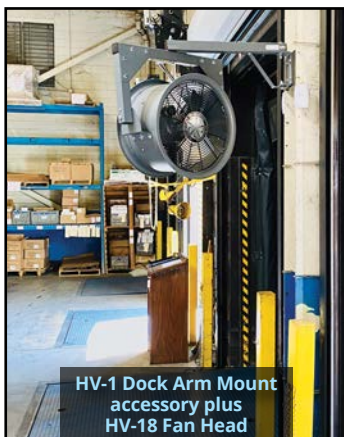

**HV-30**



**HV-1**

**HV-3 Wall/Column Mount Accessory plus HV-30 Fan Head**



## Standard Models

SIZE	MFG CATALOG NUMBER	MFG MODEL NUMBER	VOLTS	PH	AMPS (High)	HP	WATTS	RPM	CFM	VELOCITY PROFILE CFM/Area Sq. Ft.	BLADE DIA.	DIMENSIONS (in.)			WT. (lbs.)	LIST
												L	W	H		
18"	08195602	HV-18-120V	120	1	3.4	1/2	373	1725	3000	5000 / 175	16"	13.5	27.4	26	45	<b>1584</b>
	08195702	HV-18-208/240V	208/240	1	1.9	1/2	373	1725	3000	5000/175	16"	13.5	27.4	26	45	<b>1584</b>
	08195802	HV-18-277V	277	1	1.5	1/2	373	1725	3000	5000/175	16"	13.5	27.4	26	45	<b>1584</b>
	08195902	HV-18-480V	480	1	1.0	1/2	373	1725	3000	5000/175	16"	13.5	27.4	26	45	<b>1584</b>
	08197202	HV-18-480V-3	208-230/460	3	1.4 / 0.8	1/2	373	1725	3000	5000/175	16"	13.5	27.4	26	45	<b>1816</b>
24"	08196002	HV-24-120V	120	1	3.8	1/2	373	1725	3000	8500/275	16"	13.5	33.3	31.4	45	<b>1815</b>
	08196102	HV-24-208/240V	208/240	1	2.1	1/2	373	373	5290	8500/275	22"	13.5	33.3	31.4	58	<b>1815</b>
	08196202	HV-24-277V	277	1	1.7	1/2	373	373	5290	8500/275	22"	13.5	33.3	31.4	58	<b>1815</b>
	08196302	HV-24-480V	480	1	1.1	1/2	373	373	5290	8500/275	22"	13.5	33.3	31.4	58	<b>1815</b>
	08197302	HV-24-480V-3	208-230/460	3	1.5 / 0.8	1/2	373	373	5290	8500/275	22"	13.5	33.3	31.4	58	<b>2195</b>
30"	08196402	HV-30-120V	120	1	7.6	1	373	373	9000	14250/375	28"	16	38.9	39	58	<b>2623</b>
	08196502	HV-30-208/240V	208/240	1	4.3	1	746	1700	9000	14250/375	28"	16	38.9	39	85	<b>2623</b>
	08196602	HV-30-277V	277	1	3.2	1	746	1700	9000	14250/375	28"	16	38.9	39	85	<b>2623</b>
	08196702	HV-30-480V	480	1	1.6	1	746	1700	9000	14250/375	28"	16	38.9	39	85	<b>2623</b>
	08197402	HV-30-480V-3	208-230/460	3	3.4 / 1.6	1	746	1700	9000	14250/375	28"	16	38.9	39	85	<b>3218</b>

### Dimensions:

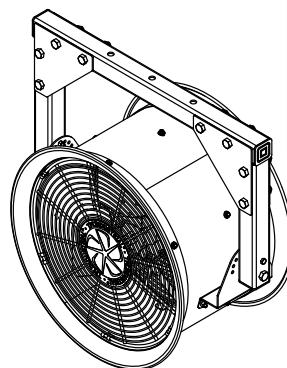
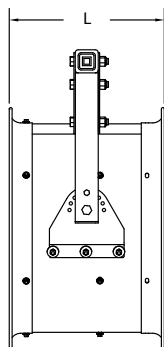
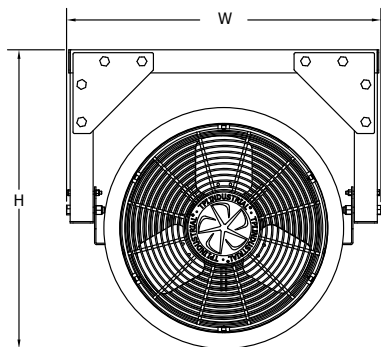

### Dock Swing Arm - 24" Reach



### Wall/Column Mount

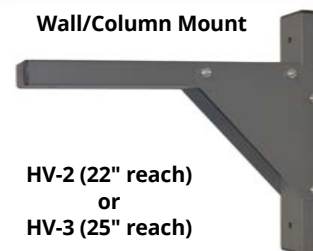

HV-2 (22" reach)  
or  
HV-3 (25" reach)

## Accessory Models

MFG CATALOG NUMBER	MFG MODEL NUMBER	TYPE	FITS MODEL SERIES	LIST
08197502	HV-1	Dock Arm, 24" Reach	HV-18	<b>231</b>
08197602	HV-2	Wall / Column Mount	HV-18 & HV-24	<b>331</b>
08197702	HV-3	Wall / Column Mount	ALL	<b>344</b>
08199002	HV-4-18	Low Stand	HV-18	<b>719</b>
08199102	HV-4-24		HV-24	<b>794</b>
08199202	HV-4-30		HV-30	<b>869</b>
08199302	HV-5-18	Medium Stand	HV-18	<b>1116</b>
08199402	HV-5-24		HV-24	<b>1229</b>
08199502	HV-5-30		HV-30	<b>1410</b>
08199602	HV-6-18	High Stand	HV-18	<b>1299</b>
08199702	HV-6-24		HV-24	<b>1477</b>
08199802	HV-6-30		HV-30	<b>1652</b>
08199902	HV-7-DC-1	Disconnect Switch	1-Phase	<b>760</b>
08200002	HV-7-DC-3		3-Phase	<b>793</b>
08209802	HV-8	Caster Kit (Qty.4)	ALL Heads/Stands	<b>246</b>



Image Shown Includes:

- HV-24 (Fan Head)
- HV-5-24 (Medium Stand)
- HV-8 (Caster Kit)

Note: All items must be ordered separately.

Note: Stands DO NOT include casters

Contact TPI customer Service for additional cost for mounting fan to the stand and wiring the disconnect prior to shipping.



# TPI Industrial Heavy Duty Direct Drive Blowers

**WARNING:** This product can expose you to chemicals including nickel which is known to the State of California to cause cancer, and chromium, which is known to the State of California to cause birth defects and/or reproductive harm. For more information go to [www.P65Warnings.ca.gov](http://www.P65Warnings.ca.gov).



LOW STAND



MEDIUM STAND



HIGH STAND

## Features

- Totally enclosed and explosion proof motors
- Explosion proof motors are Class 1, Div 1, Group D and Class 2, Div 1, Groups F & G
- Cast Aluminum props
- 14 gauge steel body and stand
- Acid resistant coating available
- Baked enamel coating
- 360° Swivel on high and medium stand units
- Meets federal OSHA requirements
- 1 year limited warranty

## NOTE:

- Single phase motors are field convertible 115V / 230V
- Three phase motors are field convertible 230V / 460V
- Motors are set to lower voltage at the factory unless a request is made at time of order to set to the higher voltage

## Standard Models

SIZE	MFG MODEL NUMBER	HP	RPM	CFM	DB's @ 10'	WT. (LBS)			LIST											
						STAND			TEC		EXP		TEC		EXP		TEC		EXP	
						LOW	MED	HIGH	1PH	3PH	1PH	3PH	1PH	3PH	1PH	3PH	1PH	3PH	1PH	3PH
MODEL NUMBER SUFFIXES									-L	-L-3	-L	-L-3	-M	-M-3	-M	-M-3	-H	-H-3	-H	-H-3
18"	MCD18-1/4	1/4	1725	3050	74	103	145	210	4213	4193	4848	4951	5193	5174	5816	5935	5664	5648	6307	12759
	MCD18-1/3	1/3	1725	3450	76	105	150	215	4355	4392	5182	5396	5332	5363	6159	6384	5809	5838	6644	12024
	MCD18-1	1	1725	4600	77	117	165	230	4913	4732	5828	5935	5903	5709	6797	6916	6376	6187	7282	7390
24"	MCD24-1/4	1/4	1725	5200	80	115	165	230	4310	4295	4932	5053	5414	5407	6035	6159	5801	5540	6420	6543
	MCD24-1/3	1/3	1140	5300	74	126	175	250	5001	5053	6358	6431	6104	6159	7460	7536	6491	6298	7847	7919
	MCD24-1/2	1/2	1725	6000	80	120	170	240	4671	4689	5642	5540	5774	5795	6741	6644	6159	5935	7129	7030
	MCD24-3/4	3/4	1140	6900	74	140	190	260	5962	5396	6760	6576	7068	6509	7867	7678	7450	6644	8251	8062
	MCD24-1	1	1725	7400	82	130	180	250	5068	4884	5969	6078	6170	5989	7073	7182	6556	6124	7460	7568
	MCD24-1 1/2	1.5	1725	8200	84	137	190	255	5353	5120	7911	6502	6457	6231	9015	7605	6842	6367	9400	7989
	MCD24-3	3	1725	10500	87	160	210	270	----	5589	----	7068	----	6689	----	8180	----	6834	----	8556
30"	MCD30-1/3	1/3	1140	6900	80	150	205	260	5487	5540	6842	6916	6697	6753	8055	8135	7182	7236	8530	8612
	MCD30-1/2	1/2	1725	8900	86	141	195	250	5162	5182	6132	6035	6384	6402	7352	7258	6863	6878	7827	7731
	MCD30-3/4	3/4	1140	10400	80	210	260	320	6315	5757	7104	6921	7523	6968	8323	8141	8001	7444	8797	8621
	MCD30-1	1	1140	11200	81	200	260	310	7568	6072	9026	7182	8790	7289	10244	8394	9264	7765	10719	8870
	MCD30-1 1/2	1.5	1725	12000	92	200	250	310	5828	5595	8387	6978	7039	6817	9608	8198	7514	7289	10082	8673
	MCD30-2	2	1140	14000	84	225	270	330	----	6491	----	8080	----	7712	----	9301	----	8188	----	9778
	MCD30-3	3	1725	16000	94	220	265	325	----	5942	----	7425	----	7165	----	8645	----	7644	----	9114
36"	MCD36-1	1	1140	13000	82	250	320	375	8547	7048	10003	8154	10048	8556	11508	9663	10363	8864	11815	9968
	MCD36-1 1/2	1.5	1725	14850	88	250	320	375	6760	6529	9318	7911	8262	8027	10818	9411	8574	8337	11134	9725
	MCD36-2	2	1140	17500	82	255	325	380	----	7211	----	8807	----	8719	----	10308	----	9026	----	10621
	MCD36-3	3	1725	18500	90	260	330	390	----	6888	----	8368	----	8387	----	9875	----	8699	----	10181
	MCD36-5	5	1725	23000	94	260	330	390	----	7005	----	8628	----	8501	----	10127	----	8807	----	10432
42"	MCD42-2	2	1140	19500	85	315	415	565	----	8279	----	9875	----	9875	----	11465	----	10506	----	12102
	MCD42-5	5	1725	27000	98	320	420	570	----	8062	----	9696	----	9663	----	11285	----	10298	----	11933
48"	MCD48-5	5	1140	32000	92	500	620	710	----	10936	----	13619	----	12695	----	15379	----	13814	----	16499
	MCD48-7 1/2	7.5	1140	37000	105	625	745	835	----	12695	----	17138	----	14457	----	18897	----	15576	----	20010
	MCD48-10	10	1140	41000	105	682	800	890	----	14857	----	18818	----	16616	----	20565	----	17732	----	21689
60"	MCD60-3	3	690	35000	87	690	855	965	----	23306	----	----	----	26625	----	----	----	27388	----	----
	MCD60-5	5	690	45000	87	730	895	1005	----	26212	----	----	----	29522	----	----	----	30295	----	----
	MCD60-7 1/2	7.5	870	47000	90	945	1110	1220	----	21966	----	----	----	25279	----	----	----	26043	----	----
	MCD60-10	10	870	57200	91	1035	1200	1310	----	27342	----	----	----	30655	----	----	----	31427	----	----
	MCD60-15	15	870	60750	92	1080	1245	1355	----	35762	----	----	----	39072	----	----	----	39844	----	----

## Manual Starter Switches

MFG MODEL NUMBER		H.P. RATING	LIST PRICE	
1 PH	3 PH		TEC	
SW-1/4	SW-1/4-3	1/4-1/3	750	1787
SW-1/2	SW-1/2-3	1/2-3/4	750	1787
SW-1	SW-1-3	1	750	1787
SW-1 1/2	SW-1 1/2-3	1.5	1756	1787
----	SW-2-3	2	----	1787
----	SW-3-3	3	----	1787
----	SW-5-3	5	----	1787
----	SW-7 1/2-3	7.5	----	1695

## Polyolifin Casters

MFG MODEL NUMBER	FAN SIZE	WHEEL SIZE	WT. (LBS)	LIST
CAS - 18	18" - 30"	4"	10	780
CAS - 48	36" - 48"	5"	14	1098

(FOR LOW & MEDIUM STAND)  
4 CASTERS - 2 LOCKING

Note: Products listed in this section are custom built and subject to 100% cancellation/restocking charges

# TPI Industrial Heavy Duty Permanent Mount Direct Drive Blowers



1-WAY SWIVEL

**WARNING:** This product can expose you to chemicals including nickel which is known to the State of California to cause cancer, and chromium, which is known to the State of California to cause birth defects and/or reproductive harm. For more information go to [www.P65Warnings.ca.gov](http://www.P65Warnings.ca.gov).

## Features

- Front and rear spiral guards
- Explosion proof motors are Class 1, Div 1, Group D and Class 2, Div 1, Groups F & G
- Cast aluminum props
- 14 gauge steel body and stand
- Meets federal OSHA requirements
- 1 year limited warranty

## NOTE:

- **Single Phase motors are field convertible 115V / 230V**
- **Three Phase motors are field convertible 230V / 460V**
- **Motors are set to lower voltage at the factory unless a request is made at time of order to set to the higher voltage**

## Standard Models

BLADE SIZE	MFG MODEL NUMBER	HP	RPM	CFM	DB'S @ 10'	WT. (LBS)		LIST PRICE							
						1-WAY SWIVEL	2-WAY SWIVEL	1-WAY SWIVEL				2-WAY SWIVEL			
								TEC		EXP		TEC		EXP	
						1PH	3PH	1PH	3PH	1PH	3PH	1PH	3PH		
MODEL NUMBER SUFFIXES								-T	-T-3	-T	-T-3	-S	-S-3	-S	-S-3
18"	MCD18-1/4	1/4	1725	3050	74	130	140	5589	5570	6211	6323	7011	6996	7651	7759
	MCD18-1/3	1/3	1725	3450	76	135	145	5730	5757	6557	6771	7157	7182	7989	8209
	MCD18-1	1	1725	4600	77	145	155	6285	6104	7193	7311	7721	7536	8628	8738
24"	MCD24-1/4	1/4	1725	5200	80	145	155	5757	5730	6376	6502	7258	7231	7867	7989
	MCD24-1/3	1/3	1140	5300	74	155	165	6446	6502	7804	7873	7936	7989	9294	9364
	MCD24-1/2	1/2	1725	6000	80	150	160	6116	6132	7085	6987	7605	7633	8574	8476
	MCD24-3/4	3/4	1140	6900	74	170	180	7407	6851	8209	8018	8899	8342	9696	9517
	MCD24-1	1	1725	7400	82	160	170	6509	6329	7419	7523	8001	7821	8907	9015
	MCD24-1 1/2	1.5	1725	8200	84	165	175	6788	6566	9354	7947	8286	8055	10844	9441
	MCD24-3	3	1725	10500	87	190	200	----	7030	----	8511	----	8521	----	10003
30"	MCD30-1/3	1/3	1140	6900	80	180	190	6987	7039	8342	8414	8639	8692	9984	10064
	MCD30-1/2	1/2	1725	8900	86	170	180	6662	6681	7644	7536	8318	8331	9285	9184
	MCD30-3/4	3/4	1140	10400	80	240	250	7814	7245	8612	8421	9456	8899	10255	10075
	MCD30-1	1	1140	11200	81	230	240	9069	7568	10532	8682	10719	9221	12174	10326
	MCD30-1 1/2	1.5	1725	12000	92	230	240	7328	7095	9886	8476	8978	8746	11535	10127
	MCD30-2	2	1140	14000	84	255	265	----	7989	----	9579	----	9644	----	11229
	MCD30-3	3	1725	16000	94	250	260	----	7444	----	8933	----	9084	----	10576
36"	MCD36-1	1	1140	13000	82	295	305	10415	8907	11870	10010	12460	10953	13916	12064
	MCD36-1 1/2	1.5	1725	14850	88	295	305	8612	8387	11181	9767	10734	10432	13222	11815
	MCD36-2	2	1140	17500	82	300	310	----	9069	----	10665	----	11126	----	12715
	MCD36-3	3	1725	18500	90	315	325	----	8746	----	10229	----	10790	----	12273
	MCD36-5	5	1725	23000	94	305	315	----	8851	----	10486	----	10910	----	12533

## Exhaust Ventilation Guide

Minute air change chart for Commercial and Industrial Applications

Place	Typical	Range
Assembly	(6)	2-10
Auditoriums	(6)	1-20
Bakeries	(2)	1-3
Banks	(6)	3-10
Bars	(4)	2-5
Barns	(15)	10-20
Boiler Rooms	(2)	1-3
Bowling Alley	(3)	1-5
Cafeteria	(4)	3-5
Churches	(6)	2-10
Classrooms	(6)	4-8
Compressor Rooms	(2)	1-3
Dance Halls	(6)	2-10
Dairies	(4)	2-5
Dormitories	(6)	4-8
Dry Cleaning Plant	(3)	1-5

CFM Required for Ventilation =

Place	Typical	Range
Engine Rooms	(3)	1-5
Factories	(7)	4-10
Foundries	(5)	2-8
Garages	(7)	4-10
Generating Plants	(4)	2-5
Glass Plants	(2)	1-3
Gymnasiums	(6)	2-10
Hallways	(8)	4-12
Kitchens (Comm.)	(3)	1-5
Laboratories	(3)	1-5
Libraries	(4)	2-5
Laundries	(2)	1-3
Locker Rooms	(6)	2-10
Machine Shops	(4)	2-5
Markets	(6)	2-10

Building Cubic Feet  
Minutes Per Air Change

Place	Typical	Range
Mills	(4)	2-5
Packing Houses	(4)	3-5
Plants	(7)	4-10
Plating Plants	(4)	2-5
Print Shops	(7)	4-10
Restaurants	(6)	2-10
Rest Rooms	(7)	4-10
Schools	(7)	4-10
Stores	(7)	4-10
Theaters	(6)	4-8
Transformer Rooms	(3)	1-5
Turbine Rooms	(4)	2-5
Waiting Rooms	(12)	10-15
Warehouses	(7)	4-10
Welding Rooms	(3)	1-4

Note: Products listed in this section are custom built and subject to 100% cancellation/restocking charges

# Industrial Workstation Floor Fans



## Features

- Steel construction with a silver & black powder coated finish
- Direct drive totally enclosed air-over (TEAO) motor generating up to 6000-CFM's (F24-TE-HV)
- Three-speed, 120V, 1/8, 1/4, or 1/12-HP, sleeve bearing, permanently lubricated, TEAO motor operates at 60HZ and 1660-RPMs
- Rotary switch located on the back grill
- 10' long SJT-type grounded 3-conductor cordset with molded plug
- Aluminum 3-paddle blade system with steel hub and cast aluminum spider connections
- 1-year manufacturer's warranty

**WARNING:** This product can expose you to chemicals including nickel which is known to the State of California to cause cancer, and chromium, which is known to the State of California to cause birth defects and/or reproductive harm. For more information go to [www.P65Warnings.ca.gov](http://www.P65Warnings.ca.gov).



## Motor Specifications

- Sleeve bearing
- Totally enclosed
- 1-phase, 120V
- 3-speed
- Permanently lubricated
- Frame size: 42
- 3/16" shaft

SIZE	MFG CATALOG NUMBER	MFG MODEL NUMBER	FAN TYPE	MOTOR HP	CFM** / RPM			VELOCITY PROFILE CFM / Area Sq Ft	DIMENSIONS			MAX AMPS	WT. (LBS)	LIST
					HIGH	MED	LOW		"H"	"W"	"D"			
12"	07986102	F-12-TE	FLOOR MODEL	1/12	900 / 1590	800 / 1380	700 / 1080	1400 / 50	15 1/4"	14 1/2"	9 1/2"	1.1	13	234
18"	07972902	F-18-TE		1/8	1800 / 1660	1500 / 1550	1300 / 1370	2900 / 125	20 1/2"	20 1/2"	10 1/2"	2.2	20	293
24"	08528502	F-24-TE		1/8	2100 / 1634	1900 / 1484	1600 / 1200	3500 / 150	26"	26"	10 1/2"	2.4	23	353
24"	08775402	F-24-TE-HV		1/4	3800 / 1100	3600 / 950	3400 / 800	6000 / 240	26"	26"	10 1/2"	2.7	25	402
18"	07973002	F-18H-TE*	HIGH STAND	1/8	1800 / 1660	1500 / 1550	1300 / 1370	2900 / 125	53"	25"	27"	2.2	27	443
24"	08540602	F-24H-TE*		1/8	2100 / 1634	1900 / 1484	1600 / 1200	3500 / 150	53"	30"	27"	2.4	30	495

\*\*Measured 2 feet from face of fan

\*Made in U.S.A. with domestic and foreign components.



**WARNING:** This product can expose you to chemicals including nickel which is known to the State of California to cause cancer, and chromium, which is known to the State of California to cause birth defects and/or reproductive harm. For more information go to [www.P65Warnings.ca.gov](http://www.P65Warnings.ca.gov).



\*Measured 2 feet from face of fan

# Industrial Mounted Workstation Fans



**WARNING:** This product can expose you to chemicals including nickel which is known to the State of California to cause cancer, and chromium, which is known to the State of California to cause birth defects and/or reproductive harm. For more information go to [www.P65Warnings.ca.gov](http://www.P65Warnings.ca.gov).

FAN SIZE	DIMENSIONS		
	"H"	"W"	"D"
12"	15 1/4"	14 1/2"	9 1/2"
18"	21 1/2"	20 1/2"	10 1/2"
24"	27"	26"	10 1/2"

## Features

- Pull chain switch
- Head rotates 360° vertically and horizontally
- Coated steel guards
- SJT type 3 conductor, 10' long cord
- Steel hub/spider aluminum paddle blades
- Meets OSHA standards / 1 Year limited warranty
- Imported to TPI specifications



## Motor Specifications

- Sleeve bearing
- Totally enclosed, permanently lubricated
- Frame size: 42
- 3-Speed
- 1-Phase, 120V
- 5/16" (12" fan only) and 1/2" shaft

## Standard Models

FAN SIZE	MFG CATALOG NUMBER	MFG MODEL NUMBER	MOTOR HP	CFM* / RPM			VELOCITY PROFILE	MAX AMPS	WT. (LBS)	LIST
				HIGH	MED	LOW	CFM / Area Sq Ft			
12"	07986002	U-12-TE	1/12	900 / 1590	800 / 1380	700 / 1080	1400 / 50	1.1	13	<b>246</b>
18"	07972802	U-18-TE	1/8	1800 / 1660	1500 / 1550	1300 / 1370	2900 / 125	2.2	20	<b>303</b>
24"	08540702	U-24-TE	1/8	2100 / 1634	1900 / 1484	1600 / 1200	3500 / 150	2.4	23	<b>341</b>
24"	08775502	U-24-TE-HV	1/4	3800 / 1100	3600 / 950	3400 / 800	6000 / 240	2.7	25	<b>362</b>

## Pipe Mount Adaptor

PIPE DIAMETER	MFG CATALOG NUMBER	MFG MODEL NUMBER	LIST
1"	08512402	PM-1	<b>80</b>
1 1/2"	08512502	PM-1.5	<b>89</b>
2"	08512602	PM-2	<b>98</b>
2 1/2"	08512702	PM-2.5	<b>105</b>
3"	08512802	PM-3	<b>115</b>

\*Measured 2 feet from face of fan

Note: Mount with one bolt or lag screw to walls, ceilings, work benches, machines or any surface.

FAN SIZE	MFG CATALOG NUMBER	MFG MODEL NUMBER	MOTOR HP	CFM* / RPM			MAX AMPS	DESCRIPTION	LIST
				HIGH	MED	LOW			
12"	08216102	U-12-TE-W	1/12	900/1590	800/1380	700/1080	1.1	12" Industrial Mounted Workstation Fan w/ Mounting Arm	<b>306</b>
18"	08216202	U-18-TE-W	1/8	1800/1660	1500/1550	1300/1370	2.2	18" Industrial Mounted Workstation Fan w/ Mounting Arm	<b>353</b>
MFG CATALOG NUMBER		MFG MODEL NUMBER		DESCRIPTION				LIST	
08215902		WCM-W-10		WORKSTATION MOUNTING ARM, 6" - 10"				<b>109</b>	
08216002		WCM-W-14		WORKSTATION MOUNTING ARM, 10" - 14"				<b>132</b>	



# Outdoor Rated Yoke Mount Fans

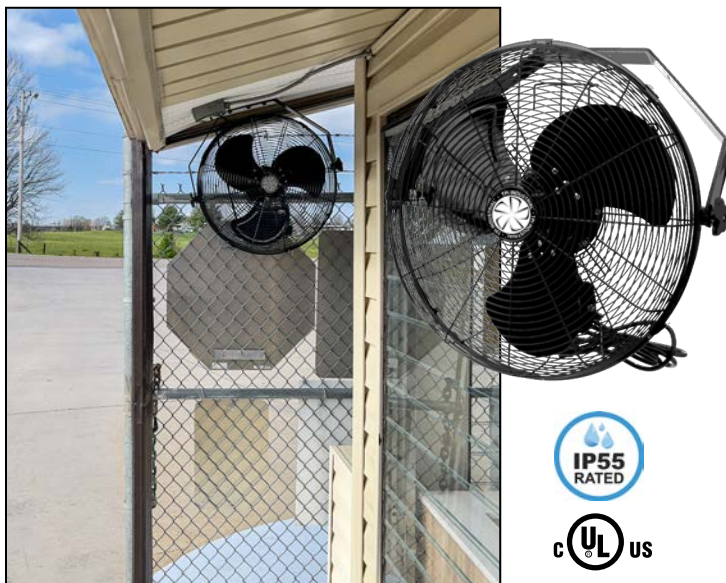

## Features

- Direct drive totally enclosed motor
- Pull chain switch
- Head rotates 360° vertically and horizontally
- Knobs allow for 180° vertical rotation
- Coated black finish steel guards
- Steel yoke mounting bracket
- All black finish with aiming handle
- SJT type 3 conductor, 10' long cord
- Steel hub/spider aluminum 3-paddle blades
- Meets OSHA standards / 1 Year limited warranty
- Imported to TPI specifications

## Motor Specifications

- Sleeve bearing
- Totally enclosed, permanently lubricated
- Frame size: 42
- 3-Speed
- 1-Phase, 120V
- 1/2" shaft

## Standard Models

FAN SIZE	MFG CATALOG NUMBER	MFG MODEL NUMBER	MOTOR HP	RPM	CFM			VELOCITY PROFILE	MAX AMPS	WT. (LBS)	LIST
					HIGH	MED	LOW	CFM/Area Sq. Ft.			
18"	08194502	U-18-TE-HD	1/10	1625	1900	1500	1300	3100 / 125	1.1	20	<b>350</b>
24"	08211802	U-24-TE-HD	1/4	1625	3800	3600	3400	6000 / 240	2.4	28	<b>375</b>

\*Measured 2 feet from face of fan



CF-20

### Features

- Rotary switch
- SJT type cord - 3 conductor - 7' long
- Aluminum blade
- Coated steel guards with retaining clips
- Meets OSHA standards / 1 Year limited warranty
- Imported to TPI specifications

### Motor Specification

- 3-Speed
- 120V
- Sleeve bearing
- 1-Phase
- Open ventilated
- Permanently lubricated

**WARNING:** This product can expose you to chemicals including nickel which is known to the State of California to cause cancer, and chromium, which is known to the State of California to cause birth defects and/or reproductive harm. For more information go to [www.P65Warnings.ca.gov](http://www.P65Warnings.ca.gov).

### Standard Models

MFG CATALOG NUMBER	MFG MODEL NUMBER	SIZE	TYPE	MOTOR HP	CFM			MAX AMPS	WT. (LBS)	LIST
					HIGH	MED	LOW			
08723002	CF-12	12"	FLOOR	1/30	1050	875	750	0.48	10	<b>137</b>
08723102	CF-18	18"	FLOOR	1/16	1600	1480	1380	1.15	16	<b>170</b>
08706502	CF-20	20"	FLOOR	1/12	1725	1600	1480	1.21	18	<b>234</b>

Note: Units should be used in clean, dry, commercial applications.

Note: Photograph is a representation of stocked models. Actual model may vary in appearance.

## Workstation Oscillating Office Fans

### Features

- 3-speed oscillating fans with push button controls
- 3 conductor SPT cord & plug
- White powder coated wire mesh guards
- White plastic housing and blade
- Stand fan extends to 40" height
- Meets OSHA standards / 1 Year limited warranty
- Imported to TPI specifications

**WARNING:** This product can expose you to chemicals including nickel which is known to the State of California to cause cancer, and chromium, which is known to the State of California to cause birth defects and/or reproductive harm. For more information go to [www.P65Warnings.ca.gov](http://www.P65Warnings.ca.gov).



STAND FAN



DESK FAN



### Standard Models

SIZE	MFG CATALOG NUMBER	MFG MODEL NUMBER	FAN TYPE	SPEEDS	CFM HIGH	AMPS HIGH	WT. (LBS)	LIST
12"	08513002	ODF-12	DESK	3	860	0.4	5.4	<b>117</b>
16"	08513102	ODF-16	DESK	3	1530	0.5	8.5	<b>137</b>
16"	08513202	OSF-16	STAND	3	1530	0.5	15.5	<b>173</b>

# Workstation Wall Mount Fan With Pivoting Arm

## 18" HIGH VELOCITY FAN MOUNTED ON 24", 40", or 60" PIVOTING ARMS



**WARNING:** This product can expose you to chemicals including nickel which is known to the State of California to cause cancer, and chromium, which is known to the State of California to cause birth defects and/or reproductive harm. For more information go to [www.P65Warnings.ca.gov](http://www.P65Warnings.ca.gov).

### Mounting Arm Features

- 1 1/2" square, 14 gauge, steel tubing
- 3" x 5" x 3/16" mounting plate attaches with (4) 3/8" bolts
- 5' long, 18/3 SJTW conductor cord and NEMA 5-15 grounded plug
- Dual electrical outlets embedded in arm to allow connection of modular fan and optional light
- Made in U.S.A. with domestic and foreign components



### Modular Fan Features

- 18" high velocity circulator, with 3 speed, 1/8 HP, 115V, 1-Phase permanently lubricated, totally enclosed, PSC motor
- Modular fan plugs into electrical outlet on arm
- Coated steel guards / Aluminum blades
- Meets OSHA standards / 1 year limited warranty
- Use on loading docks to cool off workers entering hot truck trailers.
- Use at factory workstations to cool off people or the machines.

### Standard Models

MFG CATALOG NUMBER	MFG MODEL NUMBER	FAN SIZE	ARM LENGTH	FAN CFM*			VELOCITY PROFILE	MAX AMPS	WT. (LBS)	LIST		
				HIGH	MED	LOW	CFM / Area Sq Ft					
08009102	24-LDF-TE	18"	24"	1800	1500	1300	2900 / 125	2.2	31	480		
08009202	40-LDF-TE		40"								38	600
08009302	60-LDF-TE		60"									

\*Measured 2 feet from face of fan

### Loading Dock Arm Fan

MFG CATALOG NUMBER	MFG MODEL NUMBER	FAN SIZE	FAN CFM*			MAX AMPS	WT. (LBS)	LIST
			HIGH	MED	LOW			
07971802	LDF-18-TE	18"	1800	1500	1300	2.2	20	308

### Optional Modular Lights



DKL-INC



### Light Features

- Plugs into embedded outlet in arm
- On/off switch and wire guard included
- LED bulb included with DKLED-30W-SP
- Safety yellow finish for higher visibility

### Standard Models

**WARNING:** This product can expose you to chemicals including nickel which is known to the State of California to cause cancer, and chromium, which is known to the State of California to cause birth defects and/or reproductive harm. For more information go to [www.P65Warnings.ca.gov](http://www.P65Warnings.ca.gov).

MFG CATALOG NUMBER	MFG MODEL NUMBER	LIGHT HEAD TYPE	MAX WATTS	MAX LUMENS	AVE. BULB LIFE (HRS)	WT. (LBS)	LIST
04465602	DKL-INC	Incandescent	300	3,700	2,000	5	128

# Low Velocity "Special Application" Workstation Fan



WALL MOUNT



BENCH MOUNT

CEILING MOUNT

**WARNING:** This product can expose you to chemicals including nickel which is known to the State of California to cause cancer, and chromium, which is known to the State of California to cause birth defects and/or reproductive harm. For more information go to [www.P65Warnings.ca.gov](http://www.P65Warnings.ca.gov).

### Features

- 12" aluminum blade air circulator for wall, ceiling, or bench mount
- 120V, 1-phase, 1/12HP with direct wire electrical connection
- Toggle switch with 2-speed control generating up to 1200 CFM
- All metal construction with a gray powder coated finish
- Fan head tilts 90° in horizontal and vertical plane
- Conforms to U.S. Navy Specification MIL-DTL-68G
- Meets OSHA standards / 1-year limited warranty
- Made in the U.S.A. with domestic and foreign components

### Standard Models

SIZE	MFG CATALOG NUMBER	MFG MODEL NUMBER	MOTOR HP	CFM* / RPM		VELOCITY PROFILE	AMPS HIGH	WT. (LBS)	LIST
				HIGH	LOW	CFM / Area Sq Ft			
12"	08708902	N-12	1/12	800 / 1350	600 / 1000	1200 / 40	0.6	12	501

\*Measured 2 feet from face of fan

# Industrial Ceiling Fans

## Features

- 120-Volt / single phase, 60HZ electrical service
- Permanently sealed ball bearing brushless DC motor provides maintenance free and quiet operation
- Low energy consumption – high efficiency performance
- White powder coated finish on steel motor housing & downrod
- White polymer 3-paddle blade system designed for quiet operation
- Includes 24" stainless steel safety cable kit
- Easy to mount to the supplied steel J-Hook connection
- Satisfies the U.S. Department of Energy's "Energy Guide" requirements
- Forward and reverse available when used with optional speed controller to provide year round operation. (E56-CF-D & E60-CF-D)
- E60-CFC-D has 5 speeds, includes cord/controller & IP65 rated equivalent for wet locations
- ETL Listed for USA & Canada / 5-year limited warranty

Models: E56-CF-D or E60-CF-D



forward/reverse wiring options



Model: E60-CFC-D

Indoor / Outdoor Rated  
Plug & Play Install  
Includes Speed Controller



**WARNING:** This product can expose you to chemicals including nickel which is known to the State of California to cause cancer, and chromium, which is known to the State of California to cause birth defects and/or reproductive harm. For more information go to [www.P65Warnings.ca.gov](http://www.P65Warnings.ca.gov).



## Motor Specifications

	Model #	Amps	Watts
• 1-Phase, 120V	E-56CF-D	0.46	30
• Permanent sealed	E-60CF-D	0.46	30
• Ball bearing PSC AC Motor	E-60CFC-D	0.46	30
• Energy Consumption			

## Standard Models

MFG CATALOG NUMBER	MFG MODEL NUMBER	BLADE DIAMETER	AIRFLOW OPTIONS	DOWNROD LENGTH	MAX CFM	MOTOR RPM	MOTOR TYPE	CORD INCLUDED	SPEED CONTROLLER	WEIGHT (LBS.)	LIST
08198202	E-56CF-D	56"	Forward/Reverse	18"	6,858	255	Moisture Rated	None	Sold Separately	15.7	331
08198302	E-60CF-D	60"	Forward/Reverse	18"	7,234	240	Moisture Rated	None	Sold Separately	15.9	408
08198402	E-60CFC-D	60"	Forward/Reverse	24"	7,234	240	Wet Rated	Yes	Included; 6 speeds	17.2	641

## Accessories

MFG CATALOG NUMBER	MFG MODEL NUMBER	DESCRIPTION	LIST
08220302	E-C-CF-D	DC Speed Controller (Max # of fans: 4)	130

## How to Determine the Total # of Ceiling Fans Needed

Ceiling Height (feet)	Coverage Area (square feet)
10 - 11	600
12 - 13	800
14 - 15	900
16 - 17	1000
18 - 19	1100
20 - 20+	1200

### What to Measure:

Total Square Footage (L x W)  
Maximum Ceiling Height

### Small Area Example:

If you had a 3,000 square foot facility with 16' ceilings:  
**Calculation** (Total Sq.Ft. / Coverage Area): 3,000/1,100 = 2.73  
**Total # of fans needed = 3**

### Large Area Example:

If you had a 10,000 square foot facility with 13' ceilings:  
**Calculation** (Total Sq.Ft. / Coverage Area): 10,000/800 = 12.5  
**Total # of fans needed = 12** (See chart for layout)

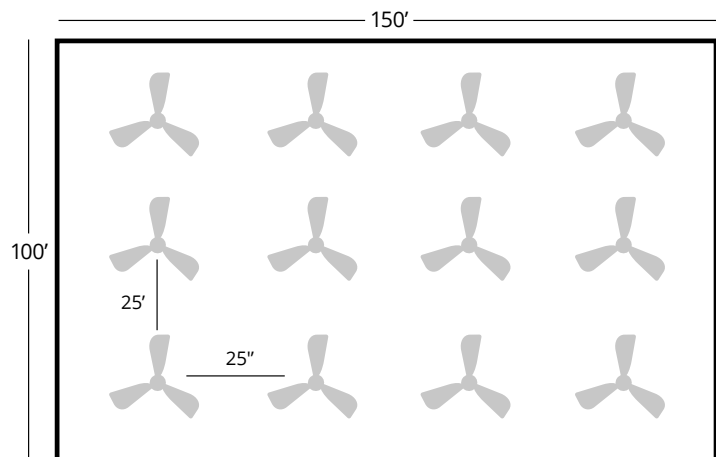

# Shutter Mounted Direct Drive Exhaust Fans

## Features

- Can be installed from inside wall to eliminate external framing
- Aluminum shutter framing includes weather seals
- Pull chain switch for on/off and speed control
- Aluminum paddle blade assembly, with steel spiral wire guard
- Junction box provided on all models
- **DS Models** - Direct wiring, no cord
- **DSC Models** - Includes 10' long SJT grounded cord
- Made in U.S.A. with domestic and foreign components



Rear View

## Motor Specifications

- 120V, 1-Phase, totally enclosed, permanently lubricated
- 1/20 HP motor is 3-speed sleeve bearing permanent split capacitor
- 1/8 HP motor is 3-speed sleeve bearing permanent split capacitor
- 1/4 HP motor is 2-speed ball bearing permanent split capacitor

**Note: Rough-in hole size is 1/2" inch larger than fan blade size**  
**Note: See sizing chart on page 17**



**WARNING:** This product can expose you to chemicals including nickel which is known to the State of California to cause cancer, and chromium, which is known to the State of California to cause birth defects and/or reproductive harm. For more information go to [www.P65Warnings.ca.gov](http://www.P65Warnings.ca.gov).

## Standard Models

FAN SIZE	MFG CATALOG NUMBER	MFG MODEL NUMBER	MFG CATALOG NUMBER	MFG MODEL NUMBER	HP	CFM / RPM			AMPS HIGH	LIST DS MODELS	LIST DSC MODELS
						HIGH	MED	LOW			
10"	08689902	CE 10-DS	08218402	CE 10-DSC	1/20	680 / 1560	540 / 1250	460 / 1080	0.8	<b>481</b>	<b>515</b>
12"	07986202	CE 12-DS	08218502	CE 12-DSC	1/20	825 / 1560	710 / 1250	560 / 1080	0.8	<b>546</b>	<b>580</b>
14"	08690002	CE 14-DS	08218602	CE 14-DSC	1/8	1520 / 1660	1400 / 1550	1250 / 1370	1.7	<b>690</b>	<b>725</b>
16"	08690102	CE 16-DS	08218702	CE 16-DSC	1/8	2100 / 1660	1900 / 1550	1700 / 1370	1.7	<b>722</b>	<b>756</b>
18"	07986302	CE 18-DS	08218802	CE 18-DSC	1/8	2300 / 1660	2100 / 1050	1850 / 1370	1.7	<b>785</b>	<b>819</b>
20"	08690202	CE 20-DS	08218902	CE 20-DSC	1/4	2925 / 1140	-	2380 / 1070	3.2	<b>931</b>	<b>965</b>
24"	07986402	CE 24-DS	08219002	CE 24-DSC	1/4	3400 / 1140	-	2770 / 1070	3.2	<b>1034</b>	<b>1067</b>
30"	07986502	CE 30-DS	08219102	CE 30-DSC	1/4	3950 / 1140	-	3080 / 1070	3.2	<b>1295</b>	<b>1329</b>

## Dimensions (Inches)

SIZE	DEPTH	DIMENSIONS			WT. (lbs)
		"A"	"B"	"C"	
10"	7.71	13.00	10"	12.375"	11
12"	9.08	15.00	12"	14.375"	16
14"	9.26	17.00	14"	16.75"	17
16"	9.26	19.00	16"	18.250"	18
18"	9.09	21.00	18"	21.750"	25
20"	9.30	23.00	20"	23.686"	34
24"	9.12	27.00	24"	27.750"	47
30"	9.12	33.00	30"	33.750"	54

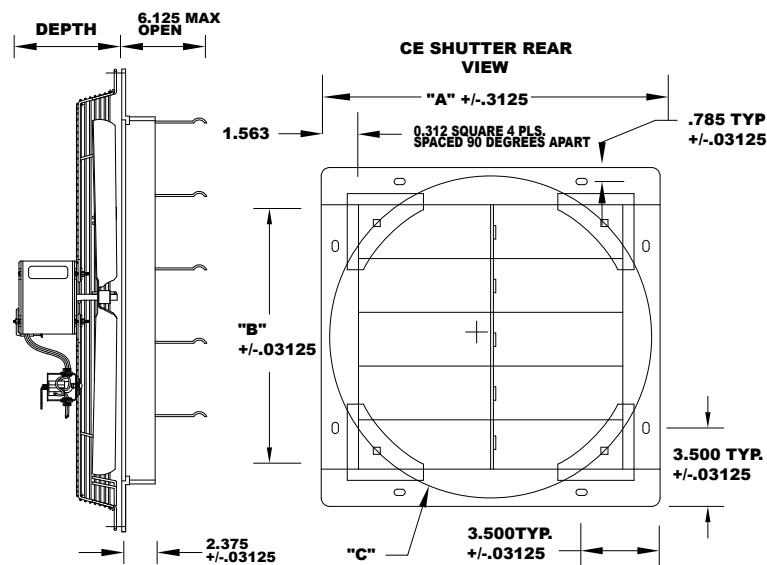



# Guard Mounted Direct Drive Exhaust Fans

## Features

- Bolts directly to the wall
- Can be used with or without external shutter
- Pull chain switch
- No cord-junction box provided for direct wiring
- Aluminum blade
- Steel spiral wire guards
- Made in U.S.A. with domestic and foreign components.

**⚠ WARNING:** This product can expose you to chemicals including nickel which is known to the State of California to cause cancer, and chromium, which is known to the State of California to cause birth defects and/or reproductive harm. For more information go to [www.P65Warnings.ca.gov](http://www.P65Warnings.ca.gov).



Rear View

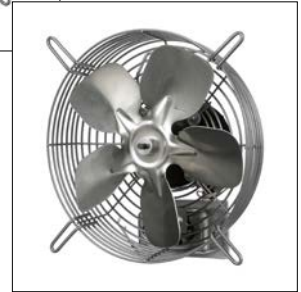

Front View

**Note:** Rough-in hole size is 1/2" inch larger than fan blade size  
**Note See sizing chart on page 17**

## Motor Specifications

- 120V, 1-Phase, totally enclosed, permanently lubricated
- 1/20 HP motor is 3-Speed sleeve bearing permanent split capacitor
- 1/8 HP motor is 3-Speed sleeve bearing permanent split capacitor
- 1/4 HP motor is 2-Speed ball bearing permanent split capacitor

## Standard Models

FAN SIZE	MFG CATALOG NUMBER	MFG MODEL NUMBER	HP	CFM / RPM			AMPS HIGH	WT. (LBS)	LIST
				HIGH	MED	LOW			
10"	08689502	CE 10-D	1/20	680 / 1560	540 / 1250	460 / 1080	0.8	11	<b>410</b>
12"	07985002	CE 12-D	1/20	825 / 1560	710 / 1250	560 / 1080	0.8	12	<b>462</b>
14"	08689602	CE 14-D	1/8	1520 / 1660	1400 / 1550	1250 / 1370	1.7	17	<b>491</b>
16"	08689702	CE 16-D	1/8	2100 / 1660	1900 / 1550	1700 / 1370	1.7	18	<b>513</b>
18"	07984902	CE 18-D	1/8	2300 / 1660	2100 / 1050	1850 / 1370	1.7	19	<b>563</b>
20"	08689802	CE 20-D	1/4	2925 / 1140	-	2380 / 1070	3.2	34	<b>732</b>
24"	07984802	CE 24-D	1/4	3400 / 1140	-	2770 / 1070	3.2	38	<b>814</b>
30"	07984702	CE 30-D	1/4	3950 / 1140	-	3080 / 1070	3.2	42	<b>950</b>

## Dimensions (Inches)

SIZE	BOLT HOLE CENTER WIDTH	DEPTH
10"	14.14"	7.15"
12"	16.46"	8.52"
14"	18.30"	8.70"
16"	20.34"	8.70"
18"	22.64"	8.52"
20"	25.46"	8.70"
24"	29.08"	8.52"
30"	34.89"	8.53"

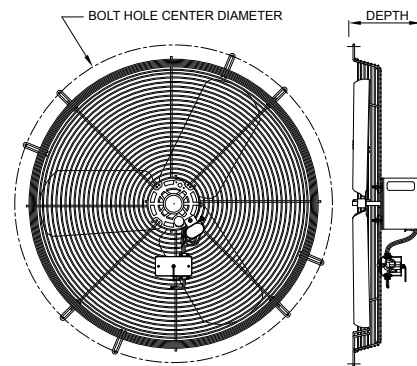

## Optional Wall Shutters

FAN SIZE	MFG CATALOG NUMBER	MFG MODEL NUMBER	WT. (LBS)	LIST
10"	08684302	CES-10G	5	<b>110</b>
12"	07985502	CES-12G	5.5	<b>152</b>
14"	08684502	CES-14G	6.5	<b>185</b>
16"	08514702	CES-16G	8	<b>215</b>
18"	07985602	CES-18G	9	<b>259</b>
20"	07975202	CES-20G	10	<b>288</b>
24"	07985702	CES-24G	13	<b>322</b>
30"	07985802	CES-30G	19	<b>375</b>

# Venturi Mounted Direct Drive Exhaust Fans

## Features

- Can be installed directly to an existing wall structure
- Designed to be used with or without external shutter
- Steel venturi-shaped mounting frame with powder coated gray finish
- Pull chain switch for on/off and speed control
- Aluminum paddle blade assembly, with steel spiral wire guard
- Junction box provided on all models
- **DV Models** - Direct wiring, no cord
- **DVC Models** - Includes 10' long SJT grounded cord
- Made in U.S.A. with domestic and foreign components

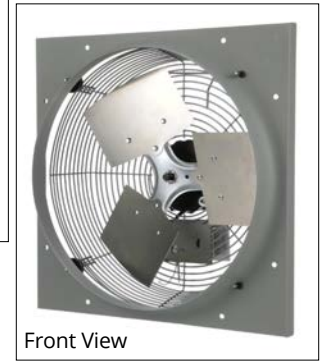

## Motor Specifications

- 120V, 1-Phase, totally enclosed, permanently lubricated
- 1/20 HP motor is 3-Speed sleeve bearing permanent split capacitor
- 1/8 HP motor is 3-Speed sleeve bearing permanent split capacitor
- 1/4 HP motor is 2-Speed ball bearing permanent split capacitor

**WARNING:** This product can expose you to chemicals including nickel which is known to the State of California to cause cancer, and chromium, which is known to the State of California to cause birth defects and/or reproductive harm. For more information go to [www.P65Warnings.ca.gov](http://www.P65Warnings.ca.gov).

**NOTE:** Rough-in hole size is 1 1/2 inch larger than fan blade size for models up to 20"; 2 1/2 for 24-30" models

## Standard Models

FAN SIZE	MFG CATALOG NUMBER	MFG MODEL NUMBER	MFG CATALOG NUMBER	MFG MODEL NUMBER	HP	CFM / RPM			AMPS HIGH	LIST DV	LIST DVC
						HIGH	MED	LOW			
10"	08690302	CE 10-DV	08217602	CE 10-DVC	1/20	680 / 1560	540 / 1250	460 / 1080	0.8	481	515
12"	07986602	CE 12-DV	80217702	CE 12-DVC	1/20	825 / 1560	710 / 1250	560 / 1080	0.8	545	580
14"	08690402	CE 14-DV	08217802	CE 14-DVC	1/8	1520 / 1660	1400 / 1550	1250 / 1370	1.7	690	725
16"	08690502	CE 16-DV	08217902	CE 16-DVC	1/8	2100 / 1660	1900 / 1550	1700 / 1370	1.7	722	756
18"	07986702	CE 18-DV	08218002	CE 18-DVC	1/8	2300 / 1660	2100 / 1050	1850 / 1370	1.7	785	819
20"	08690602	CE 20-DV	08218102	CE 20-DVC	1/4	2925 / 1140	-	2380 / 1070	3.2	931	965
24"	07986802	CE 24-DV	08218202	CE 24-DVC	1/4	3400 / 1140	-	2770 / 1070	3.2	1034	1067
30"	07986902	CE 30-DV	80218302	CE 30-DVC	1/4	3950 / 1140	-	3080 / 1070	3.2	1295	1329

## Dimensions (Inches)

SIZE	DEPTH	DIMENSIONS					WT. (LBS)
		"A"	"B" HEIGHT	"C"	"D"	"E"	
10"	7.6	10.250"	12.50"	12.375"	2.000"	12.81"	11
12"	8.96	12.250"	14.50"	14.375"	2.000"	14.625"	17
14"	9.15	14.250"	17.00"	17.375"	2.500"	17.375"	17
16"	9.15	16.250"	19.00"	18.250"	2.875"	20.000"	18
18"	8.97	18.125"	21.00"	21.750"	2.750"	22.875"	26
20"	9.19	20.250"	23.00"	23.686"	2.750"	25.625"	34
24"	9.01	24.250"	29.50" x 28.00"	27.750"	3.63"	--	48
30"	9.01	30.250"	35.50" x 34.00"	33.750"	3.63"	--	55

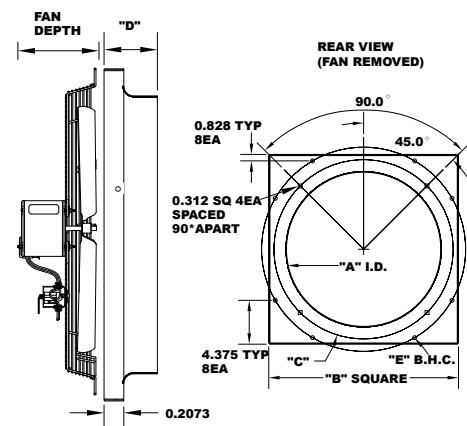

## Optional Wall Shutters

FAN SIZE	MFG CATALOG NUMBER	MFG MODEL NUMBER	DIMENSIONS		WT. (LBS)	LIST
			WIDTH	LENGTH		
10"	08684302	CES-10G	13.13"	13.13"	5.0	110
12"	07985502	CES-12G	15.13"	15.13"	5.5	152
14"	08684502	CES-14G	17.13"	17.13"	6.5	185
16"	08514702	CES-16G	19.00"	19.00"	8.0	215
18"	07985602	CES-18G	21.13"	21.13"	9.0	259
20"	07975202	CES-20G	23.13"	23.13"	10.0	288
24"	07985702	CES-24G	27.13"	27.13"	13.0	322
30"	07985802	CES-30G	33.13"	33.13"	19.0	375

# Belt Drive Exhaust Fans & Optional Shutters

## Venturi Mounted Belt Drive Exhaust Fan

### Features

- Steel venturi frame exhaust fan, bolts directly to an inside wall or framed / vertical surface
- Motor is designed for direct wiring connection; NO cord provided
- Operates at 115/120V at single-phase or 230/460V at 3-phase; 1725 RPMs
- Single speed, belt drive motor constructed of ball bearing, split capacitor, drip proof and is permanently lubricated
- Steel frame has a gray powder coated finish and uses a 4-paddle aluminum blade
- Designed for harsh industrial and commercial environments to improve air quality
- Belt drive motor allows for quieter operation and higher air volume performance
- Can be used with or without external shutter (sold separately)
- UL recognized motor has a frame size of 56
- Proudly designed, engineered, tested and assembled in the USA



### Dimensions (Inches)

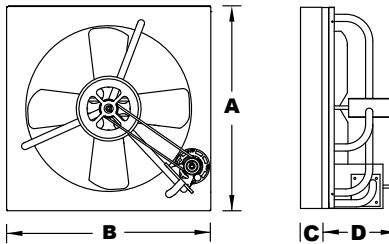

MODEL	DIMENSIONS A x B x C x D
CE-24B	29.5" x 28" x .75" x 17"
CE-30B	35.5" x 34" x .75" x 17"
CE-36B	41.5" x 40" x .75" x 17"
CE-42B	48" x 48" x .75" x 17"
CE-48B	54" x 54" x .75" x 17"

**WARNING:** This product can expose you to chemicals including nickel which is known to the State of California to cause cancer, and chromium, which is known to the State of California to cause birth defects and/or reproductive harm. For more information go to [www.P65Warnings.ca.gov](http://www.P65Warnings.ca.gov).

### Standard Models

SIZE	MOTOR HP	AMPS		CFM	WT. (LBS)	115V 1-PHASE			230/460V 3-PHASE		
		115V	230/460V			MFG CATALOG NUMBER	MFG MODEL NUMBER	LIST	MFG CATALOG NUMBER	MFG MODEL NUMBER	LIST
24	1/3	5	1.9 / .9	10,000	50	07967002	CE-24B	<b>1171</b>	08510402	CE-24B-3	<b>1348</b>
30	1/3	6	1.9 / .9	11,600	60	07967102	CE-30B	<b>1318</b>	08510502	CE-30B-3	<b>1504</b>
36	1/2	8	2.3 / 1.1	14,000	65	07967202	CE-36B	<b>1523</b>	08510602	CE-36B-3	<b>1701</b>
42	3/4	11	3.3 / 1.5	17,500	75	07967302	CE-42B	<b>1910</b>	08510702	CE-42-B-3	<b>2370</b>
48	1	15	3.8 / 1.9	23,500	98	07967402	CE-48B	<b>2387</b>	08510802	CE-48-B-3	<b>2525</b>

### Optional Exhaust Shutters



### Features

- Air open - gravity close
- Aluminum frame
- Aluminum louvers
- Weather stripping for tighter seal
- For ONLY CE-Series BELT Drive Fans
- Made in U.S.A.

### Standard Models

MFG CATALOG NUMBER	MFG MODEL NUMBER	WT. (LBS)	LIST
07967502	CES-24	11	<b>394</b>
07967602	CES-30	15	<b>481</b>
07967702	CES-36	19	<b>844</b>
07967802	CES-42	23	<b>1073</b>
07967902	CES-48	28	<b>1235</b>

### Shutter Dimensions (Inches)

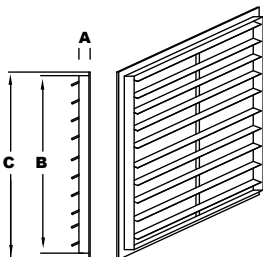

- (A) Thickness
- (B) Blade Housing Size
- (C) Overall Size

MFG MODEL NUMBER	OUTSIDE FRAME DIMENSIONS A x C x C	INSIDE FRAME DIMENSIONS B x B
CES-24	3" x 27" x 27"	24" x 24"
CES-30	3" x 33" x 33"	30" x 30"
CES-36	3" x 39" x 39"	36" x 36"
CES-42	3" x 45" x 45"	42" x 42"
CES-48	3" x 51" x 51"	48" x 48"

\* Recommend adding 1/2" to inside frame dimension for wall opening

# Industrial Direct Drive Exhaust Fans

## Features

- Totally enclosed motors:
  - 1-Phase motors are field convertible 115V / 230V
  - 3-Phase motors are field convertible 230V / 460V
  - Motors are set to lower voltage at the factory, unless a request is made at time of order to set to the higher voltage
- 14 gauge steel venturi with steel pipe bracing
- 4-blade steel propeller
- 1 year limited warranty



## Options

- CES Shutters
- EMF Front Guards
- IBG Rear Guards

**⚠ WARNING:** This product can expose you to chemicals including nickel which is known to the State of California to cause cancer, and chromium, which is known to the State of California to cause birth defects and/or reproductive harm. For more information go to [www.P65Warnings.ca.gov](http://www.P65Warnings.ca.gov).

## Standard Models

BLADE SIZE	MFG MODEL NUMBER		PANEL SIZE (Sq.)	HP	RPM	CFM 0" SP	db's @ 10'	WT. (LBS)	LIST	
	1-PHASE	3-PHASE							TEC	
	115/230V-60Hz	208/230/460v-60Hz							1 PH	3 PH
12"	IED12-1/4	IED12-1/4-3	16"	1/4	1725	1480	64	30	<b>2001</b>	<b>2007</b>
16"	IED16-1/3	IED16-1/3-3	20"	1/3	1725	2834	73	40	<b>2394</b>	<b>2444</b>
18"	IED18-1/2	IED18-1/2-3	24"	1/2	1725	3890	74	55	<b>2691</b>	<b>2713</b>
20"	IED20-3/4	IED20-3/4-3	24"	3/4	1725	4574	77	65	<b>3124</b>	<b>3124</b>
24"	IED24-1	IED24-1-3	30"	1	1725	6632	81	155	<b>3606</b>	<b>3411</b>
30"	IED30-1	IED30-1-3	36"	1	1150	8600	79	185	<b>7060</b>	<b>4087</b>
36"	IED36-1 1/2	IED36-1 1/2-3	42"	1.5	1150	12103	82	260	<b>8898</b>	<b>5466</b>
42"	-----	IED42-2-3	48"	2	1150	17315	87	280	--	<b>5859</b>
48"	-----	IED48-3-3	54"	3	850	24280	86	360	--	<b>8215</b>

**Note:** Products listed in this section are custom built and subject to 100% cancellation/restocking charges

## Dimensions

SIZE	BLADE DIAMETER	PANEL SIZE	DEPTH DIMENSION
12"	12"	16"	11"
16"	16"	20"	11"
20"	20"	24"	13"
24"	24"	30"	15"
30"	30"	36"	15"
36"	36"	42"	18"
42"	42"	48"	18"
48"	48"	54"	20"

**Note:** Depth dimension varies with motor selection

# Industrial Belt Drive Exhaust Fans

## Features

- Totally enclosed motors:
  - 1-Phase motors are field convertible 115V / 230V
  - 3-Phase motors are field convertible 230V / 460V
  - Motors are set to lower voltage at the factory, unless a request is made at time of order to set to the higher voltage
- 16 gauge steel venturi with steel pipe bracing
- Steel blades
- Double pillow block bearing shaft support
- 1 year limited warranty



**⚠ WARNING:** This product can expose you to chemicals including nickel which is known to the State of California to cause cancer, and chromium, which is known to the State of California to cause birth defects and/or reproductive harm. For more information go to [www.P65Warnings.ca.gov](http://www.P65Warnings.ca.gov).

## Options

- CES Shutters
- EMF Front Guard
- IBG Rear Guards

## Standard Models

BLADE SIZE	MFG MODEL NUMBER		PANEL SIZE (Sq.)	HP	RPM	CFM	db's @ 10'	WT. (LBS)	LIST	
	1-PHASE	3-PHASE							1 PH	3PH
	115/230V-60Hz	208/230/460v-60Hz								
24"	IE24-1/3	IE24-1/3-3	30"	1/3	825	5300	61	70	3474	3502
	IE24-1/2	IE24-1/2-3		1/2	925	6200	66	75	3588	3608
	IE24-3/4	IE24-3/4-3		3/4	1050	7000	71	82	3885	3648
	IE24-1	IE24-1-3		1	1175	7800	73	90	3926	3740
30"	IE30-1/3	IE30-1/3-3	36"	1/3	570	7500	62	95	3635	3662
	IE30-1/2	IE30-1/2-3		1/2	625	8500	64	95	4052	3777
	IE30-3/4	IE30-3/4-3		3/4	725	10000	66	105	4059	3830
	IE30-1	IE30-1-3		1	825	11000	70	115	4149	3961
36"	IE36-1/3	IE36-1/3-3	42"	1/3	425	9000	64	103	4000	4021
	IE36-1/2	IE36-1/2-3		1/2	500	10500	66	105	4121	4149
	IE36-3/4	IE36-3/4-3		3/4	575	11900	68	110	4483	4192
	IE36-1	IE36-1-3		1	650	13100	70	120	4461	4274
	IE36-1 1/2	IE36-1 1/2-3		1 1/2	750	15000	72	155	5098	4867
	IE36-2	IE36-2-3		2	830	16500	74	165	----	4967
42"	IE42-3/4	IE42-3/4-3	48"	3/4	430	14000	67	175	5000	4772
	IE42-1	IE42-1-3		1	490	15400	69	180	5036	4859
	IE42-1 1/2	IE42-1 1/2-3		1 1/2	550	17200	71	185	5276	5052
	IE42-2	IE42-2-3		2	620	19400	74	200	----	5762
	-----	IE42-3-3		3	700	22000	79	225	----	5960
48"	IE48-3/4	IE48-3/4-3	54"	3/4	350	17000	70	185	5471	5240
	IE48-1	IE48-1-3		1	400	19100	71	190	5510	5328
	IE48-1 1/2	IE48-1 1/2-3		1 1/2	460	22000	72	200	5738	5515
	IE48-2	IE48-2-3		2	520	24000	74	250	----	6420
	-----	IE48-3-3		3	590	27500	80	260	----	6619
	-----	IE48-5-3		5	660	30500	83	280	----	6670
60"	IE60-2	IE60-2-3	66"	2	320	31000	77	320	----	8933
	-----	IE60-3-3		3	370	35000	84	330	----	9129
	-----	IE60-5-3		5	420	39000	86	350	----	9207

**Note: Products listed in this section are custom built and subject to 100% cancellation/restocking charges**

## Dimensions

SIZE	BLADE DIAMETER	PANEL SIZE	DEPTH DIMENSION
24"	24"	30"	18"
30"	30"	36"	18"
36"	36"	42"	20"
42"	42"	48"	20"
48"	48"	54"	22"
60"	60"	66"	28"

**Note: Depth dimension varies with motor selection**

# Heavy Duty Direct Drive Exhaust Fans

## Features

- Totally enclosed and explosion proof motors
  - Explosion proof motors are Class 1, Div 1
  - Group D and Class 2, Div 1, Groups F & G
- Fans are shipped completely assembled
- Cast aluminum blades
- 14 gauge steel panel with welded steel pipe bracing
- 1 year limited warranty

**WARNING:** This product can expose you to chemicals including nickel which is known to the State of California to cause cancer, and chromium, which is known to the State of California to cause birth defects and/or reproductive harm. For more information go to [www.P65Warnings.ca.gov](http://www.P65Warnings.ca.gov).



## Options

- CES Shutters
- EMF Front Guards
- IBG Rear Guards
- Acid Resistant Coating
- Reversed Air Flow
- Flat Front Venturi

## Standard Models

BLADE SIZE	MFG MODEL NUMBER		PANEL SIZE (Sq.)	HP	RPM	CFM @ 1" SP	db's @ 10'	WT. (LBS)	LIST			
	1-PHASE	3-PHASE							TEC		EXP*	
	115/230V-60Hz	208/230/460v-60Hz							1 PH	3 PH	1 PH	3 PH
12"	EHD12-1/4	EHD12-1/4-3	16"	1/4	1725	1180	74	35	2532	2517	3171	3278
16"	EHD16-1/4	EHD16-1/4-3	20"	1/4	1725	2800	75	45	3089	3107	3729	3837
18"	EHD18-1/3	EHD18-1/3-3	24"	1/3	1725	3375	75	60	3278	3304	4114	4338
	EHD18-1/2	EHD18-1/2-3		1/2	1725	4150	76	60	3420	3442	4402	4355
20"	EHD20-1/4	EHD20-1/4-3	24"	1/4	1725	3720	75	60	3136	3119	3780	3881
	EHD20-1/2	EHD20-1/2-3		1/2	1725	4800	76	65	3377	3405	4363	4320
	EHD20-1	EHD20-1-3		1	1725	6900	77	70	3773	3593	4715	4796
24"	EHD24-1/4	EHD24-1/4-3	30"	1/4	1725	5200	82	135	3325	3304	3967	4077
	EHD24-1/3	EHD24-1/3-3		1/3	1150	4975	75	145	4021	4077	5386	5462
	EHD24-1/2	EHD24-1/2-3		1/2	1725	6510	82	140	3684	3698	4661	4618
	EHD24-3/4	EHD24-3/4-3		3/4	1725	6900	83	145	3978	3752	4968	4727
	EHD24-1	EHD24-1-3		1	1725	7425	83	155	4087	3898	5031	5108
	EHD24-2	EHD24-2-3		2	1725	9525	83	165	5155	4230	---	5642
	-----	EHD24-3-3		3	1725	10500	85	170	---	4597	---	6104
30"	EHD30-1/3	EHD30-1/3-3	36"	1/3	1150	6950	79	145	4402	4456	5763	5849
	EHD30-1/2	EHD30-1/2-3		1/2	1725	8980	89	135	4097	4114	5074	5031
	EHD30-3/4	EHD30-3/4-3		3/4	1150	10440	79	175	5244	4679	6044	5865
	-----	EHD30-1-3		1	870	10640	74	215	---	5783	---	---
	EHD30-1 1/2	EHD30-1 1/2-3		1 1/2	1725	12000	89	165	4771	4535	7365	5935
	EHD30-2	EHD30-2-3		2	1150	14000	82	215	---	5407	---	7011
	-----	EHD30-3-3		3	1725	16000	89	190	---	4859	---	6358
36"	EHD36-1	EHD36-1-3	42"	1	1150	13600	84	225	7550	6034	9069	7157
	-----	EHD36-2-3		2	1150	17620	84	250	---	6211	---	7821
	-----	EHD36-3-3		3	1150	20500	85	255	---	7140	---	9032
	-----	EHD36-5-3		5	1725	28000	94	250	---	5989	---	7633
42"	-----	EHD42-1-3	48"	1	870	15800	82	300	---	7011	---	---
	EHD42-2	EHD42-2-3		2	1150	17964	88	260	---	6607	---	8216
	-----	EHD42-3-3		3	1150	24500	88	270	---	7425	---	9318
	-----	EHD42-5-3		5	1150	28970	88	285	---	7721	---	10423
48"	-----	EHD48-3-3	54"	3	1150	28600	92	290	---	8959	---	10855
	-----	EHD48-5-3		5	1150	32000	94	305	---	9385	---	12092
60"	-----	EHD60-3-3	66"	3	1150	40000	97	700	---	11126	---	13015
	-----	EHD60-5-3		5	1150	45000	97	730	---	12174	---	14886
	-----	EHD60-7 1/2-3		7 1/2	870	47000	92	740	---	15989	---	---
	-----	EHD60-10-3		10	870	57200	93	750	---	21426	---	---

Single phase motors are field convertible 115V/230V. Three phase motors are field convertible 230V/460V. Motors are set to lower voltage at the factory, unless a request is made at time of order to set to the higher voltage. Note: Products listed in this section are custom built and subject to 100% cancellation/restocking charges  
 \*Not all EXP motors are 208V capable

## Dimensions

SIZE	BLADE DIAMETER	PANEL SIZE	DEPTH DIMENSION
12"	12"	16"	11"
16"	16"	20"	11"
20"	20"	24"	13"
24"	24"	30"	15"
30"	30"	36"	15"
36"	36"	42"	18"
42"	42"	48"	18"
48"	48"	54"	20"
60"	60"	66"	22"

Note: Depth dimension varies with motor selection

# Heavy Duty Belt Drive Exhaust Fans

## Features

- Totally enclosed and explosion proof motors
  - Explosion proof motors are Class 1, Div 1
  - Group D and Class 2, Div 1, Groups F & G
- Fans are shipped completely assembled
- Heavy gauge steel blades on TEC models
- Cast aluminum blades on EXP explosion proof models
- 14 gauge steel panel with welded steel pipe bracing year limited warranty
- For optimum shutter efficiency, mount shutter  $\frac{1}{3}$  the distance of the fan opening size.
- Example: 36" fan shutter would be mounted 12" from the fan blade

## Options

- CES Shutters
- EMF Front Guards
- IBG Rear Guards
- Reversed Air Flow
- Flat Front Venturi



## Standard Models

BLADE SIZE	MFG MODEL NUMBER		PANEL SIZE (Sq.)	HP	RPM	CFM @ 0" SP	db's @ 10"	WT. (LBS)	LIST			
	1-PHASE	3-PHASE							TEC		EXP*	
	115/230V-60Hz	208/230/460v-60Hz							1 PH	3 PH	1 PH	3 PH
24"	EHB24-1/4	EHB24-1/4-3	30"	1/4	780	4900	60	100	4188	4168	5686	5796
	EHB24-1/2	EHB24-1/2-3		1/2	980	6219	66	130	4429	4446	6261	6207
	EHB24-3/4	EHB24-3/4-3		3/4	1140	7090	71	140	4734	4490	6576	6331
	EHB24-1	EHB24-1-3		1	1250	7180	73	140	5043	4849	6645	6735
30"	EHB30-1/4	EHB30-1/4-3	36"	1/4	540	7178	61	140	4465	4446	6253	6361
	EHB30-1/3	EHB30-1/3-3		1/3	595	7909	63	150	4544	4573	6522	6745
	EHB30-1/2	EHB30-1/2-3		1/2	640	8507	64	155	4661	4679	6818	6772
	EHB30-3/4	EHB30-3/4-3		3/4	770	10235	66	165	5068	4824	7232	6987
	EHB30-1	EHB30-1-3		1	975	10668	70	170	5326	5139	7292	7385
	EHB30-1 1/2	EHB30-1 1/2-3		1 1/2	1140	12473	77	180	5558	5309	9203	7761
36"	EHB36-1/3	EHB36-1/3-3	42"	1/3	460	9113	64	160	5282	5309	7096	7319
	EHB36-1/2	EHB36-1/2-3		1/2	530	10500	66	180	5409	5427	7552	7500
	EHB36-3/4	EHB36-3/4-3		3/4	605	11985	68	200	5757	5525	7902	7661
	EHB36-1	EHB36-1-3		1	665	13174	70	200	5796	5602	7914	7992
	EHB36-1 1/2	EHB36-1 1/2-3		1 1/2	720	13660	72	210	6530	6298	10029	8578
	EHB36-2	EHB36-2-3		2	870	16554	74	215	7213	6457	----	8892
42"	EHB42-1/3	EHB42-1/3-3	48"	1/3	335	10614	64	205	5496	5525	7761	7984
	EHB42-1/2	EHB42-1/2-3		1/2	390	12343	65	210	5613	5633	8028	7992
	EHB42-3/4	EHB42-3/4-3		3/4	435	14040	67	225	5983	5748	8497	8242
	EHB42-1	EHB42-1-3		1	490	15429	69	230	6062	5872	8502	8578
	EHB42-1 1/2	EHB42-1 1/2-3		1 1/2	550	17420	71	240	6307	6073	10442	8990
	EHB42-2	EHB42-2-3		2	725	20653	74	245	7473	6715	----	9387
	----	EHB42-3-3		3	830	23645	79	250	----	6936	----	9680
48"	EHB48-1/2	EHB48-1/2-3	54"	1/2	330	15230	69	190	6943	6960	9653	9609
	EHB48-3/4	EHB48-3/4-3		3/4	370	17339	70	195	7283	7049	10236	9994
	EHB48-1	EHB48-1-3		1	410	19188	71	235	7329	7140	10245	10337
	EHB48-1 1/2	EHB48-1 1/2-3		1 1/2	465	21731	72	245	7625	7392	12168	10713
	EHB48-2	EHB48-2-3		2	520	24274	74	250	8847	8092	----	11059
	----	EHB48-3-3		3	680	28150	80	270	----	8325	----	11388
	----	EHB48-5-3		5	800	33160	83	285	----	8423	----	11610
60"	EHB60-1	EHB60-1-3	66"	1	280	23090	76	380	10219	10029	13846	13936
	EHB60-1 1/2	EHB60-1 1/2-3		1 1/2	340	28068	77	390	10460	10230	15777	14330
	EHB60-2	EHB60-2-3		2	390	32200	78	395	11070	10327	----	14520
	----	EHB60-3-3		3	450	37183	84	410	----	10830	----	14996
	----	EHB60-5-3		5	540	44600	86	420	----	10911	----	15210

## Dimensions

SIZE	BLADE DIAMETER	PANEL SIZE	DEPTH DIMENSION
24"	24"	30"	16"
30"	30"	36"	16"
36"	36"	42"	18"
42"	42"	48"	20"
48"	48"	54"	21"
60"	60"	66"	26"

**WARNING:** This product can expose you to chemicals including nickel which is known to the State of California to cause cancer, and chromium, which is known to the State of California to cause birth defects and/or reproductive harm. For more information go to [www.P65Warnings.ca.gov](http://www.P65Warnings.ca.gov).

Note: Depth dimension varies with motor selection.

# Cabinet Exhaust Fans With Shutters

## Features

- 120V, 1-Phase or 230 / 460V, 3-phase, ball bearing, permanently lubricated, drip proof motor - UL listed
- Permanently lubricated bearings on blade drive shaft
- Aluminum blade
- Aluminum shutter
- 20-gauge powder coated venturi
- 18-gauge galvanized steel housing
- 1725 RPM motor
- Motor frame size 56 / Shaft: 5/8"
- Ships fully assembled
- Meets OSHA Standards
- 1 year warranty
- Made in U.S.A.

**WARNING:** This product can expose you to chemicals including nickel which is known to the State of California to cause cancer, and chromium, which is known to the State of California to cause birth defects and/or reproductive harm. For more information go to [www.P65Warnings.ca.gov](http://www.P65Warnings.ca.gov).



## Standard Models

SIZE	MOTOR HP	AMPS		CFM	WT. (LBS)	115V 1-PHASE			230 / 460V 3-PHASE		
		115V	230/460V			MFG CATALOG NUMBER	MFG MODEL NUMBER	LIST	MFG CATALOG NUMBER	MFG MODEL NUMBER	LIST
24	1/3	5	1.9 / .9	10,000	100	08683902	CBT-24B	<b>2477</b>	08685202	CBT-24B-3	<b>2634</b>
30	1/3	6	1.9 / .9	11,600	120	08684002	CBT-30B	<b>2789</b>	08685302	CBT-30B-3	<b>2992</b>
36	1/2	8	2.3 / 1.1	14,000	135	08684102	CBT-36B	<b>3147</b>	08685402	CBT-36B-3	<b>3407</b>
42	3/4	11	3.3 / 1.5	17,500	155	08684202	CBT-42B	<b>3872</b>	08685502	CBT-42B-3	<b>4176</b>
48	1	15	3.8 / 1.9	23,500	200	08685102	CBT-48B	<b>4797</b>	08685002	CBT-48B-3	<b>5108</b>

## Dimensions

SIZE	OUTSIDE DIMENSIONS			MAXIMUM REQUIRED INSIDE WALL OPENING
	HEIGHT	WIDTH	DEPTH	
24"	28 1/4"	28 1/4"	22 1/2"	28 3/4" x 28 3/4"
30"	34 1/4"	34 1/4"	22 1/2"	34 1/2" x 34 1/2"
36"	40 1/4"	40 1/4"	18 1/2"	40 1/2" x 40 1/2"
42"	48 1/2"	48 1/2"	18 1/2"	48 3/4" x 48 3/4"
48"	54 1/2"	54 1/2"	21 1/2"	54 3/4" x 54 3/4"



# Exhaust Fan Accessories - Heavy Duty Exhaust Shutter

## Features

- Air open - Gravity close
- Aluminum construction
- Heavy duty blades
- Weather stripping for tighter seal
- For optimum shutter efficiency, mount shutter 1/3 the distance of the fan opening size. Example: 36" fan shutter would be mounted 12" from the fan blade
- Shutter should be sized to fit exhaust opening
- For IE, IED, EHB and EHD models



## Standard Models

FAN SIZE	MFG CATALOG NUMBER	MFG MODEL NUMBER	INSIDE FRAME DIMENSIONS	OUTSIDE FRAME DIMENSIONS	WT. (LBS)	LIST
12"	07983302	CES 12-HD	12" x 12"	14" x 15"	4	<b>229</b>
16"	08709102	CES 16-HD	16" x 16"	19" x 19"	7	<b>276</b>
18"	08518902	CES 18-HD	18" x 18"	21" x 21"	8	<b>317</b>
20"	08696602	CES 20-HD	20" x 20"	23" x 23"	9	<b>324</b>
24"	08757202	CES 24-HD	24" x 24"	27" x 27"	11	<b>394</b>
30"	08757302	CES 30-HD	30" x 30"	33" x 33"	15	<b>481</b>
36"	08757402	CES 36-HD	36" x 36"	39" x 39"	19	<b>844</b>
42"	08757502	CES 42-HD	42" x 42"	45" x 45"	23	<b>1073</b>
48"	08757602	CES 48-HD	48" x 48"	51" x 51"	28	<b>1235</b>
54"	08775102	CES 54-HD	54" x 54"	57" x 57"	39	<b>1396</b>
60"	07998702	CES 60-HD	60" x 60"	63" x 63"	47	<b>1714</b>

**⚠ WARNING:** This product can expose you to chemicals including nickel which is known to the State of California to cause cancer, and chromium, which is known to the State of California to cause birth defects and/or reproductive harm. For more information go to [www.P65Warnings.ca.gov](http://www.P65Warnings.ca.gov).

## Heavy Duty Shutter Motor Kit Features



- Used to open shutter when shutter is used to provide make-up air (Shutter should be one size larger than exhaust fan size and should be located on opposite wall)
- Used for positive closure of exhaust shutter
- 115V or 230V, 60 HZ, 1-Phase

## Standard Models

MFG CATALOG NUMBER	MFG MODEL NUMBER	DESCRIPTION	WT. (LBS)	LIST
07971002	MK-1	For shutter sizes 12" thru 30" (Single Panel)	5	<b>637</b>
07971102	MK-2	For shutter sizes 36" thru 48" (Double Panel)	8	<b>844</b>
08777102	MK-3	For shutter sizes 54" thru 72" (Double Panel)	12	<b>1085</b>

## Motorized Supply Air Intake Shutter

### Features

- Inward opening blades for use with intake fans when shutter is located directly in air stream
- Galvanized construction
- 115V or 230V, 60 HZ, 1-Phase
- For IE, IED, EHB and EHD models

**⚠ WARNING:** This product can expose you to chemicals including nickel which is known to the State of California to cause cancer, and chromium, which is known to the State of California to cause birth defects and/or reproductive harm. For more information go to [www.P65Warnings.ca.gov](http://www.P65Warnings.ca.gov).

## Standard Models

FAN SIZE	MFG CATALOG NUMBER	MFG MODEL NUMBER	ROUGH OPENING	OVERALL SIZE	WT. (LBS)	LIST
24"	08516902	CESM-24	24" x 24"	27" x 27"	15	<b>1630</b>
30"	08007102	CESM-30	30" x 30"	33" x 33"	18	<b>1902</b>
36"	08004602	CESM-36	36" x 36"	39" x 39"	21	<b>2078</b>
42"	08517202	CESM-42	42" x 42"	45" x 45"	35	<b>3393</b>
48"	07997202	CESM-48	48" x 48"	51" x 51"	42	<b>4794</b>
60"	07983302	CESM-60	60" x 60"	63" x 63"	56	<b>5652</b>



## Rear Box Guard Bolt Together With Wire Guards



**WARNING:** This product can expose you to chemicals including nickel which is known to the State of California to cause cancer, and chromium, which is known to the State of California to cause birth defects and/or reproductive harm. For more information go to [www.P65Warnings.ca.gov](http://www.P65Warnings.ca.gov).

### Features

- For IE, IED, EHB and EHD models
- ¼" smaller than the panel size of the fan
- Meets OSHA requirements

### Standard Models

MFG MODEL NUMBER	FITS FAN SIZE	LIST
IBG-24	24"	1426
IBG-30	30"	1503
IBG-36	36"	1806
IBG-42	42"	1896
IBG-48	48"	2323
IBG-60	60"	3584

## Rear Expanded Metal Box Guard



**WARNING:** This product can expose you to chemicals including nickel which is known to the State of California to cause cancer, and chromium, which is known to the State of California to cause birth defects and/or reproductive harm. For more information go to [www.P65Warnings.ca.gov](http://www.P65Warnings.ca.gov).

### Features

- For IE, IED, EHB and EHD models
- ¼" smaller than the panel size of the fan
- Meets OSHA requirements

### Standard Models

MFG MODEL NUMBER	FITS FAN SIZE	LIST
IBG-12	12"	875
IBG-16	16"	875
IBG-18	18"	970
IBG-20	20"	970

## Spiral Front and Rear Guards

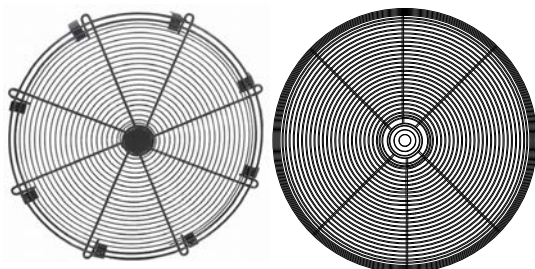

Spiral Front

Spiral Rear

**WARNING:** This product can expose you to chemicals including nickel which is known to the State of California to cause cancer, and chromium, which is known to the State of California to cause birth defects and/or reproductive harm. For more information go to [www.P65Warnings.ca.gov](http://www.P65Warnings.ca.gov).

### Features

- For EHD models only
- Fits between motor and blade
- Rear guard installed at factory only
- Meets OSHA requirements

### Standard Models

MFG MODEL NUMBER	TYPE	FITS FAN SIZE	LIST
SF-12	SPIRAL FRONT	12"	480
SF-16		16"	516
SF-18		18"	572
SF-20		20"	584
SF-24		24"	630
SR-12	SPIRAL REAR	12"	498
SR-16		16"	530
SR-18		18"	584
SR-20		20"	605
SR-24		24"	650

## Expanded Metal Front Guard

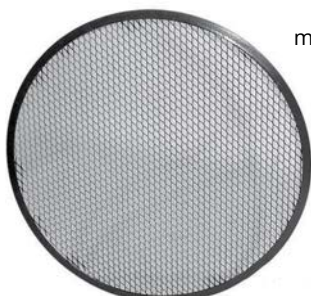

Expanded metal guard 60"

**WARNING:** This product can expose you to chemicals including nickel which is known to the State of California to cause cancer, and chromium, which is known to the State of California to cause birth defects and/or reproductive harm. For more information go to [www.P65Warnings.ca.gov](http://www.P65Warnings.ca.gov).

### Features

- For EHB, EHD, IE, & IED models
- 1" larger than blade size
- Meets OSHA requirements

### Standard Models

MFG MODEL NUMBER	FITS FAN SIZE	LIST
EMF-12	12"	575
EMF-16	16"	596
EMF-20	20"	629
EMF-24	24"	660
EMF-30	30"	835
EMF-36	36"	1033
EMF-42	42"	1086
EMF-48	48"	1186
EMF-60	60"	1789

# Cabinet Exhaust Fan Package Option

## With Bolt Together Rear Guard

### Package Includes

- Wall collar
- Automatic shutter
- Rear box guard

### Features

- For IE, IED, EHB and EHD models
- Wall collar OD is ¼" larger than fan panel size
- Meets OSHA requirements

### Standard Models

MFG MODEL NUMBER	FAN SIZE	LIST
CEFP-24	24"	<b>2546</b>
CEFP-30	30"	<b>2874</b>
CEFP-36	36"	<b>3569</b>
CEFP-42	42"	<b>4103</b>
CEFP-48	48"	<b>4898</b>

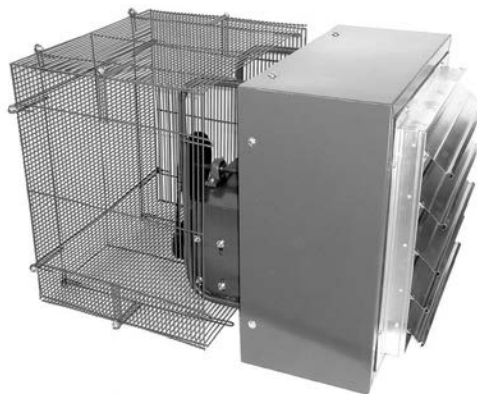

**WARNING:** This product can expose you to chemicals including nickel which is known to the State of California to cause cancer, and chromium, which is known to the State of California to cause birth defects and/or reproductive harm. For more information go to [www.P65Warnings.ca.gov](http://www.P65Warnings.ca.gov).

## With Expanded Metal Rear Guard

### Package Includes

- Wall collar
- Automatic shutter
- Rear box guard

### Features

- For IE, IED, EHB and EHD models
- Wall collar OD is ¼" larger than fan panel size
- Meets OSHA requirements

### Standard Models

MFG MODEL NUMBER	FAN SIZE	LIST
CEFP-12	12"	<b>1593</b>
CEFP-16	16"	<b>1701</b>
CEFP-18	18"	<b>1921</b>
CEFP-20	20"	<b>1993</b>
CEFP-60	60"	<b>7354</b>

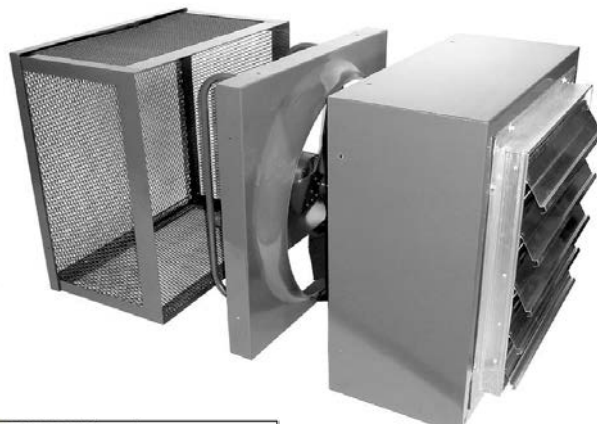

**WARNING:** This product can expose you to chemicals including nickel which is known to the State of California to cause cancer, and chromium, which is known to the State of California to cause birth defects and/or reproductive harm. For more information go to [www.P65Warnings.ca.gov](http://www.P65Warnings.ca.gov).

# Exterior Weather Hood Option

### Features

- For IE, IED, EHB and EHD models
- Galvanized housing with ½ - 16 expanded metal bird screen
- Can be used for intake or exhaust
- Meets OSHA requirements

### Standard Models

MFG MODEL NUMBER	FAN SIZE	LIST
WH-12	12"	<b>1602</b>
WH-16	16"	<b>1670</b>
WH-18	18"	<b>1707</b>
WH-20	20"	<b>1735</b>
WH-24	24"	<b>2466</b>
WH-30	30"	<b>2568</b>
WH-36	36"	<b>3186</b>
WH-42	42"	<b>3310</b>
WH-48	48"	<b>3830</b>
WH-60	60"	<b>5121</b>

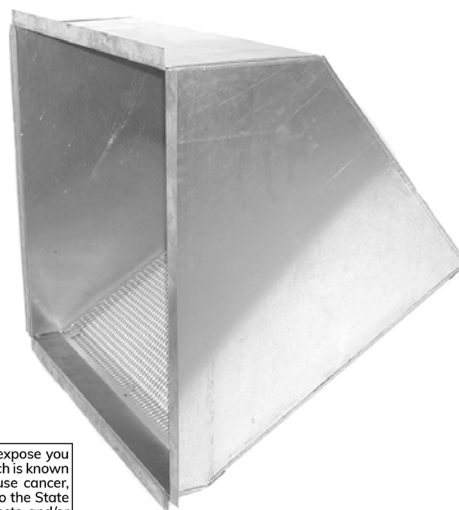

**WARNING:** This product can expose you to chemicals including nickel which is known to the State of California to cause cancer, and chromium, which is known to the State of California to cause birth defects and/or reproductive harm. For more information go to [www.P65Warnings.ca.gov](http://www.P65Warnings.ca.gov).

# Insulated Roof Curbs

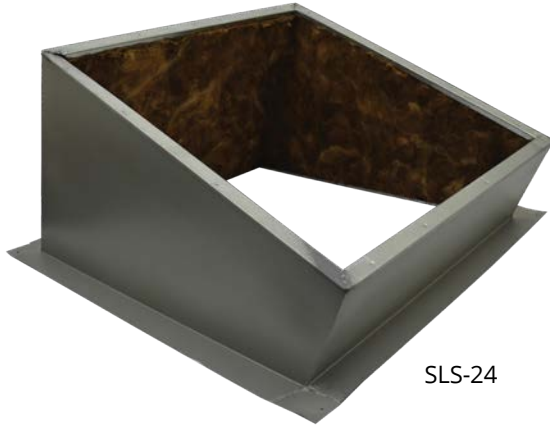

SLS-24

## Features

- Used with UEB, UED, and RE roof ventilators
- For flat, single slope or ridge style roofs
- Galvanized steel construction
- 1 1/2" insulated thickness, 3 pounds density
- 8" height overall
- Not for corrugated roofs

**⚠ WARNING:** This product can expose you to chemicals including nickel which is known to the State of California to cause cancer, and chromium, which is known to the State of California to cause birth defects and/or reproductive harm. For more information go to [www.P65Warnings.ca.gov](http://www.P65Warnings.ca.gov).

## Standard Models

FAN	MFG MODEL NUMBER			BASE DIMENSION	OVERALL DIMENSION	LIST		
	FLAT	SLOPE	RIDGE			FLAT	SLOPE	RIDGE
18"	FLS-18	SLS-18	RDS-18	32" x 32"	44" x 44"	<b>763</b>	<b>1472</b>	<b>1735</b>
24"	FLS-24	SLS-24	RDS-24	38" x 38"	50" x 50"	<b>881</b>	<b>1684</b>	<b>1976</b>
30"	FLS-30	SLS-30	RDS-30	44" x 44"	56" x 56"	<b>996</b>	<b>1886</b>	<b>2229</b>
36"	FLS-36	SLS-36	RDS-36	50" x 50"	62" x 62"	<b>1086</b>	<b>2068</b>	<b>2381</b>
42"	FLS-42	SLS-42	RDS-42	56" x 56"	68" x 68"	<b>1197</b>	<b>2268</b>	<b>2686</b>
48"	FLS-48	SLS-48	RDS-48	62" x 62"	74" x 74"	<b>1611</b>	<b>3050</b>	<b>3615</b>
54"	FLS-54	SLS-54	RDS-54	68" x 68"	80" x 80"	<b>1756</b>	<b>3314</b>	<b>3923</b>
60"	FLS-60	SLS-60	RDS-60	74" x 74"	86" x 86"	<b>1906</b>	<b>3606</b>	<b>4267</b>

## Back Draft Dampers to Fit in Curb

UEB and UED models require higher curb height when used with back draft damper; consult factory

FAN SIZE	MFG MODEL NUMBER	SHUTTER SIZE	LIST
18"	CD-18	28" x 28"	<b>1010</b>
24"	CD-24	34" x 34"	<b>1180</b>
30"	CD-30	40" x 40"	<b>1626</b>
36"	CD-36	46" x 46"	<b>2008</b>
42"	CD-42	52" x 52"	<b>2217</b>
48"	CD-48	58" x 58"	<b>2691</b>
54"	CD-54	64" x 64"	<b>3374</b>
60"	CD-60	70" x 70"	<b>3667</b>

## Motor Kit for Dampers

115V or 230V, 60Hz, 1-Phase. (Specify Voltage)

MFG MODEL NUMBER	DESCRIPTION	WT. (LBS)	LIST
DMKP1	For shutter sizes 18" thru 36"	5	<b>922</b>
DMKP2	For shutter sizes 42" thru 60"	8	<b>1100</b>

# Belt Drive Hooded Roof Ventilators

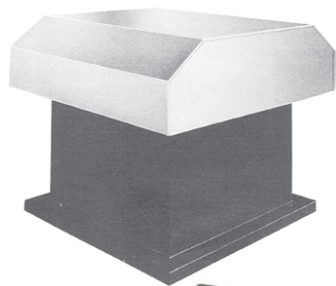

CLOSED



OPEN

**WARNING:** This product can expose you to chemicals including nickel which is known to the State of California to cause cancer, and chromium, which is known to the State of California to cause birth defects and/or reproductive harm. For more information go to [www.P65Warnings.ca.gov](http://www.P65Warnings.ca.gov).

## Features

- Used for exhaust or intake
- Heavy industrial steel base with aluminum hood
- Steel blades
- Bird screen included
- No back draft protection in standard construction Dampers offered as optional accessory
- 1 year limited warranty

## Options

- Direct drive
- Protective coatings
- Roof curb
- Filters

## Dimensions

SIZE	MINIMUM ROOF HOLE (SQUARE)	HOLE LENGTH x WIDTH	HOOD HEIGHT	ROOF CURB O.D. (SQUARE)
24"	30"	54" x 64"	30"	39"
30"	36"	60" x 76"	36"	45"
36"	42"	72" x 82"	40"	51"
42"	48"	80" x 89"	43"	57"
48"	54"	87" x 95"	46"	63"
54"	60"	92" x 98"	54"	69"
60"	66"	90" x 107"	56"	75"

## Standard Models

BLADE SIZE	1-PHASE 115/230V	3-PHASE 208/230/460v	HP	RPM	C.F.M - STATIC PRESSURE				Db's @ 10'	WT. (LBS)	LIST			
					MFG MODEL NUMBER						EXHAUST		INTAKE	
					0"	1/8"	1/4"	1/2"			1 PH	3 PH	1 PH	3 PH
24"	RE24-1/4	RE24-1/4-3	1/4	780	4900	4222	2807	800	60	340	<b>9600</b>	<b>9559</b>	<b>9600</b>	<b>9559</b>
	RE24-1/2	RE24-1/2-3	1/2	980	6219	5716	5061	2600	66	350	<b>9947</b>	<b>9844</b>	<b>9947</b>	<b>9844</b>
	RE24-3/4	RE24-3/4-3	3/4	1140	7090	6648	6144	4413	71	360	<b>10160</b>	<b>10001</b>	<b>10160</b>	<b>10001</b>
	RE24-1	RE24-1-3	1	1250	7180	6696	6271	4464	73	365	<b>10713</b>	<b>10407</b>	<b>10713</b>	<b>10407</b>
30"	RE30-1/3	RE30-1/3-3	1/3	595	7909	6380	3617	767	60	385	<b>11142</b>	<b>11081</b>	<b>11142</b>	<b>11081</b>
	RE30-1/2	RE30-1/2-3	1/2	640	8507	7170	4486	1373	64	385	<b>11313</b>	<b>11211</b>	<b>11313</b>	<b>11211</b>
	RE30-3/4	RE30-3/4-3	3/4	770	10235	9192	7657	3833	66	400	<b>11703</b>	<b>11540</b>	<b>11703</b>	<b>11540</b>
	RE30-1	RE30-1-3	1	975	10668	9959	8626	5184	70	400	<b>12090</b>	<b>11783</b>	<b>12090</b>	<b>11783</b>
36"	RE30-1 1/2	RE30-1 1/2-3	1.5	1140	12473	11867	11112	8135	77	410	<b>12335</b>	<b>11876</b>	<b>12335</b>	<b>11876</b>
	RE36-1/3	RE36-1/3-3	1/3	460	9113	6992	3722	486	64	425	<b>13501</b>	<b>13438</b>	<b>13501</b>	<b>13438</b>
	RE36-1/2	RE36-1/2-3	1/2	530	10500	8821	5985	2084	66	425	<b>13665</b>	<b>13560</b>	<b>13665</b>	<b>13560</b>
	RE36-3/4	RE36-3/4-3	3/4	605	11985	10583	8563	4017	68	435	<b>13937</b>	<b>13776</b>	<b>13937</b>	<b>13776</b>
	RE36-1	RE36-1-3	1	665	13174	11932	10299	5729	70	440	<b>14253</b>	<b>13947</b>	<b>14253</b>	<b>13947</b>
	RE36-1 1/2	RE36-1 1/2-3	1.5	720	13660	12012	9579	5000	72	440	<b>14814</b>	<b>14305</b>	<b>14814</b>	<b>14305</b>
42"	RE36-2	RE36-2-3	2	870	16554	15376	14088	9691	74	455	<b>15917</b>	<b>15053</b>	<b>15917</b>	<b>15053</b>
	RE42-1/2	RE42-1/2-3	1/2	390	12343	9352	4957	1642	65	540	<b>15144</b>	<b>15040</b>	<b>15144</b>	<b>15040</b>
	RE42-3/4	RE42-3/4-3	3/4	435	14040	11530	7633	3311	67	545	<b>15675</b>	<b>15512</b>	<b>15675</b>	<b>15512</b>
	RE42-1	RE42-1-3	1	490	15429	13194	10438	4668	69	555	<b>15990</b>	<b>15684</b>	<b>15990</b>	<b>15684</b>
	RE42-1 1/2	RE42-1 1/2-3	1.5	550	17420	15421	13117	7289	71	560	<b>16307</b>	<b>15798</b>	<b>16307</b>	<b>15798</b>
	RE42-2	RE42-2-3	2	725	20653	19128	17503	11319	74	570	<b>17298</b>	<b>16439</b>	<b>17298</b>	<b>16439</b>
48"	-----	RE42-3-3	3	830	23645	22296	20984	17290	79	585	----	<b>16646</b>	----	<b>16646</b>
	RE48-3/4	RE48-3/4-3	3/4	370	17339	13700	7389	2244	70	650	<b>18381</b>	<b>18218</b>	<b>18381</b>	<b>18218</b>
	RE48-1	RE48-1-3	1	410	19188	16078	10903	4037	71	660	<b>18706</b>	<b>18400</b>	<b>18706</b>	<b>18400</b>
	RE48-1 1/2	RE48-1 1/2-3	1.5	465	21731	19010	14991	7081	72	665	<b>18992</b>	<b>18484</b>	<b>18992</b>	<b>18484</b>
	RE48-2	RE48-2-3	2	520	24274	21943	19080	10125	74	680	<b>20085</b>	<b>19215</b>	<b>20085</b>	<b>19215</b>
	-----	RE48-3-3	3	680	28150	25683	23615	16930	80	700	----	<b>19459</b>	----	<b>19459</b>
54"	-----	RE48-5-3	5	800	33160	30900	29290	25000	83	720	----	<b>19614</b>	----	<b>19614</b>
	RE54-1	RE54-1-3	1	410	23130	20588	17500	9600	73	910	<b>22257</b>	<b>21950</b>	<b>22257</b>	<b>21950</b>
	RE54-1 1/2	RE54-1 1/2-3	1.5	450	25400	22600	19300	10316	75	920	<b>22707</b>	<b>22197</b>	<b>22707</b>	<b>22197</b>
	RE54-2	RE54-2-3	2	480	27200	24312	20660	11010	76	930	<b>23280</b>	<b>22412</b>	<b>23280</b>	<b>22412</b>
	-----	RE54-3-3	3	550	31213	28722	25830	15420	77	940	----	<b>22820</b>	----	<b>22820</b>
60"	-----	RE54-5-3	5	660	37458	35238	32893	26538	80	960	----	<b>22992</b>	----	<b>22992</b>
	RE60-1	RE60-1-3	1	250	23090	19161	12850	----	76	1150	<b>23422</b>	<b>23117</b>	<b>23422</b>	<b>23117</b>
	RE60-1 1/2	RE60-1 1/2-3	1.5	340	28068	23283	15624	8000	77	1150	<b>24322</b>	<b>23809</b>	<b>24322</b>	<b>23809</b>
	RE60-2	RE60-2-3	2	390	32200	26710	17924	9380	78	1200	<b>24854</b>	<b>23985</b>	<b>24854</b>	<b>23985</b>
	-----	RE60-3-3	3	450	37183	32356	25324	15013	84	1220	----	<b>24405</b>	----	<b>24405</b>
	-----	RE60-5-3	5	540	44600	41232	35819	23237	86	1240	----	<b>24556</b>	----	<b>24556</b>
-----	RE60-7 1/2-3	7.5	620	50184	47603	43981	32880	89	1285	----	<b>25422</b>	----	<b>25422</b>	

Note: Products listed in this section are custom built and subject to 100% cancellation/restocking charges

# Direct Drive Roof Ventilators



## Features

- Cast Aluminum blades on most models
- Totally enclosed and explosion proof motors
- 1-Phase motors are field convertible 115V/230V
- 3-Phase motors are field convertible 230V/460V
- Motors are set to lower voltage at the factory unless a request is made at time of order to set them to the higher voltage
- Explosion proof motors are Class 1, Div 1, Group D and Class 2, Div 1, Groups F & G
- Wind band is 18 gauge galvanized steel
- Rubber shim under dampers for better seal
- Size of roof opening to be 6" larger than fan size
- Some models available with low R.P.M. motor for quieter operation
- 1 year limited warranty

**WARNING:** This product can expose you to chemicals including nickel which is known to the State of California to cause cancer, and chromium, which is known to the State of California to cause birth defects and/or reproductive harm. For more information go to [www.P65Warnings.ca.gov](http://www.P65Warnings.ca.gov).

## Options

- Protective coating
- Prefabricated curbs
- Disconnect switch

## Standard Models

BLADE SIZE	1-PHASE 115/230V	3-PHASE 208/230/460v	HP	RPM	C.F.M - STATIC PRESSURE				Db's @ 10'	WT. (LBS)	LIST			
					MFG MODEL NUMBER						TEC		EXP*	
					0"	1/8"	1/4"	1/2"			1 PH	3 PH	1 PH	3 PH
18"	UED18-1/4	UED18-1/4-3	1/4	1140	2570	2263	1673	854	66	170	7149	7179	7633	8047
	UED18-1/3	UED18-1/3-3	1/3	1725	3375	3000	2600	1400	75	175	6615	6602	7644	7865
	UED18-1/2	UED18-1/2-3	1/2	1725	4133	3938	3724	3132	76	180	6792	6765	7833	8026
	UED18-1	UED18-1-3	1	1725	4600	4375	4080	3000	77	190	7572	7408	8629	8712
24"	UED24-1/4	UED24-1/4-3	1/4	1725	5200	4200	2820	----	75	240	7397	7432	7884	8297
	UED24-3/4	UED24-3/4-3	3/4	1140	6900	6450	6265	3300	76	260	8955	8591	9982	9902
	UED24-1	UED24-1-3	1	1725	7425	7000	6350	5000	83	280	8075	7934	9144	9245
	-----	UED24-3-3	3	1725	10500	9800	9500	8700	85	295	-----	8519	-----	10125
30"	UED30-3/4	UED30-3/4-3	3/4	1140	10440	9750	8750	6000	79	310	9375	8759	10407	10338
	-----	UED30-1-3	1	870	10800	10100	9100	6360	74	330	-----	10183	-----	-----
	UED30-1 1/2	UED30-1 1/2-3	1.5	1140	10410	9686	8834	6420	81	325	12968	9601	-----	10931
	UED30-2	UED30-2-3	2	1140	14000	13750	12900	10450	82	335	15633	9833	-----	11254
	-----	UED30-3-3	3	1725	16000	15350	14700	12900	89	335	-----	8976	-----	10589
36"	UED36-2	UED36-2-3	2	1140	17620	16500	15200	12300	84	430	17390	11648	-----	13071
	-----	UED36-3-3	3	1140	20500	19500	18500	15850	85	455	-----	12353	-----	14687
	-----	UED36-5-3	5	1140	22600	21700	20500	19000	87	465	-----	13185	-----	15816
42"	UED42-2	UED42-2-3	2	1140	17964	17277	15326	12351	88	500	18571	12855	-----	14273
	-----	UED42-5-3	5	1140	28970	27960	26840	24200	89	500	-----	14331	-----	16957
48"	-----	UED48-3-3	3	1140	28600	26500	24400	20000	92	550	-----	15470	-----	17039
	-----	UED48-5-3	5	870	33000	31500	29750	25300	86	665	-----	18468	-----	-----
	-----	UED48-7 1/2-3	7.5	1140	37000	35100	32800	28000	94	740	-----	18552	-----	21900
	-----	UED48-10-3	10	1140	41000	39200	38300	35400	95	875	-----	19529	-----	23092
60"	-----	UED60-5-3	5	870	45200	41500	37000	26000	90	940	-----	24406	-----	-----
	-----	UED60-7 1/2-3	7.5	870	47000	45500	43600	38700	92	950	-----	26109	-----	-----

\*Not all EXP motors are 208v capable

Note: Products listed in this section are custom built and subject to 100% cancellation/restocking charges

## Dimensions

SIZE	MINIMUM ROOF HOLE SIZE (SQUARE)	WIND BAND OUTER DIMENSION	ROOF CURB OUTER DIMENSION (SQUARE)	WIND BAND HEIGHT
18"	28"	24"	33"	16"
24"	34"	30"	39"	19"
30"	40"	36"	45"	22"
36"	46"	42"	51"	25"
42"	52"	48"	57"	27"
48"	58"	54"	63"	30"
60"	70"	66"	75"	42"

# Belt Drive Roof Ventilators

## Features

- Standard blades are heavy gauge steel
- Totally enclosed motors
- 1-Phase motors are field convertible 115V/230V
- 3-Phase motors are field convertible 230V/460V
- Motors are set to lower voltage at factory unless a request is made at time of order to set them to the higher voltage
- Wind band is 18-gauge galvanized steel
- Galvanized steel butterfly damper with rubber stops and seals
- Size of the roof opening to be 6" larger than fan size (Wind Band O.D.) dimension
- 1 year limited warranty



**WARNING:** This product can expose you to chemicals including nickel which is known to the State of California to cause cancer, and chromium, which is known to the State of California to cause birth defects and/or reproductive harm. For more information go to [www.P65Warnings.ca.gov](http://www.P65Warnings.ca.gov).

## Options

- Protective coating
- Prefabricated curbs
- Disconnect switch

## Standard Models

BLADE SIZE	1-PHASE 115/230V	3-PHASE 208/230/460v	HP	RPM	C.F.M - STATIC PRESSURE				Db's @ 10'	WT. (LBS)	LIST	
					MFG MODEL NUMBER						TEC	
	0"	1/8"	1/4"	1/2"	1 PH	3 PH						
24"	UEB24-1/3	UEB24-1/3-3	1/3	780	4900	4222	2807	800	64	300	<b>8036</b>	<b>8026</b>
	UEB24-1/2	UEB24-1/2-3	1/2	980	6219	5716	5661	2600	66	305	<b>8278</b>	<b>8249</b>
	UEB24-3/4	UEB24-3/4-3	3/4	1140	7090	6648	6144	4413	71	310	<b>8560</b>	<b>8411</b>
30"	UEB30-1/2	UEB30-1/2-3	1/2	640	8507	7170	4486	1373	64	350	<b>8663</b>	<b>8629</b>
	UEB30-3/4	UEB30-3/4-3	3/4	770	10235	9192	7657	3833	66	360	<b>9126</b>	<b>8963</b>
	UEB30-1	UEB30-1-3	1	975	10668	9959	8626	5184	70	370	<b>9721</b>	<b>9628</b>
36"	UEB36-1/2	UEB36-1/2-3	1/2	530	10500	8821	5985	2084	66	360	<b>10235</b>	<b>10206</b>
	UEB36-3/4	UEB36-3/4-3	3/4	605	11985	10583	8563	4017	68	370	<b>10810</b>	<b>10649</b>
	UEB36-1	UEB36-1-3	1	665	13174	11932	10299	5729	70	390	<b>11212</b>	<b>11170</b>
	UEB36-1 1/2	UEB36-1 1/2-3	1.5	720	13660	12012	9579	5000	72	395	<b>11674</b>	<b>11489</b>
42"	UEB42-3/4	UEB42-3/4-3	3/4	435	14040	11530	7633	3311	67	455	<b>11780</b>	<b>11618</b>
	UEB42-1	UEB42-1-3	1	490	15429	13194	10438	4668	69	465	<b>12275</b>	<b>12255</b>
	UEB42-1 1/2	UEB42-1 1/2-3	1.5	550	17420	15421	13117	7289	71	470	<b>13002</b>	<b>12809</b>
	UEB42-2	UEB42-2-3	2	725	20653	19128	17503	11319	74	485	<b>13930</b>	<b>13415</b>
	-----	UEB42-3-3	3	830	23645	22296	20984	17290	79	495	----	<b>13606</b>
48"	UEB48-3/4	UEB48-3/4-3	3/4	370	17339	13700	7389	2244	70	505	<b>13624</b>	<b>13473</b>
	UEB48-1	UEB48-1-3	1	410	19188	16078	10903	4037	71	520	<b>14038</b>	<b>13939</b>
	UEB48-1 1/2	UEB48-1 1/2-3	1.5	465	21731	19010	14991	7081	72	535	<b>14280</b>	<b>14128</b>
	UEB48-2	UEB48-2-3	2	520	24274	21943	19080	10125	74	545	<b>15618</b>	<b>15140</b>
	-----	UEB48-3-3	3	680	28150	25683	23615	16930	80	560	----	<b>15392</b>
54"	UEB54-1	UEB54-1-3	1	410	23130	20588	17500	9600	73	870	<b>19058</b>	<b>18895</b>
	UEB54-1 1/2	UEB54-1 1/2-3	1.5	450	25400	22600	19300	10316	75	880	<b>19488</b>	<b>19320</b>
	UEB54-2	UEB54-2-3	2	480	27200	24312	20660	11010	76	890	<b>20034</b>	<b>19589</b>
	-----	UEB54-3-3	3	550	31213	28722	25830	15420	80	900	----	<b>20288</b>
	-----	UEB54-5-3	5	660	37458	35238	32843	26538	82	920	----	<b>20509</b>
60"	UEB60-1 1/2	UEB60-1 1/2-3	1.5	340	28068	23203	15624	8000	78	940	<b>20741</b>	<b>20569</b>
	UEB60-2	UEB60-2-3	2	390	32200	26710	17924	9380	80	960	<b>21196</b>	<b>20761</b>
	-----	UEB60-3-3	3	450	37183	32356	25324	15013	84	985	----	<b>21838</b>
	-----	UEB60-5-3	5	540	44600	41232	35819	23237	86	1000	----	<b>22042</b>

Note: Products listed in this section are custom built and subject to 100% cancellation/restocking charges

## Dimensions

SIZE	MINIMUM ROOF HOLE SIZE (SQUARE)	WIND BAND OUTER DIMENSION	ROOF CURB OUTER DIMENSION (SQUARE)	WIND BAND HEIGHT
24"	34"	30"	39"	19"
30"	40"	36"	45"	22"
36"	46"	42"	51"	25"
42"	52"	48"	57"	27"
48"	58"	54"	63"	30"
54"	64"	60"	69"	36"
60"	70"	66"	75"	42"

# Tubeaxial Direct Drive Duct Fans



## Features

- Totally enclosed and explosion proof motors
- 1-Phase motors are field convertible 115V/230V
- 3-Phase motors are field convertible 230V/460V
- Motors are set to lower voltage at the factory unless a request is made at time of order to set them to the higher voltage
- Explosion proof motors are Class 1, Div 1, Group D and Class 2, Div 1, Groups F & G
- 14 gauge steel drum including mounting flanges
- Fan can be mounted to operate in any position
- Rugged cast aluminum blade, non-sparking
- 1 year limited warranty

## Dimensions

SIZE	HOUSING I.NNER DIM.	HOUSING O.U.T.E.R DIM.	BOLT HOLE C.E.N.T.E.R.S	HOUSING D.E.P.T.H
12"	12"	14"	13 1/8"	14"
18"	18"	20"	19 1/8"	14"
24"	24"	27"	25 3/4"	18"
27"	27"	30"	28 3/4"	18"
30"	30"	33"	31 3/4"	18"
34"	34"	37"	35 3/4"	18"
42"	42"	45"	43 9/16"	18"
48"	48"	51"	49 5/8"	18"

**⚠ WARNING:** This product can expose you to chemicals including nickel which is known to the State of California to cause cancer, and chromium, which is known to the State of California to cause birth defects and/or reproductive harm. For more information go to [www.P65Warnings.ca.gov](http://www.P65Warnings.ca.gov).

## Options

- Companion flanges
- Protective coating
- Fan guards
- Access doors

## Standard Models

BLADE SIZE	1-PHASE 115/230V		3-PHASE 230/460v		HP	RPM	BLADES	C.F.M - STATIC PRESSURE				Db's @ 10'	WT. (LBS)	LIST			
	MFG MODEL NUMBER							0" 1/4" 1/2" 3/4"						TEC		EXP	
	1 PH	3 PH	1 PH	3 PH				1 PH	3 PH	1 PH	3 PH						
12"	TXD12-1/4	TXD12-1/4-3	1/4	1725	4	1180	520	----	----	77	40	<b>2558</b>	<b>2532</b>	<b>3183</b>	<b>3290</b>		
	TXD12-1/2	TXD12-1/2-3	1/2	3450	4	1875	1400	1250	1100	82	45	<b>2632</b>	<b>2622</b>	<b>3555</b>	<b>3954</b>		
	TXD12-3/4	TXD12-3/4-3	3/4	3450	6	2044	1920	1650	1500	83	45	<b>2728</b>	<b>2728</b>	<b>3795</b>	<b>4087</b>		
18"	TXD18-1/4	TXD18-1/4-3	1/4	1725	4	3450	2500	----	----	74	55	<b>3023</b>	<b>2994</b>	<b>3642</b>	<b>3747</b>		
	TXD18-1/3	TXD18-1/3-3	1/3	1725	6	3375	2600	1400	----	75	65	<b>3171</b>	<b>3198</b>	<b>3979</b>	<b>4204</b>		
	TXD18-1/2	TXD18-1/2-3	1/2	1725	6	4150	3150	1700	----	77	65	<b>3295</b>	<b>3314</b>	<b>4257</b>	<b>4158</b>		
	TXD18-1	TXD18-1-3	1	1725	6	4600	4080	3000	2100	80	70	<b>3716</b>	<b>3535</b>	<b>4636</b>	<b>4717</b>		
24"	TXD24-1/4	TXD24-1/4-3	1/4	1725	2	5200	2820	----	----	80	95	<b>3314</b>	<b>3295</b>	<b>3937</b>	<b>3961</b>		
	TXD24-1/3	TXD24-1/3-3	1/3	1140	6	4975	4250	2850	----	74	110	<b>3988</b>	<b>4052</b>	<b>5441</b>	<b>5410</b>		
	TXD24-1/2	TXD24-1/2-3	1/2	1725	4	6510	5200	3100	1800	80	115	<b>3663</b>	<b>3679</b>	<b>4620</b>	<b>4522</b>		
	TXD24-3/4	TXD24-3/4-3	3/4	1140	6	6900	6265	3300	----	74	125	<b>4945</b>	<b>4400</b>	<b>5730</b>	<b>5550</b>		
	TXD24-1	TXD24-1-3	1	1725	6	7425	6350	5000	3300	82	120	<b>4059</b>	<b>3874</b>	<b>4984</b>	<b>5066</b>		
	TXD24-2	TXD24-2-3	2	1725	6	9525	8810	7980	6960	84	120	<b>4913</b>	<b>4184</b>	<b>6845</b>	<b>5558</b>		
	-----	TXD24-3-3	3	1725	6	10500	9500	8700	7800	86	130	----	<b>4548</b>	----	<b>6013</b>		
27"	TXD27-1/2	TXD27-1/2-3	1/2	1725	4	7550	6000	4000	2000	86	125	<b>4000</b>	<b>4007</b>	<b>4945</b>	<b>4848</b>		
	TXD27-1	TXD27-1-3	1	1725	4	9600	8400	7050	4800	86	155	<b>4333</b>	<b>4158</b>	<b>5258</b>	<b>5338</b>		
	TXD27-2	TXD27-2-3	2	1725	6	11500	10700	9300	8000	86	165	<b>5284</b>	<b>4557</b>	<b>7217</b>	<b>5933</b>		
30"	TXD30-1/2	TXD30-1/2-3	1/2	1725	4	8980	6300	4350	2300	86	130	<b>4158</b>	<b>4175</b>	<b>5119</b>	<b>5019</b>		
	TXD30-3/4	TXD30-3/4-3	3/4	1140	6	10440	8750	6000	----	80	150	<b>5590</b>	<b>5036</b>	<b>6377</b>	<b>6214</b>		
	TXD30-2	TXD30-2-3	2	1725	6	12000	10450	8700	6000	89	155	<b>5436</b>	<b>4707</b>	<b>7370</b>	<b>6081</b>		
	-----	TXD30-3-3	3	1725	6	16000	14700	12900	10200	89	175	----	<b>4922</b>	----	<b>6394</b>		
34"	TXD34-1 1/2	TXD34-1 1/2-3	1.5	1725	4	13350	10000	7300	----	88	175	<b>5590</b>	<b>5355</b>	<b>8124</b>	<b>6726</b>		
	TXD34-2	TXD34-2-3	2	1725	4	14850	12100	8800	4000	89	200	<b>6188</b>	<b>5463</b>	<b>8124</b>	<b>6840</b>		
	-----	TXD34-3-3	3	1140	3	19300	17230	14800	11614	86	250	----	<b>7074</b>	----	<b>8933</b>		
	-----	TXD34-5-3	5	1725	6	21000	18900	17500	14850	91	220	----	<b>5815</b>	----	<b>7436</b>		
36"	TXD36-2	TXD36-2-3	2	1140	6	17620	15200	12300	8500	84	210	----	<b>6065</b>	----	<b>7648</b>		
	-----	TXD36-3-3	3	1725	4	18500	15700	13900	11500	89	230	----	<b>6752</b>	----	<b>8603</b>		
42"	-----	TXD42-1-3	1	870	4	15800	13480	5800	900	81	270	----	<b>7336</b>	----	----		
	TXD42-2	TXD42-2-3	2	1140	4	17964	15326	12351	7600	87	260	----	<b>6909</b>	----	<b>8479</b>		
	-----	TXD42-3-3	3	1140	4	24500	23000	19650	14000	87	260	----	<b>7741</b>	----	<b>9600</b>		
	-----	TXD42-5-3	5	1140	4	28970	26840	24200	19500	87	300	----	<b>8028</b>	----	<b>10682</b>		
48"	-----	TXD48-3-3	3	1140	4	28600	24400	20000	15900	94	290	----	<b>9653</b>	----	<b>11507</b>		
	-----	TXD48-5-3	5	870	4	33000	29750	25300	18000	86	500	----	<b>12272</b>	----	----		

## Duct Fan Guards

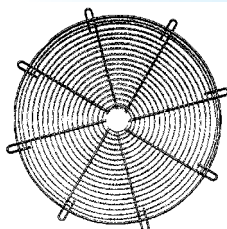

## Features

- Enamel finish
- Can be used as front or rear guards. (Rear guard for TXD models must be ordered with fan)

## Standard Models

FAN SIZE	MFG MODEL	LIST	FAN SIZE	MFG MODEL	LIST
12"	TXG-12	<b>220</b>	30"	TXG-30	<b>299</b>
15"	TXG-15	<b>220</b>	34"	TXG-34	<b>380</b>
18"	TXG-18	<b>220</b>	36"	TXG-36	<b>393</b>
24"	TXG-24	<b>240</b>	42"	TXG-42	<b>431</b>
27"	TXG-27	<b>299</b>	48"	TXG-48	<b>562</b>

Note: Products listed in this section are custom built and subject to 100% cancellation/restocking charges



# Tubeaxial Belt Drive Duct Fans

## Features

- Eliminates fumes and vapors from paint spray booths and other hazardous areas
- Totally enclosed and explosion proof motors
- 1-Phase motors are field convertible 115V/230V
- 3-Phase motors are field convertible 230V/460V
- Motors are set to lower voltage at the factory unless a request is made at time of order to set them to the higher voltage
- Explosion proof motors are Class 1, Div 1, Group D and Class 2, Div 1, Groups F & G
- Recommended for most paint spray applications because motor is out of air
- 14 gauge steel drum including mounting flanges at each end
- Completely enclosed belt and ball bearing housing
- Adjustable motor base for proper belt tension
- Rugged cast aluminum blade, non-sparking
- Fan can be mounted to operate in any position
- 1 year limited warranty



**⚠ WARNING:** This product can expose you to chemicals including nickel which is known to the State of California to cause cancer, and chromium, which is known to the State of California to cause birth defects and/or reproductive harm. For more information go to [www.P65Warnings.ca.gov](http://www.P65Warnings.ca.gov).

## Options

- Companion flanges
- Protective coating
- Access doors
- Belt guards
- Motor covers
- Fan guards

## Standard Models

BLADE SIZE	1-PHASE 115/230V-60Hz MFG MODEL NUMBER	3-PHASE 230/460V-60Hz MFG MODEL NUMBER	HP	RPM	BLADES	C.F.M - STATIC PRESSURE				Db's @10'	WT (LBS)	LIST			
						0"	1/4"	1/2"	3/4"			TEC		EXP	
												1 PH	3 PH	1 PH	3 PH
12"	TXB12-1/4	TXB12-1/4-3	1/4	2625	4	1444	1033	380	----	77	62	3449	3430	4098	4205
	TXB12-1/3	TXB12-1/3-3	1/3	2875	4	1586	1135	415	----	78	65	3518	3556	4363	4585
	TXB12-1/2	TXB12-1/2-3	1/2	3450	4	1875	1400	1250	1100	83	65	3518	3518	4335	4702
	TXB12-3/4	TXB12-3/4-3	3/4	3450	6	2044	1920	1650	1500	83	67	3831	3831	4631	4968
15"	TXB15-1/4	TXB15-1/4-3	1/4	2000	6	2600	1700	----	----	77	67	3796	3778	4441	4549
	TXB15-1/3	TXB15-1/3-3	1/3	2200	6	2950	2100	1000	----	78	69	3910	3940	4746	4968
	TXB15-1/2	TXB15-1/2-3	1/2	1890	6	3350	2650	1500	----	76	75	4026	4044	5021	4916
	TXB15-3/4	TXB15-3/4-3	3/4	2200	6	3900	3400	2700	1150	78	85	4380	4150	5376	5128
18"	TXB18-1/4	TXB18-1/4-3	1/4	1600	6	3050	2000	----	----	76	80	4008	3992	4655	4762
	TXB18-1/3	TXB18-1/3-3	1/3	1725	6	3375	2600	1400	----	77	85	4053	4114	4924	5147
	TXB18-1/2	TXB18-1/2-3	1/2	1890	6	3850	3100	2000	----	78	95	4205	4223	5199	5093
	TXB18-1	TXB18-1-3	1	1725	6	4600	4080	3000	2100	77	105	4797	4575	5710	5803
24"	TXB18-1 1/2	TXB18-1 1/2-3	1.5	1990	6	5350	4830	3950	3000	80	105	5021	4787	7644	6205
	TXB24-1/2	TXB24-1/2-3	1/2	1298	6	5643	4826	3500	----	78	120	4560	4575	5551	5445
	TXB24-3/4	TXB24-3/4-3	3/4	1600	6	6906	5900	4650	2750	80	130	4979	4746	5969	5722
	TXB24-1	TXB24-1-3	1	1725	6	7425	6350	5000	3300	84	140	5021	4825	5969	6061
27"	TXB24-1 1/2	TXB24-1 1/2-3	1.5	1540	6	8200	7650	6850	5500	81	145	6103	5872	8714	7284
	TXB24-2	TXB24-2-3	2	1600	6	9760	8830	8090	7000	82	170	6940	6192	8925	7602
	-----	TXB24-3-3	3	1725	6	10500	9500	8700	7800	86	190	-----	6387	-----	7909
	TXB27-3/4	TXB27-3/4-3	3/4	1250	6	8330	7550	6500	4650	78	150	6097	5855	7080	6841
30"	TXB27-1	TXB27-1-3	1	1400	6	9400	8480	7300	5200	82	155	6131	5942	7080	7160
	TXB27-1 1/2	TXB27-1 1/2-3	1.5	1600	6	10700	9700	8375	6000	84	170	6410	6174	9016	7575
	TXB27-2	TXB27-2-3	2	1350	6	11500	10700	9300	8000	81	210	7145	6395	9142	7818
	TXB30-1/2	TXB30-1/2-3	1/2	1140	4	8900	6660	2300	----	79	140	5763	5796	6760	6663
34"	TXB30-1	TXB30-1-3	1	1298	6	9867	7980	4120	----	82	150	6395	6210	7345	7438
	TXB30-1 1/2	TXB30-1 1/2-3	1.5	1035	6	11100	9700	7500	3500	78	165	6672	6439	9285	7854
	TXB30-2	TXB30-2-3	2	1176	6	12100	11000	9322	6700	81	215	7301	6557	9300	7977
	-----	TXB30-3-3	3	1350	6	13480	12498	11465	10380	84	215	-----	6992	-----	8500
42"	-----	TXB30-5-3	5	1650	6	16440	15242	13982	12659	88	230	-----	7071	-----	8725
	TXB34-1 1/2	TXB34-1 1/2-3	1.5	1170	6	13695	11100	6000	1015	82	190	7712	7484	10325	8885
	TXB34-2	TXB34-2-3	2	1027	6	14657	12590	10000	8000	81	240	8591	7844	10580	9264
	-----	TXB34-3-3	3	1175	6	17580	15896	14095	12000	85	260	-----	8049	-----	9559
48"	-----	TXB34-5-3	5	1416	6	20500	19000	17500	16000	88	305	-----	8102	-----	9772
	TXB42-1 1/2	TXB42-1 1/2-3	1.5	750	4	18960	14662	7200	----	78	250	9142	9185	12029	10589
	TXB42-2	TXB42-2-3	2	820	4	20700	17002	11400	4000	80	260	9786	9337	12083	10750
	-----	TXB42-3-3	3	890	4	23700	20200	16970	9950	82	260	-----	9530	-----	11039
48"	-----	TXB42-5-3	5	850	6	26900	24403	22250	18400	82	270	-----	10029	-----	11691
	-----	TXB48-5-3	5	800	6	33000	29000	25600	20000	85	375	-----	14866	-----	16533
48"	-----	TXB48-7 1/2-3	7.5	900	6	37000	34500	31000	27000	87	520	-----	15791	-----	18592

## Dimensions

SIZE	HOUSING INNER DIMENSION	HOUSING OUTER DIMENSION	BOLT HOLE CENTERS	HOUSING DEPTH
12"	12"	14"	13 1/8"	12"
15"	15"	17"	16 1/8"	12"
18"	18"	20"	19 1/8"	12"
24"	24"	27"	25 3/4"	12" & 16"
27"	27"	30"	28 3/4"	16"
30"	30"	33"	31 3/4"	16"
34"	34"	37"	35 3/4"	16"
42"	42"	45"	43 9/16"	18"
48"	48"	51"	49 5/8"	24"

Note: Products listed in this section are custom built and subject to 100% cancellation/restocking charges

## Belt Drive Wholehouse Fans



**WARNING:** This product can expose you to chemicals including nickel which is known to the State of California to cause cancer, and chromium, which is known to the State of California to cause birth defects and/or reproductive harm. For more information go to [www.P65Warnings.ca.gov](http://www.P65Warnings.ca.gov).



### Features

- 120V 1-phase, 2-speed motor
- Shutters automatically open when fan is turned on and close tightly when fan is turned off.
- Made in the U.S.A.

### FAN DIMENSIONS

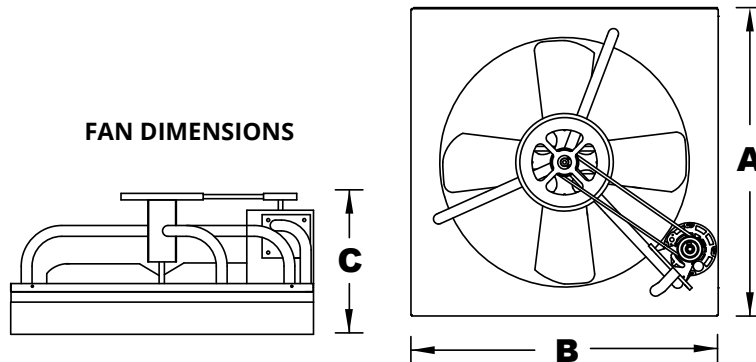

### Standard Models

MFG CATALOG NUMBER	MFG MODEL NUMBER	SIZE	SPEED	MOTOR HP	CFM @ .1 IN. H2O PRESSURE DROP w/SHUTTER	FAN SPEED RPM	FAN MOUNTING DIMENSIONS (IN)			EXHAUST SQ. FT. REQ'D	AMPS	WT. (LBS)	LIST
							A	B	C				
07936202	BD24-2-WHS	24"	2	1/3	4500/2700	612/410	28	29.5	14.5	7	5.7/4.8	40	<b>1237</b>
07936302	BD30-2-WHS	30"	2	1/3	7600/5800	520/350	34	35.5	14.5	9	6.9/5.5	50	<b>1329</b>
07936402	BD36-2-WHS	36"	2	1/3	9675/6400	395/265	40	41.5	14.5	12	6.3/3.1	64	<b>1461</b>

### Ceiling Shutters

MFG CATALOG NUMBER	MFG MODEL NUMBER	FIT HOLE SIZE (I.D.)	OUTSIDE SIZE (O.D.)	FAN SIZE	WT. (LBS)	LIST
07944802	CS-10-W	26X26	28X28	24"	8	<b>220</b>
07944602	CS-13-W	32X34	34X36	30"	10	<b>229</b>
07945302	CS-14-W	34X34	36X36	30"	10	<b>241</b>
07944702	CS-18-W	32X43	34X45	36"	11	<b>260</b>
07945202	CS-19-W	34X43	36X45	36"	11	<b>282</b>

### Control Options

MFG CATALOG NUMBER	MFG MODEL NUMBER	DESCRIPTION	WT. (LBS)	LIST
07927002	2-SW	2 Speed wall switch & plate	1	<b>61</b>
05000802	1A22-7	SP close on rise (Attic Thermostat) (80°-130°F)	1	<b>77</b>

"Joist out style" (For replacement only)

# Loading Dock Lights - Shipped in (1) One Carton



DKL-40VA-A



Flexible elastomer arm moves when hit and then returns light to original position

DKL-25-FLX



**LED 30-Watt**  
DKLED-40-30W

**⚠ WARNING:** This product can expose you to chemicals including nickel which is known to the State of California to cause cancer, and chromium, which is known to the State of California to cause birth defects and/or reproductive harm. For more information go to [www.P65Warnings.ca.gov](http://www.P65Warnings.ca.gov).

## Product Features

- Chip resistant safety yellow & black powder coated finish for high visibility and durability
- 5' long 18/3 SJT, 120V cordset with NEMA 15-5 grounded plug
- On/Off switch & wire guard included on each light head
- 1-1/2" square, 11-gauge, steel tubing
- 3" x 5" x 3/16" mounting plate attached with (4) 3/8" bolts (not supplied)
- VA & DKLED models have vertical adjustment bracket allowing outer arm to adjust from 300° horizontally and 210° vertically
- All light heads will swivel 300°
- VA Models include an embedded electrical outlet for direct plug connection from the light head fixture and shipped fully-assembled
- DKLED units contain a die-cast aluminum light head with adjustable knobs, built-in on/off switch, and maintains an IP65 rating suitable for wet locations
- DKLED units use a 20° custom beam angle and 12 individual high-intensity LED emitters generating a neutral white color; with a CCT measuring 4,000K DKLED units provide a minimum life of 50,000 hours and offers a 5-year warranty, including CE & RoHS Certificates
- Designed for loading dock and work station environments
- ETL C/US Listed for indoor applications only, except QH models are semi-protected outdoor and DKLED models have IP65 rating suitable for wet location areas

## Standard Models (120V)

MFG CATALOG NUMBER	MFG MODEL NUMBER	ARM LENGTH	# OF ARMS	MAX WATTS	WT. (LBS)	LIST
<b>NO BULB</b>						
04466502	DKL-40VA-A	40"	2	Maximum 300	14	<b>310</b>
04466602	DKL-60VA-A	60"	2		17	<b>373</b>
03854001	DKL-25-FLX	25"	1		17	<b>312</b>
<b>LED - 3,300 Lumens, 4,000K CCT, 50,000-hour Avg. Bulb Life</b>						
04922802	DKLED-40-30W	40"	2	30	13	<b>479</b>
04922902	DKLED-42-30W	42"	3		14	<b>504</b>



**Spot task lighting WHEN & WHERE you need it!**



**LED 30-Watt**  
DKLED-42-30W



# Loading Dock Lights - Modular (shipped in multiple cartons)

## Modular Lights

DKL-LED-30W-SP



DKL-INC



DKLED-30W-WP



DKL-LED37



### Features

- 14" long, 18/3 conductor cord plugs into electrical junction box on arm
- On/off switch & wire guard included with each light head
- Bulb included with all light heads except DKL-INC
- Imported to TPI specifications.
- DKL-LED-37 is compliant with ROHS 2 Directive
- (2011/65/EU), that of which includes the application exemptions outlined in Annex III of the directive.

**WARNING:** This product can expose you to chemicals including nickel which is known to the State of California to cause cancer, and chromium, which is known to the State of California to cause birth defects and/or reproductive harm. For more information go to [www.P65Warnings.ca.gov](http://www.P65Warnings.ca.gov).

## Standard Models

MFG CATALOG NUMBER	MFG MODEL NUMBER	LIGHT HEAD TYPE	MAX WATTS	MAX LUMENS	AVE. BULB LIFE (HRS)	WT. (LBS)	LIST
04465602	DKL-INC	No Bulb Included	300	3,700	2,000	5	<b>128</b>
04881302	DKL-LED-37	LED	37	2,373	>30,000	5	<b>508</b>
04923002	DKLED-30W-WP	LED w/ Pin Connector Plug	30	3,300	50,000	7	<b>362</b>
04923102	DKLED-30W-SP	LED w/ Grounded Plug	30	3,300	50,000	7	<b>362</b>

## Mounting Arms



DKL-40VA-ARM



60-LDA



24-LDA



The outer arm on 40VA & 60VA arms will swing 300° in horizontal plane & 210° in vertical plane

**WARNING:** This product can expose you to chemicals including nickel which is known to the State of California to cause cancer, and chromium, which is known to the State of California to cause birth defects and/or reproductive harm. For more information go to [www.P65Warnings.ca.gov](http://www.P65Warnings.ca.gov).

### Features

- 1 1/2" square, 11 gauge, steel tubing
- 3" x 5" x 3/16" mounting plate attaches
- with (4) 3/8" bolts
- 5' long, 18/3 SJTW conductor cord and
- NEMA 5-15 grounded plug
- Made in U.S.A.

## Standard Models

MFG CATALOG NUMBER	MFG MODEL NUMBER	ARM LENGTH	TOTAL # OF ARMS	WT. (LBS)	LIST
04465402	DKL-40VA-ARM	40"	2	18	<b>194</b>
04465502	DKL-60VA-ARM	60"	2	24	<b>245</b>
04465302	24-LDA	24"	1	11	<b>152</b>
04466102	40-LDA**	40"	3	18	<b>260</b>
04466202	60-LDA**	60"	3	24	<b>302</b>

\*\*Indicates heavy duty dock arms (horizontal swing only, no vertical movement)

## Loading Dock Arm Fan



### Features

- 18" high velocity circulator, with 3 speed, 1/8 HP, 115V,
- 1 phase permanently lubricated, totally enclosed, PSC motor
- Modular fan plugs into electrical outlet on arm
- Coated steel guards and aluminum blades
- Imported to TPI specifications

**WARNING:** This product can expose you to chemicals including nickel which is known to the State of California to cause cancer, and chromium, which is known to the State of California to cause birth defects and/or reproductive harm. For more information go to [www.P65Warnings.ca.gov](http://www.P65Warnings.ca.gov).

## Standard Models

MFG CATALOG NUMBER	MFG MODEL NUMBER	CFM			VELOCITY PROFILE MAX. CFM	AMPS HIGH	WT. (LBS)	LIST
		HIGH	MED	LOW				
07971802	LDF-18-TE	1800	1500	1300	2900	2.2	20	<b>308</b>

Note: Must be used with LDA (Heavy Duty) mounting arms

# Machine Tool Lights

## Water Resistant Fluorescent or LED Tube Lights



29-LED



23-TLP-24VDC



21-LED

### Features

- All tube lights come standard with a durable, lightweight, economical, shatter-resistant polycarbonate tube housing
- Stainless steel mounting brackets (2), fasteners and threaded conduit fitting included with all models
- LEDTLP Models are ETL C/US Listed for NEMA Type 13 applications - oil / water / coolant spray areas (not submersible) and dusty atmospheres
- LED Models operate at 120V and include an 8' long, 18/3 SJTOW cord with NEMA 5-15 grounded plug
- LED Models comply with part-15 of the FCC rule
- Model 21-LEDTLP-120-16 includes an aluminum enclosure with on/off power switch
- Model 21-LED generates 100 Watts of an incandescent light output equivalent, but only consumes 16 Watts of power; Model 29-LED generates 150 Watts, using only 26 Watts of power.
- 23-TLP-24VDC uses a fluorescent bulb and operates at low voltage of 24V DC, includes on board ballast and 2' long lead wires for direct connection; unit is NOT ETL Listed
- All units are made in the U.S.A.

### Standard Models

MFG CATALOG NUMBER	MFG MODEL NUMBER	DESCRIPTION	WATTS	VOLTS	LUMENS	OVERALL LENGTH	TUBE MATERIAL	BALLAST INCLUDED	WT. (LBS)	LIST
04829302	23-TLP-24VDC**	Fluorescent, w/wire leads	18	24VDC	1250	23"	Polycarbonate	Yes	6	<b>633</b>
04891802	21-LEDTLP-120-16	LED, on/off switch enclosure & cordset	16	120V	1200	21"	Polycarbonate	No	4	<b>724</b>
04891902	29-LEDTLP-120-26	LED w/cordset	26	120V	2800	29"	Polycarbonate	No	3	<b>806</b>

### Accessories - Replacement Lamps

MFG CATALOG NUMBER	MFG MODEL NUMBER	DESCRIPTION	USED WITH	WT. (LBS)	LIST
3103300	TL-RB-18	Fluorescent Replacement Bulb, 18W, PL-L	23-TLP-24VDC	1	<b>96</b>

**WARNING:** This product can expose you to chemicals including nickel which is known to the State of California to cause cancer, and chromium, which is known to the State of California to cause birth defects and/or reproductive harm. For more information go to [www.P65Warnings.ca.gov](http://www.P65Warnings.ca.gov).



# Product Index Listing

45

INDEX

MODEL	PAGE	MODEL	PAGE	MODEL	PAGE	MODEL	PAGE
1A22-7	41	CACU 24-PO	8	CE 24-DV	25	CESM-30	32
2-SW	41	CACU 24-W	8	CE 30-D	24	CESM-36	32
21-LEDTLP-120-16	44	CACU 24-WO	8	CE 30-DS	23	CESM-42	32
29-LEDTLP-120-26	44	CACU 30-P	8	CE 30-DV	25	CESM-48	32
23-TLP-24VDC	44	CACU 30-P-HD	8	CE-24B	26	CESM-60	32
24-LDA	43	CACU 30-PO	8	CE-24B-3	26	CF-12	20
24-LDF-TE	21	CACU 30-PO-HD	8	CE-30B	26	CF-18	20
40-LDA	43	CACU 30-W	8	CE-30B-3	26	CF-20	20
40-LDF-TE	21	CACU 30-WO	8	CE-36B	26	CL-300	44
60-LDA	43	CAS - 18	16	CE-36B-3	26	CPB 30-D	9
60-LDF-TE	21	CAS - 48	16	CE-42B	26	CPB 36-B	9
ACH 20	3	CBT-24B	30	CE-42-B-3	26	CPB 36-D	9
ACH 20-O	3	CBT-24B-3	31	CE-48B	26	CPB 42-B	9
ACH 24	3	CBT-30B	31	CE-48-B-3	26	CPB 48-B	9
ACH 24-EX1	5	CBT-30B-3	31	CEFP-12	34	CPBS 24-DHV	9
ACH 24-EX3	5	CBT-36B	31	CEFP-16	34	CPBS 30-D	9
ACH 24-O	3	CBT-36B-3	31	CEFP-18	34	CS-10-W	41
ACH 24-TE3	5	CBT-42B	31	CEFP-20	34	CS-13-W	41
ACH 30-TE3	5	CBT-42B-3	31	CEFP-24	34	CS-14-W	41
ACH 30	3	CBT-48B	31	CEFP-30	34	CS-18-W	41
ACH 30-EX1	5	CBT-48B-3	31	CEFP-36	34	CS-19-W	41
ACH 30-EX3	5	CD-18	35	CEFP-42	34	DKL-25-FLX	42
ACH 30-O	3	CD-24	35	CEFP-48	34	DKL-40VA-A	42
ACM-C	6	CD-30	35	CEFP-60	34	DKL-40VA-ARM	43
ACM-I	6	CD-36	35	CES 12-HD	32	DKL-60VA-A	42
ACM-P	6	CD-42	35	CES 16-HD	32	DKL-60VA-ARM	43
ACM-PM	6	CD-48	35	CES 18-HD	32	DKL-INC	21, 43
ACM-S	6	CD-54	35	CES 20-HD	32	DKLED-30W-WP	43
ACM-W	6	CD-60	35	CES 24-HD	32	DKLED-30W-SP	43
ACM-WK	6	CE 10-D	24	CES 30-HD	32	DKLED-40-30W	42
ACU 20-P	4	CE 10-DS	23	CES 36-HD	32	DKLED-42-30W	42
ACU 20-PO	4	CE 10-DV	25	CES 42-HD	32	DKL-LED-37	43
ACU 20-W	4	CE 12-D	24	CES 48-HD	32	DKL-QH	21, 43
ACU 20-WO	4	CE 12-DS	23	CES 54-HD	32	DMKP1	34
ACU 24-P	4	CE 12-DV	25	CES 60-HD	33	DMKP2	35
ACU 24-PO	4	CE 14-D	25	CES-10G	24, 25	DR36	24
ACU 24-W	4	CE 14-DS	23	CES-12G	24, 25	E-56CF	22
ACU 24-WO	4	CE 14-DV	25	CES-14G	24, 25	E-60CF	22
ACU 30-P	4	CE 16-D	24	CES-16G	24, 25	E-60CFC	22
ACU 30-PO	4	CE 16-DS	23	CES-18G	24, 25	EHB24-1	30
ACU 30-W	4	CE 16-DV	25	CES-20G	24, 25	EHB24-1-3	30
ACU 30-WO	4	CE 18-D	24	CES-24	26	EHB24-1/2	30
BD24-2-WHS	41	CE 18-DS	23	CES-24G	24, 25	EHB24-1/2-3	30
BD30-2-WHS	41	CE 18-DV	25	CES-30	26	EHB24-1/4	30
BD36-2-WHS	41	CE 20-D	24	CES-30G	24, 25	EHB24-1/4-3	30
CACU 20-P	8	CE 20-DS	23	CES-36	26	EHB24-3/4	30
CACU 20-W	8	CE 20-DV	25	CES-42	26	EHB24-3/4-3	30
CACU 24-P	8	CE 24-D	24	CES-48	26	EHB30-1	30
		CE 24-DS	23	CESM-24	32	EHB30-1 1/2	30

MODEL	PAGE	MODEL	PAGE	MODEL	PAGE	MODEL	PAGE
EHB30-1 1/2-3	30	EHB60-1 1/2-3	30	EHD36-5-3	29	HV-2	15
EHB30-1-3	30	EHB60-1-3	30	EHD42-1-3	29	HV-3	15
EHB30-1/2	30	EHB60-2	30	EHD42-2	29	HV-4-18	15
EHB30-1/2-3	30	EHB60-2-3	30	EHD42-2-3	29	HV-4-24	15
EHB30-1/3	30	EHB60-3-3	30	EHD42-3-3	29	HV-4-30	15
EHB30-1/3-3	30	EHB60-5-3	30	EHD42-5-3	29	HV-5-18	15
EHB30-1/4	30	EHD12-1/4	29	EHD48-3-3	29	HV-5-24	15
EHB30-1/4-3	30	EHD12-1/4-3	29	EHD48-5-3	29	HV-5-30	15
EHB30-3/4	30	EHD16-1/4	29	EHD60-10-3	29	HV-6-18	15
EHB30-3/4-3	30	EHD16-1/4-3	29	EHD60-3-3	29	HV-6-24	15
EHB36-1	30	EHD18-1/2	29	EHD60-5-5	29	HV-6-30	15
EHB36-1 1/2	30	EHD18-1/2-3	29	EHD60-7 1/2-3	29	HV-7-DC-1	15
EHB36-1 1/2-3	30	EHD18-1/3	29	EMF-12	33	HV-7-DC-3	15
EHB36-1-3	30	EHD18-1/3-3	29	EMF-16	33	HV-8	15
EHB36-1/2	30	EHD20-1	29	EMF-20	33	HV18-120V	15
EHB36-1/2-3	30	EHD20-1-3	29	EMF-24	33	HV18-208/240V	15
EHB36-1/3	30	EHD20-1/2	29	EMF-30	33	HV18-277V	15
EHB36-1/3-3	30	EHD20-1/2-3	29	EMF-36	33	HV18-480V	15
EHB36-2	30	EHD20-1/4	29	EMF-42	33	HV24-120V	15
EHB36-2-3	30	EHD20-1/4-3	29	EMF-48	33	HV24-208/240V	15
EHB36-3/4	30	EHD24-1	29	EMF-60	3	HV24-277V	15
EHB36-3/4-3	30	EHD24-1-3	29	F-12-TE	18	HV24-480V	15
EHB42-1	30	EHD24-1/2	29	F-18-TE	18	HV30-120V	15
EHB42-1 1/2	30	EHD24-1/2-3	29	F-18H-TE	18	HV30-208/240V	15
EHB42-1 1/2-3	30	EHD24-1/3	29	F-24-TE	18	HV30-277V	15
EHB42-1-3	30	EHD24-1/3-3	29	F-24-TE-HV	18	HV30-480V	15
EHB42-1/2	30	EHD24-1/4	29	F-24H-TE	18	HV18-480V-3	15
EHB42-1/2-3	30	EHD24-1/4-3	29	FLS-18	34	HV24-480V-3	15
EHB42-1/3	30	EHD24-2	29	FLS-24	35	HV30-480V-3	15
EHB42-1/3-3	30	EHD24-2-3	29	FLS-30	35	IBG-12	33
EHB42-2	30	EHD24-3-3	29	FLS-36	35	IBG-16	33
EHB42-2-3	30	EHD24-3/4	29	FLS-42	35	IBG-18	33
EHB42-3-3	30	EHD24-3/4-3	29	FLS-48	35	IBG-20	33
EHB42-3/4	30	EHD30-1 1/2	29	FLS-54	35	IBG-24	33
EHB42-3/4-3	30	EHD30-1 1/2-3	29	FLS-60	35	IBG-30	33
EHB48-1	30	EHD30-1-3	29	HDH 24	2	IBG-36	33
EHB48-1 1/2	30	EHD30-1/2	29	HDH 24-G	3	IBG-42	33
EHB48-1 1/2-3	30	EHD30-1/2-3	29	HDH 24-GJR	3	IBG-48	33
EHB48-1-3	30	EHD30-1/3	29	HDH 24-JR	2	IBG-60	33
EHB48-1/2	30	EHD30-1/3-3	29	HDH 30	2	IE24-1	28
EHB48-1/2-3	30	EHD30-2	29	HDH 30-G	3	IE24-1-3	28
EHB48-2	30	EHD30-2-3	29	HDH 30-GJR	3	IE24-1/2	28
EHB48-2-3	30	EHD30-3-3	29	HDH 30-JR	2	IE24-1/2-3	28
EHB48-3-3	30	EHD30-3/4	29	HDH 36	3	IE24-1/3	28
EHB48-3/4	30	EHD30-3/4-3	29	HDM-C	6	IE24-1/3-3	28
EHB48-3/4-3	30	EHD36-1	29	HDM-I	6	IE24-3/4	28
EHB48-5-3	30	EHD36-1-3	29	HDM-P	6	IE24-3/4-3	28
EHB60-1	30	EHD36-2-3	29	HDM-W	6	IE30-1	28
EHB60-1 1/2	30	EHD36-3-3	29	HV-1	15	IE30-1-3	28

# Product Index Listing

47

INDEX

MODEL	PAGE	MODEL	PAGE	MODEL	PAGE	MODEL	PAGE
IE30-1/2	28	IED24-1	27	MCD48-7 1/2	16	RDS-24	35
IE30-1/2-3	28	IED24-1-3	27	MCD60-10	16	RDS-30	35
IE30-1/3	28	IED30-1	27	MCD60-15	16	RDS-36	35
IE30-1/3-3	28	IED30-1-3	27	MCD60-3	16	RDS-42	35
IE30-3/4	28	IED36-1 1/2	27	MCD60-5	16	RDS-48	35
IE30-3/4-3	28	IED36-1 1/2-3	27	MCD60-7 1/2	16	RDS-54	35
IE36-1	28	IED42-2-3	27	MK-1	32	RDS-60	35
IE36-1 1/2	28	IED48-3-3	27	MK-2	32	RE24-1	36
IE36-1 1/2-3	28	IHP 20-H-WD	5	MK-3	32	RE24-1-3	36
IE36-1-3	28	IHP 24-H	3	N-12	21	RE24-1/2	36
IE36-1/2	28	IHP 24-H-277	5	ODF-12	20	RE24-1/2-3	36
IE36-1/2-3	28	IHP 24-H-WD	5	ODF-16	20	RE24-1/4	36
IE36-1/3	28	IHP 30-H	3	OSF-16	20	RE24-1/4-3	36
IE36-1/3-3	28	IHP 30-H-277	5	PBX 30-D	10	RE24-3/4	36
IE36-2	28	IHP 30-H-WD	5	PBX 36-B	11	RE24-3/4-3	36
IE36-2-3	28	KBWC-110K	22	PB 36-B-3	11	RE30-1	36
IE36-3/4	28	KBWC-155K	22	PB 36-B-HL	11	RE30-1 1/2	36
IE36-3/4-3	28	LDF-18-TE	21, 43	PBX 36-D	10	RE30-1 1/2-3	36
IE42-1	28	MB 24-DF	13	PBX 42-B	11	RE30-1-3	36
IE42-1 1/2	28	MB 24-DY	13	PB 42-B-3	11	RE30-1/2	36
IE42-1 1/2-3	28	MB 30-DF	13	PB 42-B-HL	11	RE30-1/2-3	36
IE42-1-3	28	MB 30-DY	13	PBX 42-D	10	RE30-1/3	36
IE42-2	28	MBM-W	13	PBX 48-B	11	RE30-1/3-3	36
IE42-2-3	28	MCD18-1	16, 17	PB 48-B-3	11	RE30-3/4	36
IE42-3-3	28	MCD18-1/3	16, 17	PB 48-B-HL	11	RE30-3/4-3	36
IE42-3/4	28	MCD18-1/4	16, 17	PB 48-D-OP	10	RE36-1	36
IE42-3/4-3	28	MCD24-1	16, 17	PBSX 30-D	10	RE36-1 1/2	36
IE48-1	28	MCD24-1 1/2	16, 17	PBSX 36-B	11	RE36-1 1/2-3	36
IE48-1 1/2	28	MCD24-1/2	16, 17	PBS 36-B-3	11	RE36-1-3	36
IE48-1 1/2-3	28	MCD24-1/3	16, 17	PBS 36-B-HL	11	RE36-1/2	36
IE48-1-3	28	MCD24-1/4	16, 17	PBSX 36-D	10	RE36-1/2-3	36
IE48-2	28	MCD24-3	16, 17	PBSX 42-B	11	RE36-1/3	36
IE48-2-3	28	MCD24-3/4	16, 17	PBS 42-B-3	11	RE36-1/3-3	36
IE48-3-3	28	MCD30-1	16, 17	PBS 42-B-HL	11	RE36-2	36
IE48-3/4	28	MCD30-1 1/2	16, 17	PBSX 42-D	10	RE36-2-3	36
IE48-3/4-3	28	MCD30-1/2	16, 17	PBSX 48-B	11	RE36-3/4	36
IE48-5-3	28	MCD30-1/3	16, 17	PBS 48-B-3	11	RE36-3/4-3	36
IE60-2	28	MCD30-2	16, 17	PBS 48-B-HL	11	RE42-1	36
IE60-2-3	28	MCD30-3	16, 17	PBS 48-D-OP	10	RE42-1 1/2	36
IE60-3-3	28	MCD30-3/4	16, 17	PCBT 36-B	13	RE42-1 1/2-3	36
IE60-5-3	28	MCD36-1	16, 17	PCBT 42-B	13	RE42-1-3	36
IED12-1/4	27	MCD36-1 1/2	16, 17	PCBT 48-B	13	RE42-1/2	36
IED12-1/4-3	27	MCD36-2	16, 17	PM-1	19	RE42-1/2-3	36
IED16-1/3	27	MCD36-3	16, 17	PM-1.5	19	RE42-2	36
IED16-1/3-3	27	MCD36-5	16, 17	PM-2	19	RE42-2-3	36
IED18-1/2	27	MCD42-2	16	PM-2.5	19	RE42-3-3	36
IED18-1/2-3	27	MCD42-5	16	PM-3	19	RE42-3/4	36
IED20-3/4	27	MCD48-10	16	QH-2	43	RE42-3/4-3	36
IED20-3/4-3	27	MCD48-5	16	RDS-18	35	RE48-1	36



MODEL	PAGE	MODEL	PAGE	MODEL	PAGE	MODEL	PAGE
RE48-1 1/2	36	SLS-54	35	TXB24-1-3	40	TXD18-1/2-3	38
RE48-1 1/2-3	36	SLS-60	35	TXB24-1/2	40	TXD18-1/3	38
RE48-1-3	36	SR-12	33	TXB24-1/2-3	40	TXD18-1/3-3	38
RE48-2	36	SR-16	33	TXB24-2	40	TXD18-1/4	38
RE48-2-3	36	SR-18	33	TXB24-2-3	40	TXD18-1/4-3	38
RE48-3-3	36	SR-20	33	TXB24-3-3	40	TXD24-1	38
RE48-3/4	36	SR-24	33	TXB24-3/4	40	TXD24-1-3	38
RE48-3/4-3	36	SW-1	16	TXB24-3/4-3	40	TXD24-1/2	38
RE48-5-3	36	SW-1 1/2	16	TXB27-1	40	TXD24-1/2-3	38
RE54-1	36	SW-1 1/2-3	16	TXB27-1 1/2	40	TXD24-1/3	38
RE54-1 1/2	36	SW-1-3	16	TXB27-1 1/2-3	40	TXD24-1/3-3	38
RE54-1 1/2-3	36	SW-1/2	16	TXB27-1-3	40	TXD24-1/4	38
RE54-1-3	36	SW-1/2-3	16	TXB27-2	40	TXD24-1/4-3	38
RE54-2	36	SW-1/4	16	TXB27-2-3	40	TXD24-2	38
RE54-2-3	36	SW-1/4-3	16	TXB27-3/4	40	TXD24-2-3	38
RE54-3-3	36	SW-2-3	16	TXB27-3/4-3	40	TXD24-3-3	38
RE54-5-3	36	SW-3-3	16	TXB30-1	40	TXD24-3/4	38
RE60-1	36	SW-5-3	16	TXB30-1 1/2	40	TXD24-3/4-3	38
RE60-1 1/2	36	SW-7 1/2-3	16	TXB30-1 1/2-3	40	TXD27-1	38
RE60-1 1/2-3	36	TL-RB-18	44	TXB30-1-3	40	TXD27-1-3	38
RE60-1-3	36	TXB12-1/2	40	TXB30-1/2	40	TXD27-1/2	38
RE60-2	36	TXB12-1/2-3	40	TXB30-1/2-3	40	TXD27-1/2-3	38
RE60-2-3	36	TXB12-1/3	40	TXB30-2	40	TXD27-2	38
RE60-3-3	36	TXB12-1/3-3	40	TXB30-2-3	40	TXD27-2-3	38
RE60-5-3	36	TXB12-1/4	40	TXB30-3-3	40	TXD30-1/2	38
RE60-7 1/2-3	36	TXB12-1/4-3	40	TXB30-5-3	40	TXD30-1/2-3	38
SBX 30-D	12	TXB12-3/4	40	TXB34-1 1/2	40	TXD30-2	38
SBX 36-B	12	TXB12-3/4-3	40	TXB34-1 1/2-3	40	TXD30-2-3	38
SB 36-B-3	12	TXB15-1/2	40	TXB34-2	40	TXD30-3-3	38
SB 36-B-HL	12	TXB15-1/2-3	40	TXB34-2-3	40	TXD30-3/4	38
SBX 36-D	12	TXB15-1/3	40	TXB34-3-3	40	TXD30-3/4-3	38
SBX 42-B	12	TXB15-1/3-3	40	TXB34-5-3	40	TXD34-1 1/2	38
SB 42-B-3	12	TXB15-1/4	40	TXB42-1 1/2	40	TXD34-1 1/2-3	38
SB 42-B-HL	12	TXB15-1/4-3	40	TXB42-1 1/2-3	40	TXD34-2	38
SBX 42-D	12	TXB15-3/4	40	TXB42-2	40	TXD34-2-3	38
SBX 48-B	12	TXB15-3/4-3	40	TXB42-2-3	40	TXD34-3-3	38
SB 48-B-3	12	TXB18-1	40	TXB42-3-3	40	TXD34-5-3	38
SB 48-B-HL	12	TXB18-1 1/2	40	TXB42-5-3	40	TXD36-2	38
SF-12	33	TXB18-1 1/2-3	40	TXB48-5-3	40	TXD36-2-3	38
SF-16	33	TXB18-1-3	40	TXB48-7 1/2-3	40	TXD36-3-3	38
SF-18	33	TXB18-1/2	40	TXD12-1/2	38	TXD42-1-3	38
SF-20	33	TXB18-1/2-3	40	TXD12-1/2-3	38	TXD42-2	38
SF-24	33	TXB18-1/3	40	TXD12-1/4	38	TXD42-2-3	38
SLS-18	35	TXB18-1/3-3	40	TXD12-1/4-3	38	TXD42-3-3	38
SLS-24	35	TXB18-1/4	40	TXD12-3/4	38	TXD42-5-3	38
SLS-30	35	TXB18-1/4-3	40	TXD12-3/4-3	38	TXD48-3-3	38
SLS-36	35	TXB24-1	40	TXD18-1	38	TXD48-5-3	38
SLS-42	35	TXB24-1 1/2	40	TXD18-1-3	38	TXG-12	38
SLS-48	35	TXB24-1 1/2-3	40	TXD18-1/2	38	TXG-15	38

# Product Index Listing

49

INDEX

MODEL	PAGE	MODEL	PAGE	MODEL	PAGE	MODEL	PAGE
TXG-18	38	UEB48-3-3	37	UED48-5-3	36		
TXG-24	38	UEB48-3/4	37	UED48-7 1/2-3	36		
TXG-27	38	UEB48-3/4-3	37	UED60-5-3	36		
TXG-30	38	UEB54-1	37	UED60-7 1/2-3	36		
TXG-34	38	UEB54-1 1/2	37	UHP 24-P	4		
TXG-36	38	UEB54-1 1/2-3	37	UHP 24-PJR	4		
TXG-42	38	UEB54-1-3	37	UHP 24-W	4		
TXG-48	38	UEB54-2	37	UHP 24-WJR	4		
U-12-TE	37	UEB54-2-3	37	UHP 30-IJR	4		
U-18-TE	19	UEB54-3-3	37	UHP 30-P	4		
U-18-TE-HD	19	UEB54-5-3	37	UHP 30-PJR	4		
U-24-TE	19	UEB60-1 1/2	37	UHP 30-W	4		
U-24-TE-HD	19	UEB60-1 1/2-3	37	UHP 30-WJR	4		
U-24-TE-HV	19	UEB60-2	37	WACM-P	6		
UEB24-1/2	37	UEB60-2-3	37	WACM-W	6		
UEB24-1/2-3	37	UEB60-3-3	37	WH-12	34		
UEB24-1/3	37	UEB60-5-3	37	WH-16	34		
UEB24-1/3-3	37	UED18-1	36	WH-18	34		
UEB24-3/4	37	UED18-1-3	36	WH-20	34		
UEB24-3/4-3	37	UED18-1/2	36	WH-24	34		
UEB30-1	37	UED18-1/2-3	36	WH-30	34		
UEB30-1-3	37	UED18-1/3	36	WH-36	34		
UEB30-1/2	37	UED18-1/3-3	36	WH-42	34		
UEB30-1/2-3	37	UED18-1/4	36	WH-48	34		
UEB30-3/4	37	UED18-1/4-3	36	WH-60	34		
UEB30-3/4-3	37	UED24-1	36				
UEB36-1	37	UED24-1-3	36				
UEB36-1 1/2	37	UED24-1/4	36				
UEB36-1 1/2-3	37	UED24-1/4-3	36				
UEB36-1-3	37	UED24-3-3	36				
UEB36-1/2	37	UED24-3/4	36				
UEB36-1/2-3	37	UED24-3/4-3	36				
UEB36-3/4	37	UED30-1 1/2	36				
UEB36-3/4-3	37	UED30-1 1/2-3	36				
UEB42-1	37	UED30-1-3	36				
UEB42-1 1/2	37	UED30-2	36				
UEB42-1 1/2-3	37	UED30-2-3	36				
UEB42-1-3	37	UED30-3-3	36				
UEB42-2	37	UED30-3/4	36				
UEB42-2-3	37	UED30-3/4-3	36				
UEB42-3-3	37	UED36-2	36				
UEB42-3/4	37	UED36-2-3	36				
UEB42-3/4-3	37	UED36-3-3	36				
UEB48-1	37	UED36-5-3	36				
UEB48-1 1/2	37	UED42-2	36				
UEB48-1 1/2-3	37	UED42-2-3	36				
UEB48-1-3	37	UED42-5-3	36				
UEB48-2	37	UED48-10-3	36				
UEB48-2-3	37	UED48-3-3	36				