

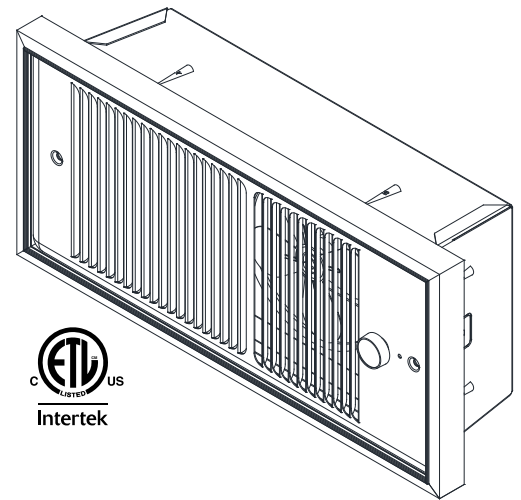

- Powder coated 20 gauge steel with extruded aluminum frame
- Manual reset thermal limit
- Finned tubular steel element
- Propellar style fan blade produces 70 CFM
- In-Built tamper proof thermostat
- Left, right, or top discharge
- Dual wattage and voltage units available for 208/240 volts
- Surface Mounting Frames available for non-recessed and semi-recessed applications



### Standard Models

MFG CATALOG NUMBER	MFG MODEL NUMBER	VOLTS	WATTS	MAX BTUs	AMPS
<b>DOUBLE POLE IN-BUILT THERMOSTAT (RANGE 0° - 110° F)</b>					
03283202	F4420T2RP	208	2000	6826	9.6
03283302	HF4475T2RP	240/208	750 / 562	2560 / 1920	3.1 / 2.7
03283402	HF4410T2RP		1000 / 750	3413 / 2560	4.2 / 3.6
03283502	HF4415T2RP		1500 / 1125	5120 / 3840	6.3 / 5.4
03283602	HF4420T2RP		2000 / 1500	6826 / 5120	8.3 / 7.2
<b>SINGLE POLE IN-BUILT THERMOSTAT (RANGE 0° - 110° F)</b>					
03283702	E4475TRP	120	750	2560	6.25
03283802	E4410TRP		1000	3413	8.33
03283902	E4415TRP		1500	5120	12.5
03284002	F4420TRP	208	2000	6826	9.6

### Accessories

MFG CATALOG NUMBER	MFG MODEL NUMBER	DESCRIPTION	WT. (LBS)
03299102	4400EX8	1" SEMI RECESSING EXTENDER	2
03299002	4400EX16	2" SEMI RECESSING EXTENDER	3
03298902	4400EX32	4" SURFACE MOUNTING FRAME	4
03284402	4300PB	WALL PLATE ADAPTOR (OD 21.5"x12.25")	1