

FOSTORIA INDUSTRIES®

114 Roscoe Fitz Road

Gray, TN 37615

Phone: 800-495-4525

Fax: 419-435-0842

www.fostoriaindustries.com

Division of TPI Corporation



Quality Since 1917

SUN-MITE®

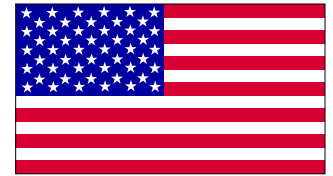

FES - Series
Portable Electric Heaters

YES - Series
Suspended Electric Heaters



	 WARNING
	 AVERTISSEMENT
	<p style="text-align: center; color: red; margin: 0;">IMPORTANT SAFETY INFORMATION INSIDE CONSIGNES DE SÉCURITÉ IMPORTANTES À L'INTÉRIEUR</p> <ul style="list-style-type: none"> • Serious injury or death possible. des blessures graves ou la mort possible. • Read, understand, and follow all safety information and instructions in this manual before using or servicing this product. Lire, comprendre et suivre toutes les consignes de sécurité et instructions de ce manuel avant d'utiliser ou de réparer ce produit. • Retain these instructions for future reference. Conserver ces instructions pour référence ultérieure.

CONTENTS

Specifications	Page 3,4
YES Installation	Page 5
FES Assembly	Page 6
Wiring	Page 7, 8, 9,10
Operating	Page 11
Replacement Parts	Page 12, 13, 14
Maintenance	Page 15

IMPORTANT INSTRUCTIONS

When using electrical appliances, basic precautions should always be followed to reduce the risk of fire, electrical shock, and injury to persons, including the following:

1. Read all instructions before using this heater.
2. **CAUTION:** High temperatures. Keep cords and all other combustible material, such as furniture, papers, clothes and curtains away from the heater. For safe and efficient operation, keep an open space around heater of 3 feet in front and 12 inches at ends and rear.

ATTENTION: Les températures élevées. Gardez les cordons et tout autre matériau combustible, tels que les meubles, papiers, vêtements et rideaux à l'extérieur de l'appareil de chauffage. Pour un fonctionnement sûr et efficace, garder un espace ouvert autour de chauffage de trois pieds à l'avant et 12 pouces aux extrémités et à l'arrière.

3. Extreme caution is necessary when any heater is used by or near children or invalids and whenever the heater is left operating and unattended.
4. Do not operate any heater after it malfunctions, has been dropped or damaged in any manner. Return heater to authorized service facility for examination, electrical or mechanical adjustment, or repair.
5. Do not use outdoors.
6. To disconnect heater, turn controls to off, and turn off power to heater circuit at main disconnect panel (or operate internal disconnect switch if provided).
7. Do not insert or allow foreign objects to enter any ventilation or exhaust opening as this may cause an electric shock or fire, or damage the heater.
8. To prevent a possible fire, do not block air intakes or exhaust in any manner.
9. A heater has hot and arcing or sparking parts inside. **WARNING:** Do not use it in area where gasoline, paint, or flammable liquids are used or stored.
10. Use this heater only as described in this manual. Any other use not recommended by the manufacturer may cause fire, electric shock, or injury to persons.
11. This heater may include an audible or visual alarm to warn that parts of the heater are getting excessively hot. If the alarm sounds (or illuminates), immediately turn the heater off and inspect for any objects on or adjacent to the heater that may have blocked the airflow or otherwise caused high temperatures to have occurred.
DO NOT OPERATE THE HEATER WITH THE ALARM SOUNDING (OR ILLUMINATING)

12. SAVE THESE INSTRUCTIONS

SPECIFICATIONS

Portable Electric Heaters

MODEL	PART NUMBER	kW	Volts	PH	AMPS	FAN OUTPUT	HEAT OUTPUT	DIM. A
FES-0924-1C	08743302	9	240	1	38	800 CFM	30717 BTUH	21"
FES-1024-1CA	08860010	10	240	1	42	800 CFM	34130 BTUH	21"
FES-1520-3A	08860110	15	208	3	42	800 CFM	51195 BTUH	21"
FES-1524-1A	08860710	15	240	1	63	800 CFM	51195 BTUH	21"
FES-1524-3E	08860210	15	240	3	36	800 CFM	51195 BTUH	21"
FES-1548-3E	08860310	15	480	3	18	800 CFM	51195 BTUH	21"
FES-1560-3A	08860410	15	600	3	15	800 CFM	51195 BTUH	21"
FES-3048-3A	08860510	30	480	3	36	1100 CFM	102390 BTUH	23"
FES-3060-3A	08860610	30	600	3	29	1100 CFM	102390 BTUH	23"

Suspended Electric Heaters

MODEL	PART NUMBER	kW	Volts	PH	AMPS	FAN OUTPUT	HEAT OUTPUT	DIM. B
YES-1024-1CA	08861510	10	240	1	42	800 CFM	34130 BTUH	36"
YES-1520-3A	08860810	15	208	3	42	800 CFM	51195 BTUH	36"
YES-1524-1A	08861810	15	240	1	63	800 CFM	51195 BTUH	36"
YES-1524-3E	08860910	15	240	3	36	800 CFM	51195 BTUH	36"
YES-1548-3E	08861010	15	480	3	18	800 CFM	51195 BTUH	36"
YES-1560-3A	08861110	15	600	3	15	800 CFM	51195 BTUH	36"
YES-3048-3A	08861210	30	480	3	36	1100 CFM	102390 BTUH	38"
YES-3060-3A	08861310	30	600	3	29	1100 CFM	102390 BTUH	38"

Description – Fostoria portable and suspended electric heaters provide clean, quiet, odor-free, fan-forced heat. They are designed to circulate room air continuously; gradually heating a confined space. The best results will be obtained when using these heaters in smaller, insulated spaces. Features include a safety-yellow enclosure with front and rear safety screens; reliable stainless steel finned heating elements; a high-limit temperature switch with automatic reset; an automatic thermostat control with fan-only option; and a long-life motor and fan assembly with sealed bearings. The portable (FES) models come mounted on a two-wheeled cart with wheels designed to be easily pushed or pulled over uneven surfaces.

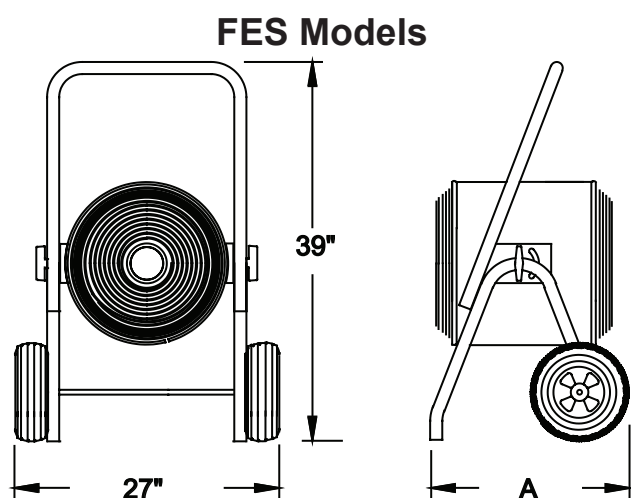

All Fostoria FES models come fully-assembled except the handle is attached in a lowered shipping position when shipped from the factory. Dimensions above are for handle in operating position. See page 5 for final assembly of handle.

YES Models

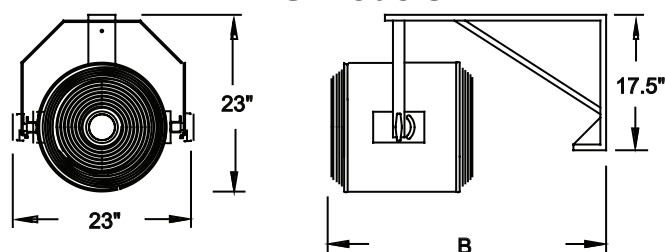

YES models are shipped with the following items. Check to make certain all parts are at hand prior to beginning the installation.

QTY	DESCRIPTION	QTY	DESCRIPTION
1	Bracket wall /ceiling	1	Rotating stop - Top
1	Hanger	1	Nut stop 1/2-13
4	Washer Steel	1	Bolt 1/2-13 x 1-1/2
2	Knob	1	Nylon washer
2	Washer rubber	2	Rotating stop - side

SPECIFICATIONS PORTABLE FES BUNDLED MODELS

MODEL	PART NUMBER	kW	Volts	PH	AMPS	FAN OUTPUT	HEAT OUTPUT	DIM. A
F15-FES-3A	07396702	15	208	3	42	800 CFM	51195 BTUH	21"
H15-FES-1A	07396802	15	240	1	63	800 CFM	51195 BTUH	21"
H15-FES-3E	07396902	15	240	3	36	800 CFM	51195 BTUH	21"
P15-FES-3E	07397002	15	480	3	18	800 CFM	51195 BTUH	21"
U15-FES-3A	07402902	15	600	3	15	800 CFM	51195 BTUH	21"
P30-FES-3A	07397102	30	480	3	36	1100 CFM	102390 BTUH	23"
U30-FES-3A	07403002	30	600	3	29	1100 CFM	102390 BTUH	23"

The FES bundled models are provided from the factory with fifteen feet of SO cable. Additional cable lengths may be used. The following charts give the maximum cable lengths and sizes for these units. For wiring refer to pages 8 thru 10.

Model Table 1	Unit Rating	Cable Size - Under 50ft. long	Cable Kit Number
F15-FES-3A	15kW, 208 Volt, 3-Ph	6/4	03164001
H15-FES-1A	15kW, 240 Volt, 1-Ph	4/3	08805300
H15-FES-3E	15kW, 240 Volt, 3-Ph	6/4	03164001
P15-FES-3E	15kW, 480 Volt, 3-Ph	12/4	03164201
U15-FES-3A	15kW, 600 Volt, 3-Ph	12/4	03164201
P30-FES-3A	30kW, 480 Volt, 3-Ph	6/4	03164001
U30-FES-3A	30kW, 600 Volt, 3-Ph	6/4	03164001

A 25ft. cable kit can be purchased from the factory. Refer to the kit part numbers in table above.

CABLE KITS INCLUDE:

- 25 feet of Type SO cable, with either 3-conductors or 4-conductors, depending on the heater requirements.

To order cable kits
Phone: 1-800-495-4525

Model Table 2	Unit Rating	Cable Size - Over 50ft. long	Max. Cable Length (ft)
F15-FES-3A	15kW, 208 Volt, 3-Ph	4/4	120
H15-FES-1A	15kW, 240 Volt, 1-Ph	2/3	215
H15-FES-3E	15kW, 240 Volt, 3-Ph	6/4	150
P15-FES-3E	15kW, 480 Volt, 3-Ph	12/4	140
U15-FES-3A	15kW, 600 Volt, 3-Ph	12/4	190
P30-FES-3A	30kW, 480 Volt, 3-Ph	6/4	300
U30-FES-3A	30kW, 600 Volt, 3-Ph	6/4	350

YES - SERIES INSTALLATION

ALL Fostoria YES models require some assembly. Four steps are required to complete the assembly and installation.

Tools required: (2) 3/4" socket or box wrenches.

Parts required: the two screws required to secure wall/ceiling bracket to a suitable surface are not supplied with heater. You must use 5/16" bolts and flat washers to mount this bracket.

Step 1: Install (1) side rotating stop over bolt and into curved slot (as shown at right) on each side of heater.

Step 2: Assemble hanger to heater per hanger assembly detail. No tools are required.

Step 3: Secure wall/ceiling mounting bracket to appropriate surface that will support a min. weight of 100 lbs continuously. **NOTE:** all mounting hardware to mount hanger to wall/ceiling bracket is supplied with heater.

Step 4: Assemble unit to mounting bracket following instructions of chosen mounting option below.

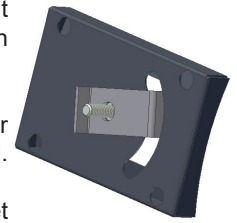

Hanger Assembly Detail

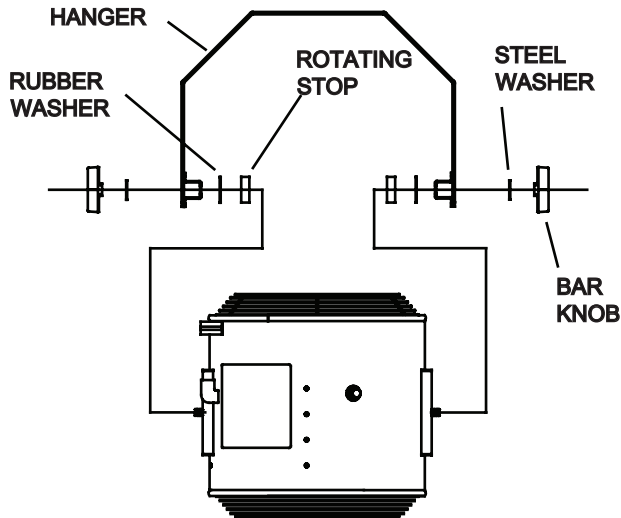

Ceiling Mount Option

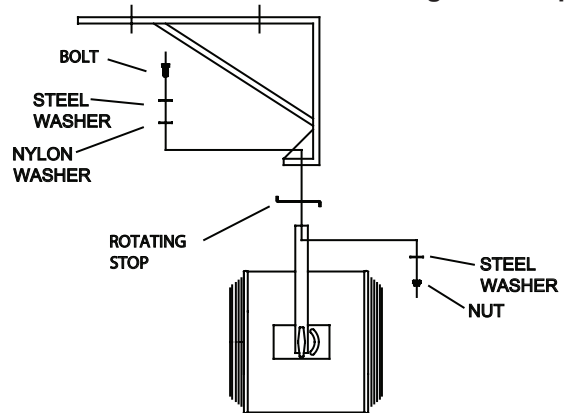

Wall Mount Option #1

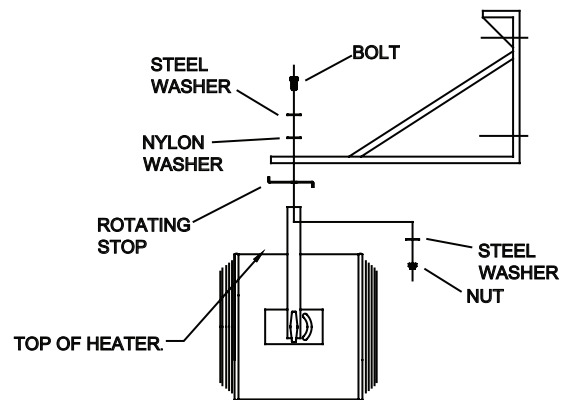

Wall Mount Option #2

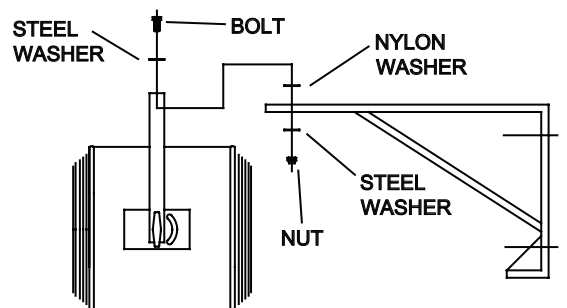

  	<h3 style="margin: 0;">⚠ WARNING</h3> <h3 style="margin: 0;">⚠ AVERTISSEMENT</h3>
	<p>FALLING OBJECTS HAZARD FIRE HAZARD CHUTES D'OBJETS LES RISQUES RISQUE D'INCENDIE</p>
	<ul style="list-style-type: none"> Serious injury or death may occur. Blessures graves ou la mort peuvent survenir. Read and follow all safety information and instructions in box below. Lire et suivre toutes les consignes de sécurité et les instructions dans la boîte ci-dessous.
<ul style="list-style-type: none"> Mounting bracket supplied with YES models <u>MUST</u> be used to support heater. Installer <u>MUST</u> be certain surface that bracket is mounted to will support 100 lbs of weight continuously. Rotating stops <u>MUST</u> be installed as shown above. Do not mount heater upside down (See nameplate label for "TOP" of heater.) The bottom of these units must be mounted at least 6 ft. off the floor and the top 2 ft. from the ceiling. Do not suspend <u>ANY</u> other equipment from this bracket. One heater per bracket 	

FES – SERIES ASSEMBLY

Tools Required: (2) 7/16" socket or box wrenches.

To position the handle at operating height:

Step 1: Remove and keep the hardware securing the handle to the legs.

Step 2: Raise handle until holes align with the upper holes in the legs.

Step 3: Re-insert hardware as shown, and fasten securely.

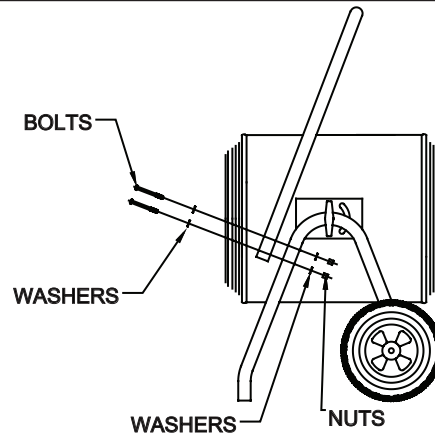

WIRING

THE PROPER SIZE SO- type feeder cable MUST BE USED for the electrical hook-up of this heater. The proper cable size is shown in the tables below (A.W.G./ # of conductors.) Table 1 is for cable 50ft. in length or less. Table 2 is for cable longer than 50ft.

A 25ft. cable kit can be purchased from the factory. Refer to the kit part numbers in table at right.

CABLE KITS INCLUDE:

- 25 feet of Type SO cable, with either 3-conductors or 4-conductors, depending on the heater requirements.

To order cable kits
Phone: 1-800-495-4525

Model Table 1	Unit Rating	Cable Size - Under 50ft. long	Cable Kit Number
FES1520-3A	15kW, 208 Volt, 3-Ph	6/4	03164001
FES1524-1A	15kW, 240 Volt, 1-Ph	4/3	08805300
FES1524-3E	15kW, 240 Volt, 3-Ph	6/4	03164001
FES1548-3E	15kW, 480 Volt, 3-Ph	12/4	03164201
FES1560-3A	15kW, 600 Volt, 3-Ph	12/4	03164201
FES3048-3A	30kW, 480 Volt, 3-Ph	6/4	03164001
FES3060-3A	30kW, 600 Volt, 3-Ph	6/4	03164001

Model Table 2	Unit Rating	Cable Size - Over 50ft. long	Max. Cable Length (ft)
FES1520-3A	15kW, 208 Volt, 3-Ph	4/4	120
FES1524-1A	15kW, 240 Volt, 1-Ph	2/3	215
FES1524-3E	15kW, 240 Volt, 3-Ph	6/4	150
FES1548-3E	15kW, 480 Volt, 3-Ph	12/4	140
FES1560-3A	15kW, 600 Volt, 3-Ph	12/4	190
FES3048-3A	30kW, 480 Volt, 3-Ph	6/4	300
FES3060-3A	30kW, 600 Volt, 3-Ph	6/4	350

- Feeder cable or cable kit assembly **MUST BE** made by licensed electricians ONLY.
- Service panel or receptacle used to supply power to these heaters **MUST** have a ground bus or ground pole that is securely bonded to earth ground.
- Connect green ground conductor on feeder cable or cable kit to grounding lug on heaters.
- Comply with ALL local electrical codes and the National Electric Code (NFPA70) when providing electrical power to these heaters.



⚠ WARNING

⚠ ADVERTENCIA

**ELECTRICAL SHOCK HAZARD
FIRE HAZARD**

RISQUE DE CHOC ÉLECTRIQUE
RISQUE D'INCENDIE

- **Serious injury or death may occur**
Blessures graves ou la mort peuvent survenir.
- **Disconnect from electrical supply before installing feeder cable to these heaters.**
- Couper l'alimentation électrique avant d'installer un câble d'alimentation de ces appareils de chauffage.
- **Read and follow all safety information in box to the left.**
Lire et suivre toutes les consignes de sécurité dans la boîte vers la gauche.

WIRING (continued)

FES-1024-1CA, FES-0924-1C

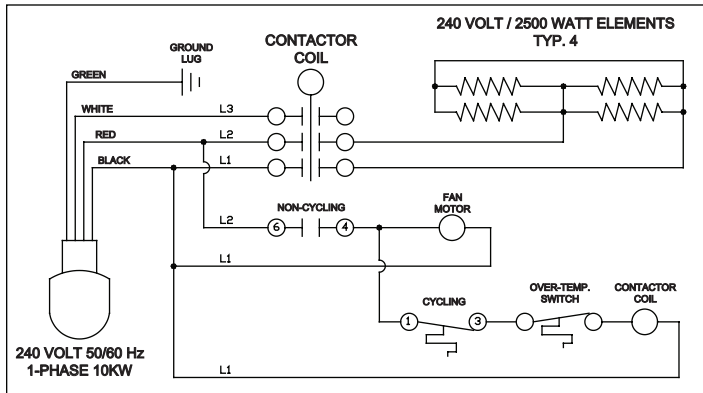

Models FES-1024-1CA and FES-0924-1C are shipped with a cordset factory-installed. This cordset contains a plug for use with a 50A household range receptacle. The blade configuration on the plug included on these heaters is represented in fig. 1 below (4-wire circuit).

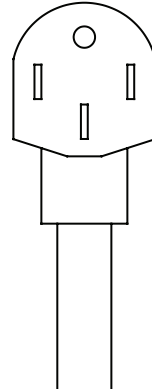

fig. 1

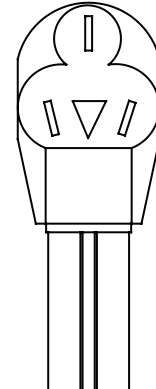

fig. 2

The range receptacle you choose to use may have a blade configuration compatible with the plug shown in fig. 2 (3-wire circuit). This is an older branch circuit design that does not include a separate equipment grounding conductor (green wire). The configuration in fig. 1 has been implemented on newer branch circuit installations for increased safety, and is now the required circuit configuration by the National Electric Code. Changing a 3-wire branch circuit and receptacle to 4-wire design may involve changes to your range and must only be done by a licensed electrician.

⚠ WARNING

⚠ AVERTISSEMENT

ELECTRICAL SHOCK HAZARD
RISQUE DE CHOC ÉLECTRIQUE



- **Serious injury or death may occur.**
Blessures graves ou la mort peuvent survenir.
- **Plug heater into a 4-wire receptacle rated 50A.**
Chauffage Branchez un circuit à 4 fils prise nominale 50A.
- **Any and all changes to branch circuits and receptacles MUST be done by a licensed electrician ONLY.**
Toutes les modifications et tous les circuits de dérivation et de récipients doivent être effectués par un électricien agréé SEULEMENT.

WIRING (continued)

YES-1524-1A

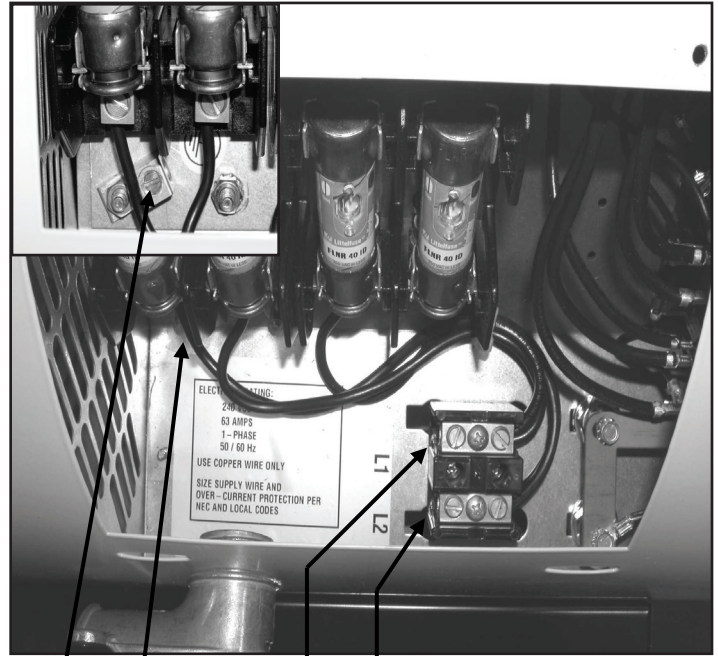
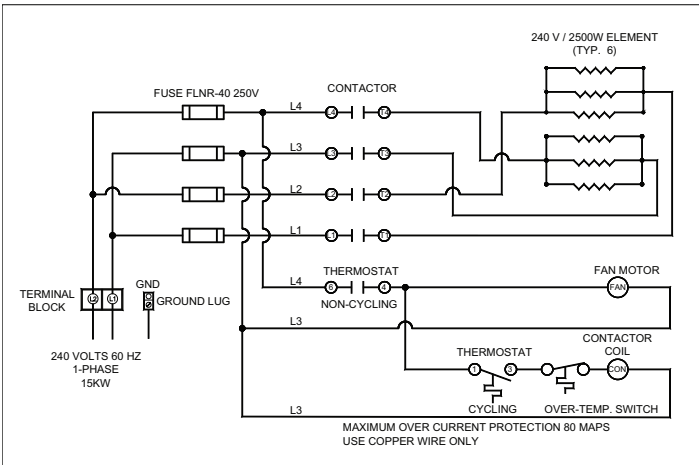

Attach feeder cable or cable kit to heater as shown in photograph at right for the single-phase models indicated.

Ground lug is located directly below fuse as shown in upper left corner. Securely attach green wire to this lug.

Attach circuit conductors at these lugs. Refer to label shown for phase identification

3-Phase Models

Attach feeder cable or cable kit to heater as shown in the photograph at left for the following 3-phase models.

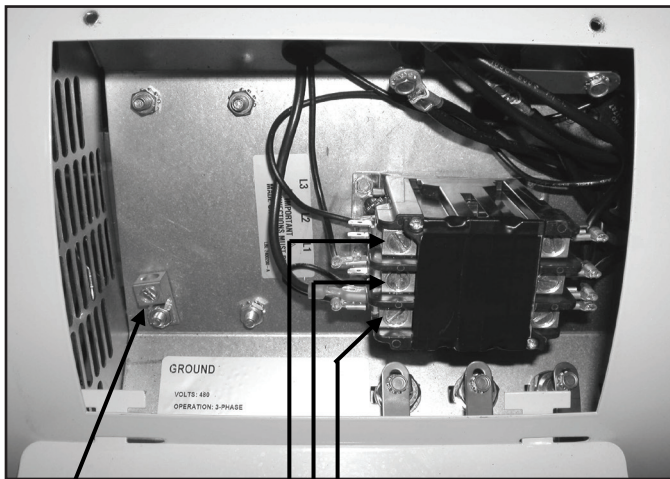

FES-1520-3A	F15-FES-3A	YES-1520-3A
FES-1524-3E	H15-FES-3E	YES-1524-3E
FES-1548-3E	P15-FES-3E	YES-1548-3E
FES-1560-3A	U15-FES-3A	YES-1560-3A
FES-3048-3A	P30-FES-3A	YES-3048-3A
FES-3060-3A	U30-FES-3A	YES-3060-3A

Ground Lug
Securely attach
green wire to this lug.

Attach circuit conductors to
the lugs on the contactor.
Refer to label shown for phase
identification.

WIRING (continued)

FES-1524-3E, H15-FES-3E & YES-1524-3E

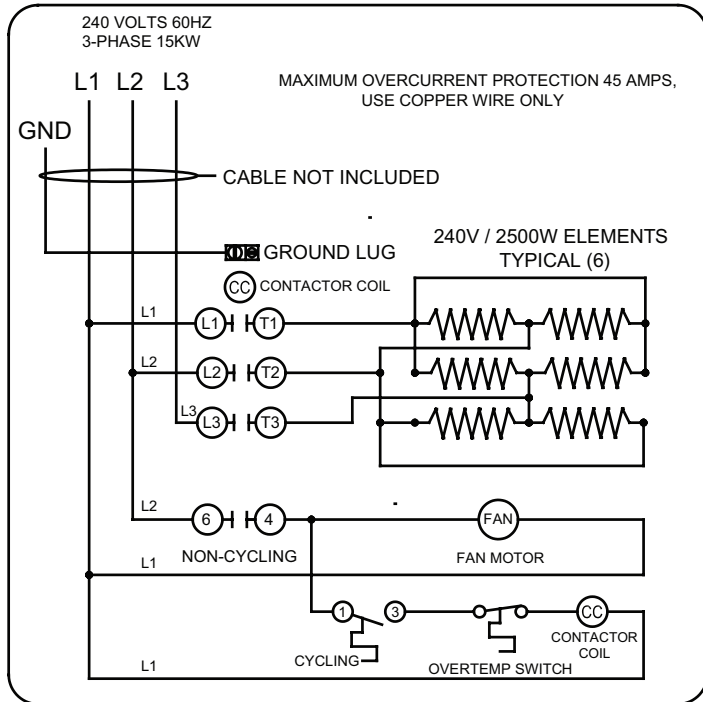

FES-1520-3A, F15-FES-3A & YES-1520-3A

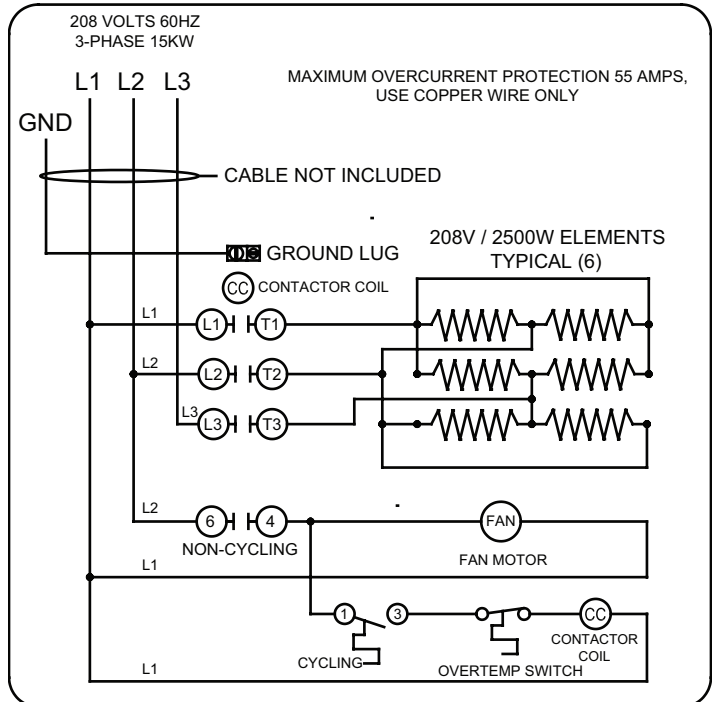

FES-1548-3E, P15-FES-3E & YES-1548-3E

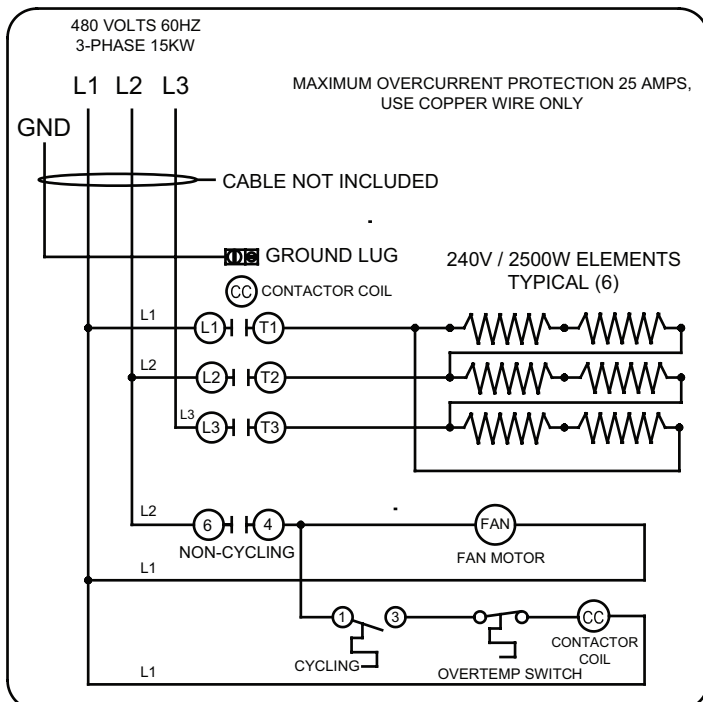

FES-1560-3A, U15-FES-3A & YES-1560-3A

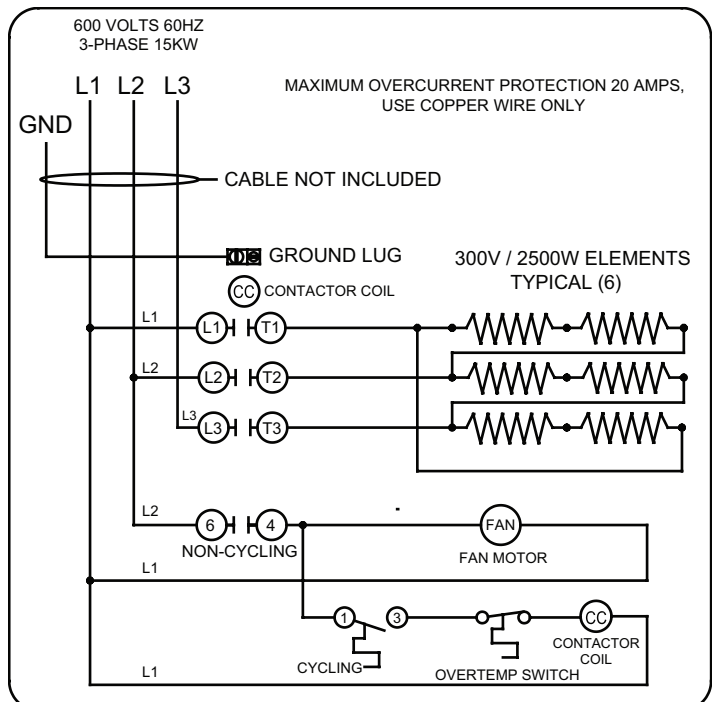

WIRING (continued)

FES-3048-3A, P30-FES-3A & YES-3048-3A

FES-3060-3A, U30-FES-3A & YES-3060-3A

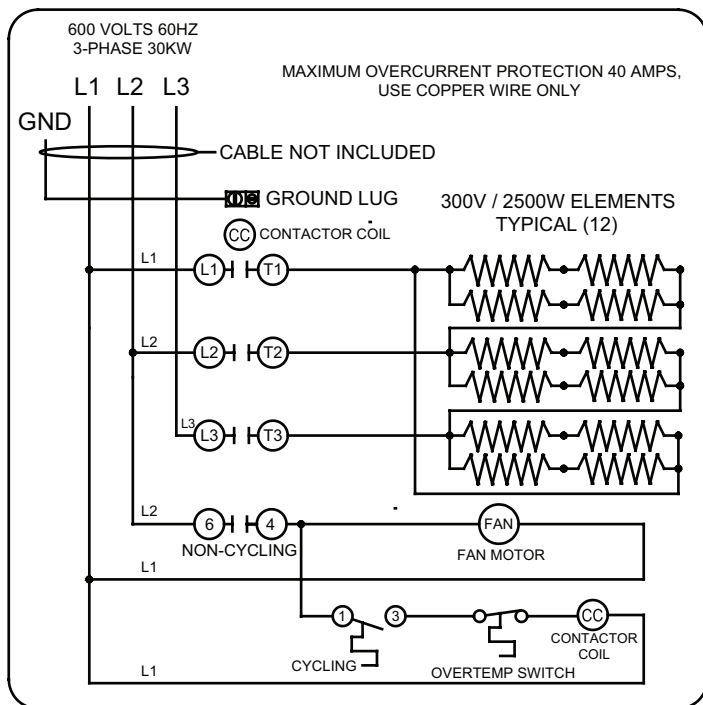
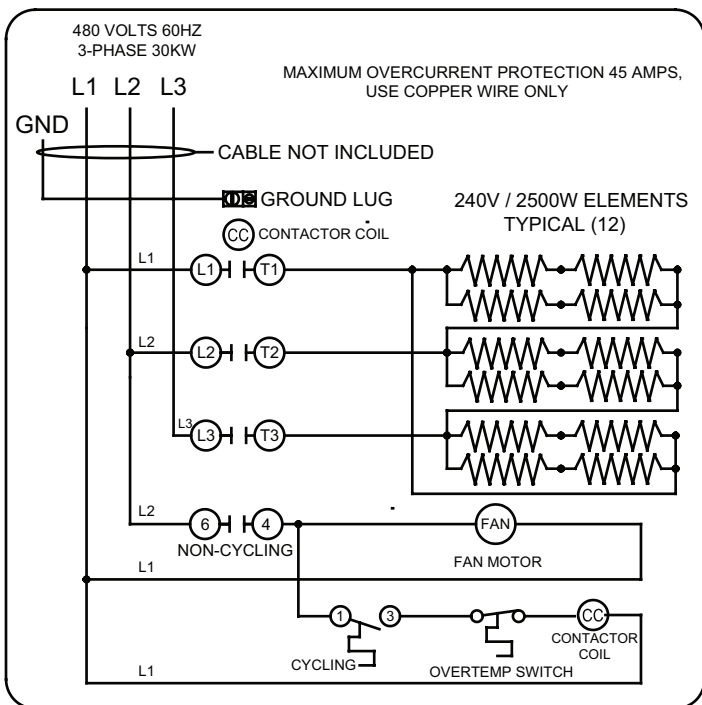

FES-1524-1A, H15-FES-1A & YES-1524-1A

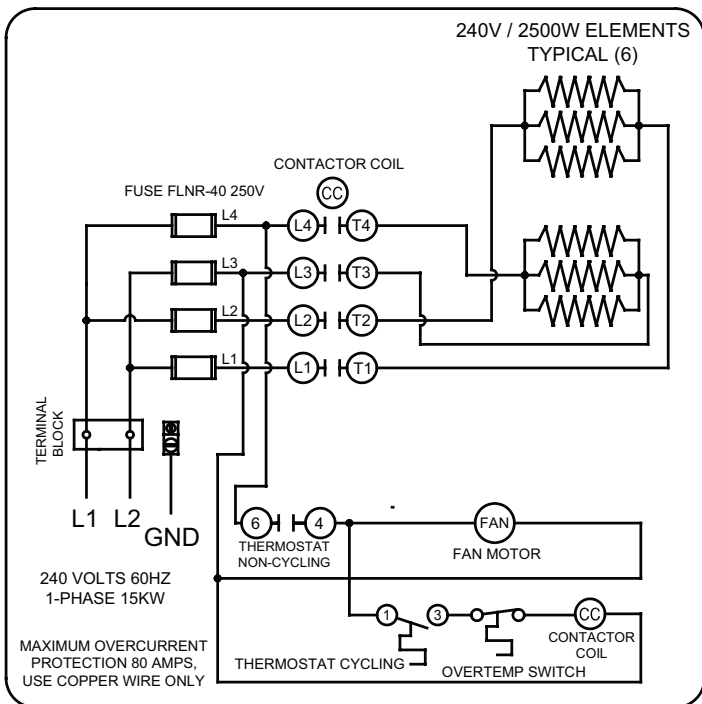

OPERATING INSTRUCTIONS

Fostoria FES and YES series heaters are designed to circulate room air across its heating elements to gradually increase room temperature. The best performance results will be obtained when using these heaters in smaller, confined spaces with low ceilings.

Operation of these heaters is accomplished via the use of a multi-function thermostat (refer to diagram below).

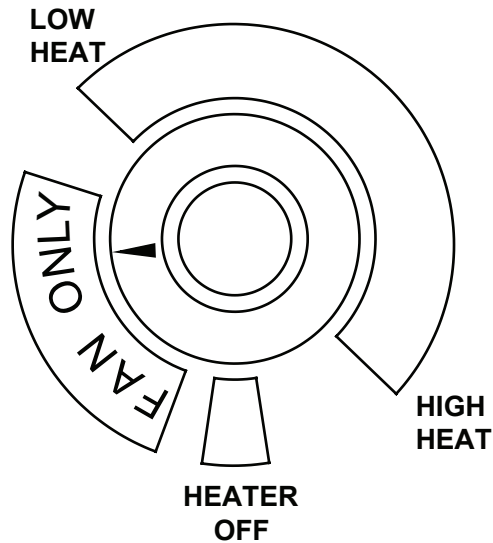

You have the option to use the fan only*, or the fan and heating elements together. Position the knob pointer in the “fan-only” area to circulate room air with no heating. Move the pointer into the “heat” area to energize the heating elements and set the thermostat. Maximum heating is obtained with knob turned fully clockwise**. Both fan and elements are off when the knob is turned fully counterclockwise.

Allow the fan to operate for a minimum of 3 minutes when you are done using the heater to purge heat from unit.

***The thermostat has a preset range of 40°F to 100°F. If the ambient room temperature is below 40°F, there will be no “fan only” function as the thermostat is always calling for heat.**

****Setting the thermostat to high heat versus low heat does not make the unit operate at a higher temperature. It simply raises the temperature necessary to satisfy the thermostat. The unit will run longer to try to satisfy a higher thermostat setting.**

Note: ALL FES/YES models are equipped with an internal over temperature limit designed to protect your heater if a restricted airflow condition occurs. This limit device will completely shut down the heating elements if the temperature limit is reached. The limit will automatically reset when the unit cools.

⚠ WARNING	
⚠ AVERTISSEMENT	
	FIRE HAZARD, BURN HAZARD, EXPLOSION HAZARD RISQUE D'INCENDIE, RISQUE DE BURN, RISQUE D'EXPLOSION
	
	
<ul style="list-style-type: none">• Serious injury or death may occur. Blessures graves ou la mort peuvent survenir.• Read and follow all safety information in box below. Lire et suivre toutes les consignes de sécurité ci-dessous.	

- Do not use outdoors or where flammable gases or liquids are stored.
- Do not use as a residential comfort heater.
- Keep portable heater 3ft. minimum from all combustible materials at all times.
- Do not modify heater in any way.
- Do not provide power to heater when unit is near standing water.
- Only use handle to move heater.
- Do not touch heater housing while in use.
- Do not allow feeder cable to contact combustible materials.
- Always purge heat from unit after use. Operate at “fan only” setting for 3 minutes.
- Extreme caution is necessary when any heater is used or near children or invalids and whenever the heater is left operating and unattended.
- Do not insert or allow foreign objects to enter any ventilation or exhaust opening as this may cause an electric shock or fire, or damage the heater.

FES REPLACEMENT PARTS LIST & EXPLODED VIEWS

Ref No.	Description	1024-1CA 0924-1C	1520-3A, F15-FES-3A	1524-3E, H15-FES-3E	1548-3E, P15-FES-3E	1560-3A, U15-FES-3A	3048-3A, P30-FES-3A	3060-3A, U30-FES-3A
1	Motor	08482001 (1)	08482001 (1)	08482001 (1)	08482002 (1)	08482003 (1)	08482004 (1)	08482005 (1)
2	Bolt carriage ½-13 x 2-3/4	32137-001 (2)	32137-001 (2)	32137-001 (2)	32137-001 (2)	32137-001 (2)	32137-001 (2)	32137-001 (2)
3	Rotating stop	32127-001 (2)	32127-001 (2)	32127-001 (2)	32127-001 (2)	32127-001 (2)	32127-001 (2)	32127-001 (2)
4	Thermostat	02470300 (1)	02470300 (1)	02470300 (1)	02470300 (1)	02470300 (1)	02470300 (1)	02470300 (1)
5	Washer Reducing (not shown)	N/A	N/A	N/A	5256 (2)	5256 (2)	N/A	N/A
6	Knob thermostat	02470500 (1)	02470500 (1)	02470500 (1)	02470500 (1)	02470500 (1)	02470500 (1)	02470500 (1)
7	Strap	32103-001 (1)	32103-001 (1)	32103-001 (1)	32103-001 (1)	32103-001 (1)	32103-001 (1)	32103-001 (1)
8	Shroud	32136-101 (1)	32103-001 (1)	32103-001 (1)	32103-001 (1)	32103-001 (1)	32103-001 (1)	32103-001 (1)
9	Motor mount bracket	32122-002 (1)	32122-002 (1)	32122-002 (1)	32122-002 (1)	32122-002 (1)	32122-001 (1)	32122-001 (1)
10	Screw 10-32x 5/16 SEMS	32110-001 (8)	32110-001(12)	32110-001(12)	32110-001(12)	32110-001(12)	32110-001(24)	32110-001(24)
11	Mount motor end	32121-001 (2)	32121-001 (2)	32121-001 (2)	32121-001 (2)	32121-001 (2)	32121-001 (2)	32121-001 (2)
12	Washer 9/16	42469-001 (8)	42469-001 (12)	42469-001 (12)	42469-001 (12)	42469-001 (12)	42469-001 (24)	42469-001 (24)
13	Nut hex ¼-20	1042 (4)	1042 (4)	1042 (4)	1042 (4)	1042 (4)	1042 (4)	1042 (4)
14	Washer ¼	1036 (8)	1036 (8)	1036 (8)	1036 (8)	1036 (8)	1036 (8)	1036 (8)
15	Grill	08480621 (2)	08480621 (2)	08480621 (2)	08480621 (2)	08480621 (2)	08480621 (2)	08480621 (2)
16	Washer	43625-004 (4)	43625-004 (4)	43625-004 (4)	43625-004 (4)	43625-004 (4)	43625-004 (4)	43625-004 (4)
17	Screw 8-18 x ½	5081	5081	5081	5081	5081	5081	5081
18	Contactora	58027-038 (1)	58027-038 (1)	58027-038 (1)	58027-035 (1)	08480403 (1)	58027-035 (1)	08480403 (1)
19	Cordset – not shown	32147-001 (1)	-----	-----	-----	-----	-----	-----
20	Nut ½-13	28952-001 (2)	28956-001 (2)	28956-001 (2)	28956-001 (2)	28956-001 (2)	28956-001 (2)	28956-001 (2)
21	Screw ¼-20 x ¾	3494156 (4)	43893-009 (4)	43893-009 (4)	43893-009 (4)	43893-009 (4)	43893-009 (4)	43893-009 (4)
22	Over temperature switch	03183900 (1)	03183900 (1)	03183900 (1)	03183900 (1)	03183900 (1)	41041-001 (1)	41041-001 (1)
23	Ground Lug	41254-001 (1)	41254-001 (1)	41254-001 (1)	41254-001 (1)	41254-001 (1)	41254-001 (1)	41254-001 (1)
24	Connector	32108-002 (1)	32108-002 (1)	32108-002 (1)	32108-001 (1)	32108-001 (1)	32108-002 (1)	32108-002 (1)
25	Baffle – not shown	32130-001 (1)	32130-001 (1)	32130-001 (1)	32130-001 (1)	32130-001 (1)	32130-001 (1)	32130-001 (1)
26	Bussbar – not shown	32115-001 (4)	32115-001 (8)	32115-001 (8)	32115-001 (5)	32115-001 (5)	32115-001 (10)	32115-001 (10)
27	Element inner 1024-C1A	08481401 (2)	08481403 (3)	08481401 (3)	08481401 (3)	08481405 (3)	08481401 (6)	08481405 (6)
	0924-C1	91005-021 (2)						
28	Element outer 1024-C1A	08481402 (2)	08481404 (3)	08481402 (3)	08481402 (3)	08481406 (3)	08481402 (6)	08481406 (6)
	0924-C1	91005-022 (2)						
29	Blade fan – not shown	08422300 (1)	08422300 (1)	08422300 (1)	08422300 (1)	08422300 (1)	08422300 (1)	08422300 (1)
30	Cover	32125-101 (1)	32125-101 (1)	32125-101 (1)	32125-101 (1)	32125-101 (1)	32125-101 (1)	32125-101 (1)
35	Flanged Inlet Cover	N/A	58769-102 (1)	58769-102 (1)	58769-102 (1)	58769-102 (1)	58769-102 (1)	58769-102 (1)
36	Flanged Inlet Recept.	N/A	58758-003 (1)	58758-003 (1)	58758-001 (1)	58758-002 (1)	58758-004 (1)	58758-002 (1)
37	Locking Connector	N/A	58759-003 (1)	58759-003 (1)	58759-001 (1)	58759-002 (1)	58759-004 (1)	58759-002 (1)

FES REPLACEMENT PARTS LIST & EXPLODED VIEWS

Ref No.	Description	1524-1A, H15-FES-1A
1	Motor	08482001 (1)
2	Bolt carriage 1/2-13 x 2-3/4	32137-001 (2)
3	Rotating stop	32127-001 (2)
4	Thermostat	02470300 (1)
5	Washer Reducing (not shown)	N/A
6	Knob thermostat	02470500 (1)
7	Strap	32103-001 (1)
8	Shroud	32136-101 (1)
9	Motor mount bracket	32122-001 (1)
10	Screw 10-32x 5/16 SEMS	32110-001 (12)
11	Mount motor end	32121-001 (2)
12	Washer 9/16	42469-001 (12)
13	Nut hex 1/4-20	1042 (4)
14	Washer 1/4	1036 (10)
15	Grill	08480621 (2)
16	Washer	43625-004 (4)
17	Screw 8-18 x 1/2	5081
18	Contactors	58027-053 (1)
19		
20	Nut 1/2-13	28956-001 (2)
21	Screw 1/4-20 x 3/4	43893-009 (4)
22	Over temperature switch	03183900 (1)
23	Ground Lug	41254-001 (1)
24	Connector	32108-002 (1)
25	Baffle - not shown	32130-001 (1)
26	Bussbar - not shown	32115-001 (8)
27	Element inner 1024-C1A	08481401 (3)
28	Element outer 1024-C1A	08481402 (2)
29	Blade fan - not shown	08422300 (1)
30	Cover	32125-101 (1)
31	Bracket fuse block	32128-001 (1)
32	Fuse block	50836-020 (2)
33	Fuse type FLNR-40 250V	41280-003 (4)
34	Terminal block	51243-002 (1)

GRILL ATTACHMENT

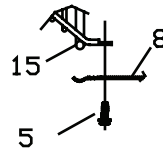

THERMOSTAT

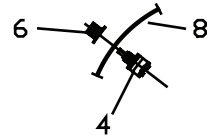

ROTATING STOP

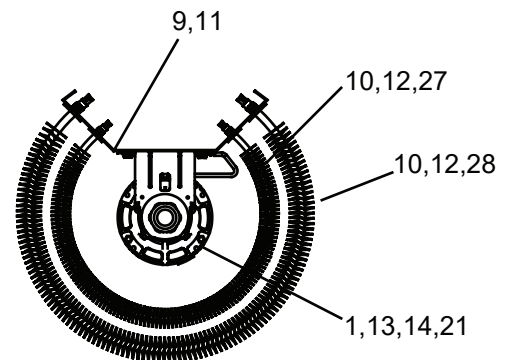
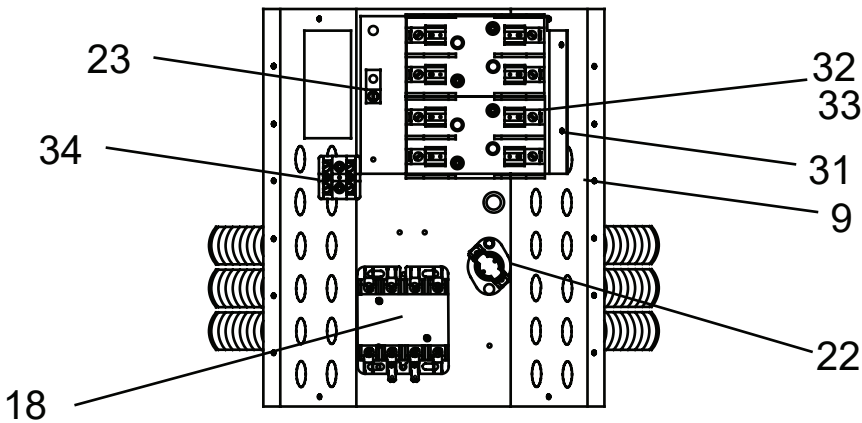
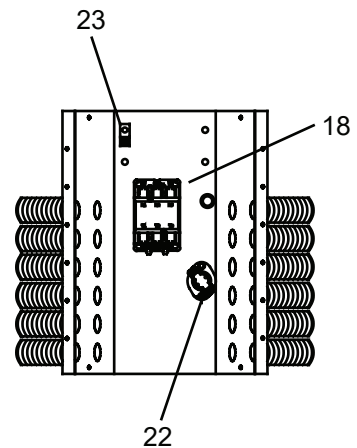
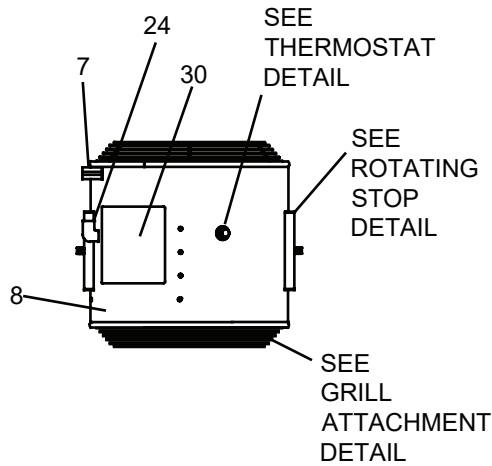
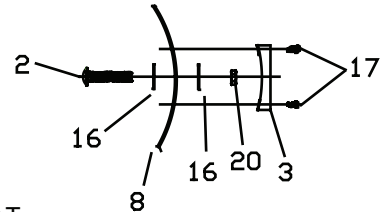

FES REPLACEMENT PARTS LIST & EXPLODED VIEWS

Ref No.	Description	Part No.
1	Handle	32117-001
2	Washer flat ¼	436258-005
3	Screw ¼-20 x 2-3/4	43893-008
4	Nut stop ¼-20	43894-001
5	Axle	58649-001
6	Cap plug	32109001
7	Leg	32117-002
8	Washer rubber	32123-001
9	Spacer	32120-001
10	Washer flat ½	32142-001
11	Wheel	58648-001
12	Push nut	54877001
13	Bar Knob	32141-01
14	Spacer	32106-001
15	Washer lock ¼	1036
16	Screw ¼-20 x 1-3/4	32111-001

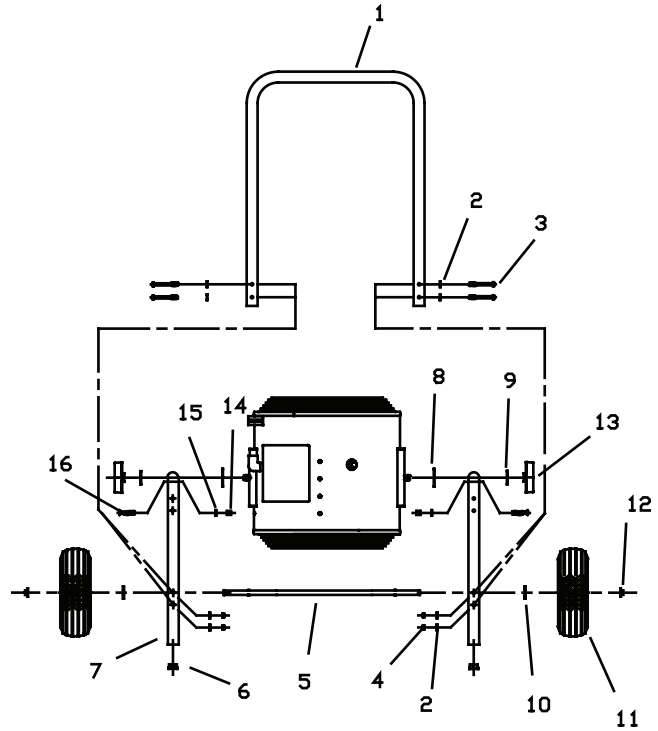

YES REPLACEMENT PARTS LIST & EXPLODED VIEWS

Ref No.	Description	Part No.	Qty.
1	Hanger	32145-003	1
2	Washer rubber	32123-001	2
3			
4	Bar knob	32141-001	2
5	Mounting bracket	57074-102	1
6	Washer fender	32142-001	4
7	Washer nylon	32143-001	1
8	Rotating stop	32144-001	1
9	Nut stop ½-13	43923-001	1
10	Screw ½-13 x 1-1/2	28953-004	1
11	Rotating Stop – Side	32146-001	2

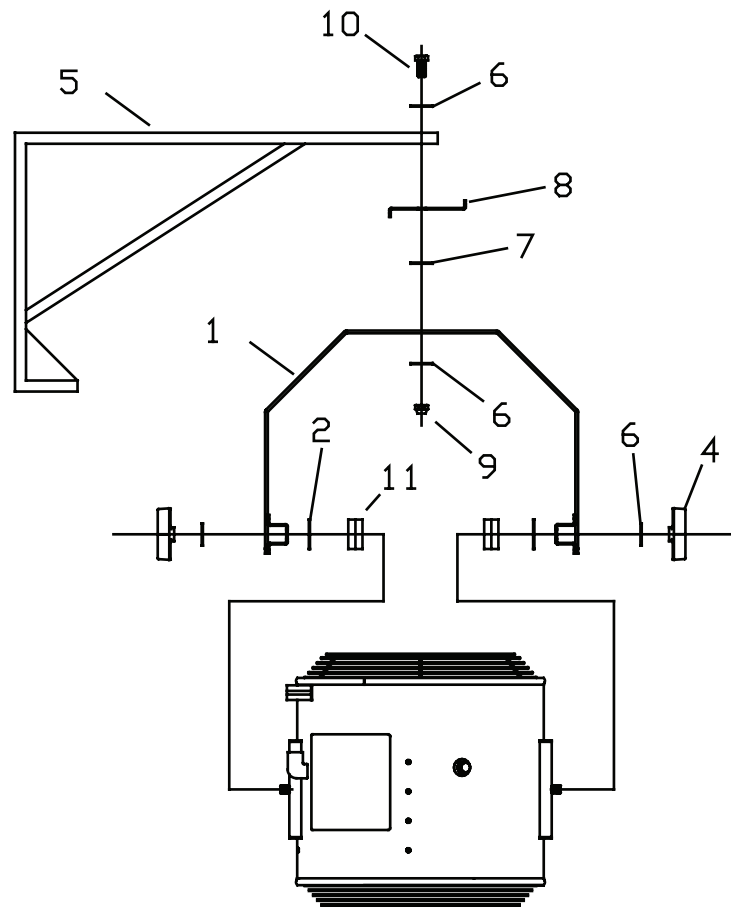

To convert an FES unit to a YES unit order the Fostoria kit Model WMK-YES p/n 04804102.

MAINTENANCE

Other than periodic cleaning of the exterior, no maintenance is required for these heaters.

- Do not hose these units down.
- Remove dust and dirt from inside heater with compressed air.
- Do not operate these heaters without the grills or the wiring compartment cover in place.
- Replace or repair feeder cable or cord set if visible damage is observed.
- Motor bearings are permanently lubricated.

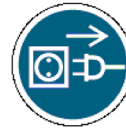

⚠ WARNING

⚠ AVERTISSEMENT

**ELECTRICAL SHOCK HAZARD
RISQUE DE CHOC ÉLECTRIQUE**

- **Serious injury or death may occur.**

Blessures graves ou la mort.

- **Disconnect from electrical supply before servicing or cleaning these heaters.**

Déconnectez-électrique fournir avant l'entretien ou le nettoyage de ces appareils de chauffage.

- **Do not operate without grills and access covers fastened in place.**

Ne pas utiliser sans grilles et couvercles d'accès fixées en place.