

MADE IN THE U.S.A.

FSS SERIES

FLAT PANEL EMITTER
ELECTRIC IR HEATER

CUSTOMER		DATE:	
PROJECT			
LOCATION			
ARCHITECT			
ENGINEER			
CONTRACTOR			
SUBMITTED BY			
APPROVED BY			
APPROVED BY			

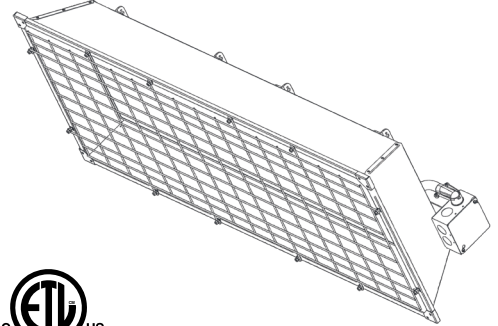

SUBMITTAL DATA SHEET

QTY	TAG	MODEL	WATTAGE	VOLTS	PHASE	AMPS

NOTES/SPECIAL INSTRUCTIONS:

- High-density, medium wavelength radiant heat, with 60° symmetric heat pattern
- Flat panel emitter operates at a radiant efficiency of 78.5%
- Non-glare, uniform heat generating directional heat pattern
- Rugged steel structure surrounds emitter element, great for high vibration areas
- Gold anodized aluminum housing for efficient, long term reflectivity & corrosion resistance
- Single or three phase wiring on select models
- “L” brackets included for chain suspension, or rigid mounting
- Field wiring box mounted on each heater
- Heavy duty wire guard factory installed
- 25,000 hour element life expectancy
- Shipped fully assembled
- Ideal for indoor spot heating, zone, or total area heating in high-bay buildings up to 24'
- Made in U.S.A.

MOUNTING HEIGHT	MFG MODEL NUMBER	LENGTH	WIDTH	COVERAGE (SQ. FT.)	WATTS (SQ. FT.)
8'	FSS-14	8	8	64	22.7
	FSS-31	9	8	72	43.8
10'	FSS-14	11	10	110	13.2
	FSS-31	11	10	110	28.6
	FSS-43	12	10	120	35.8
12'	FSS-31	12	11.5	138	22.8
	FSS-43	14	12	168	25.6
	FSS-95	15	13	195	48.7
14'	FSS-43	16	14	224	19.2
	FSS-95	18	16	288	33.0
16'	FSS-43	18	16	288	14.9
	FSS-65	19	17	323	20.1
	FSS-95	21	18	378	25.1
	FSS-95 TANDEM	24	19	456	41.7
18'	FSS-65	22	19	418	15.5
	FSS-95	23	20	460	20.7
	FSS-95 TANDEM	28	20	560	33.9
20'	FSS-95 TANDEM	28	23	644	29.5
24'	FSS-95 TANDEM	33	27	891	21.3
30'	FSS-95 TANDEM	41	32	1312	14.5

FSS/FSA Replacement Elements	
MFG CATALOG NUMBER	MFG MODEL NUMBER
01356002	64337-001
01356102	64337-002
01356202	64337-003
01356302	64337-004
01356402	64337-005
01356502	64337-006
01356602	64337-007
01356702	64337-008
01356802	64337-009
01356902	64337-010
01357002	64337-011
01357102	64337-012
01357202	64337-013
01357302	64337-014
01357402	64337-015
01357502	64337-016
01357602	64337-017
01357702	64337-018
01357802	64337-019
01357902	64337-020
01358002	64337-021

MFG CATALOG NUMBER	MFG MODEL NUMBER	WATTS	VOLTS	PHASE	BTUs / Hr.	AMPS		ELEMENTS PER HEATER	WT. (LBS)
						1-PH	3-PH		
04881502	FSS-1412-1	1450	120	1	4947	12.1		1	7
04881602	FSS-1420-1		208	1		6.97			
04881702	FSS-1424-1		240	1		6.04			
04881802	FSS-1427-1		277	1		5.23			
04881902	FSS-1448-1		480	1		3.02			
04882002	FSS-1457-1		600	1		2.52			
04882102	FSS-3120-1	3150	208	1	10,748	15.14		1	13
04882202	FSS-3124-1		240	1		13.13			
04882302	FSS-3127-1		277	1		11.37			
04882402	FSS-3148-1		480	1		6.56			
04882502	FSS-3157-1		600	1		5.48			
04882602	FSS-4320-3	4300	208	1 or 3	14,672	20.67	11.94	1	18
04882702	FSS-4324-3		240	1 or 3		17.91	10.36		
04882802	FSS-4327-1		277	1		15.52			
04882902	FSS-4348-3		480	1 or 3		8.96	5.18		
04883002	FSS-4357-3		600	1 or 3		7.48	4.32		
04926202	FSS-6520-3	6500	208	1 or 3	22178	31.3	17.1	1	28
04926302	FSS-6524-3		240	1 or 3		27.1	15.7		
04926402	FSS-6527-1		277	1		23.5			
04926502	FSS-6548-3		480	1 or 3		13.5	7.8		
04926602	FSS-6557-3		600	1 or 3		11.3	6.5		
04883102	FSS-9520-3	9500	208	1 or 3	32,414	45.67	26.39	1	31
04883202	FSS-9524-3		240	1 or 3		39.6	22.89		
04883302	FSS-9527-1		277	1		34.3			
04883402	FSS-9548-3		480	1 or 3		19.8	11.44		
04883502	FSS-9557-3		600	1 or 3		16.5	9.54		
04883602	FSS95TMK		TANDEM MOUNTING KIT						

FSS-14, FSS-31

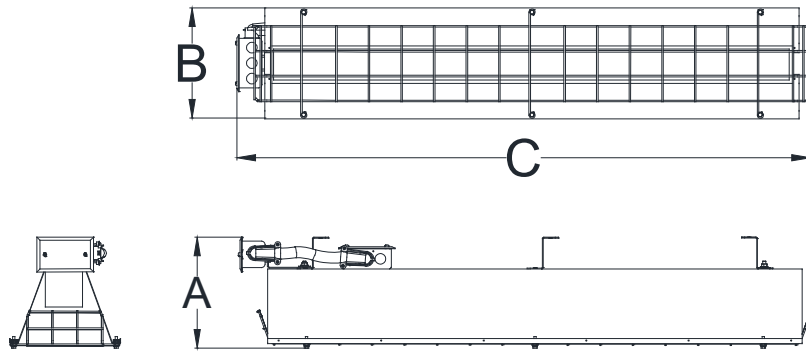

FSS-43, FSS-65 & FSS-95

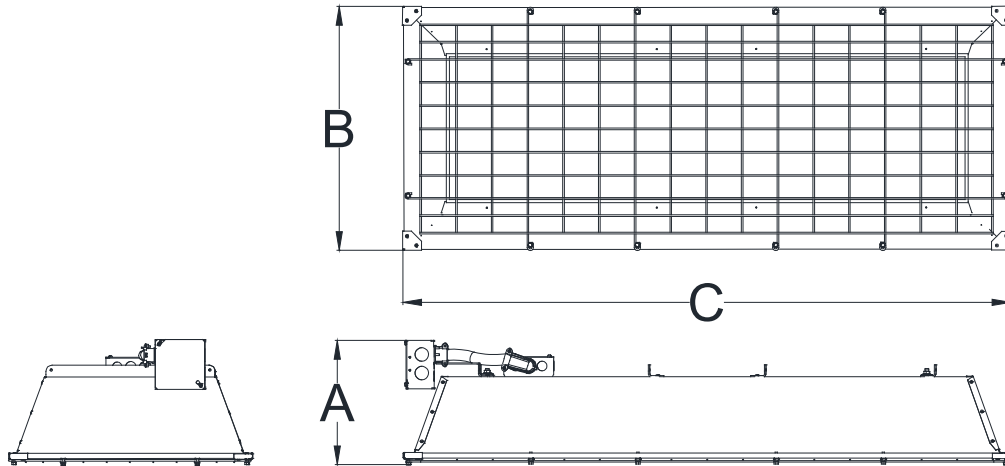

MFG MODEL NUMBER	DIMENSIONS (IN.)		
	"A" DEPTH	"B" WIDTH	"C" LENGTH
FSS-14	8 ½	9	26
FSS-31	8 ½	9	46
FSS-43	9 ¾	20	29
FSS-65	9 ¾	20	38
FSS-95	7 ¾	20	49
FSS-95 TANDEM	7 ¾	20	108

REQUIRED MINIMUM MOUNTING CLEARANCES		KW	RECOMMENDED MOUNTING HEIGHT
FSS-14 and FSS-31 - 6" from ceiling FSS-43, FSS-65 and FSS-95 - 24" from ceiling 36" from vertical surface & from another heater 72" from face of heater to combustible surface		1.4	8' - 10'
		3.1	8' - 12'
		4.3	10' - 14'
		6.5	10' - 15'
		9.5	12' - 16'
FSS-95 Tandem Only	87" from face of heater to combustible surface	(2) 9.5	15' - 30'