

INSTALLATION AND OPERATION INSTRUCTIONS
303, 304, 305, CRH, CRQ, CFA SERIES
2250 WATT MODELS

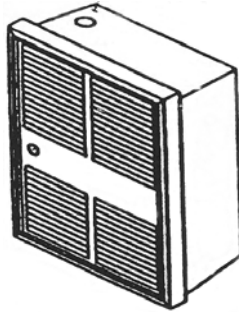

Caution: To prevent electric shock disconnect power to heater at main service before wiring or service.

Caution: Do not obstruct the front of the heater with curtains, furniture, doors, etc. Do not place heaters under towel racks. Proper operation of the heater requires a free flow intake and exhaust of air.

WARNING: To insure proper operation, all heaters must be thermostatically controlled.

GENERAL

These heaters are designed for 2 X 4 recessed or surface mount installation. The heaters may be wall mounted in a vertical position with bottom discharge, or horizontal position and ceiling mounted. The minimum clearance from wall box to adjacent wall or floor is 6 inches. These heaters must not be installed without wall box model no. 30WB.

INSTALLATION OF WALL BOX 30 WB FOR NEW CONSTRUCTION

1. Position wall box a minimum of 6 inches from adjacent wall and floor. Secure to wall stud with nails or screws. Wall box must be installed with front edge flush with finished wall surface. See figure 1.
2. Remove knockout in wall box for power source, and install cable clamp.
3. Insert supply cable through clamp allowing 6-8" for field wiring.

NOTE: Field wiring must enter wall box where the corner wiring compartment is located.

INSTALLATION OF WALL BOX 30WB FOR EXISTING CONSTRUCTION

1. Carefully cut a hole measuring 9 1/4" wide by 12 1/4" long in wall. Wall box 30WB must be attached to a wall stud on one edge. Minimum clearances of 6" must be maintained to adjacent surfaces. Attach wall box and secure power cable as in new construction.

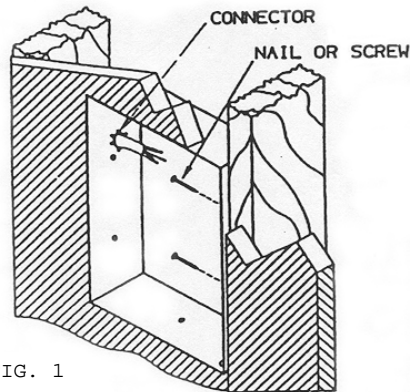

FIG. 1

NOTE: IN THE VERTICAL POSITION THE HEATER CAN BE MOUNTED ONLY FOR BOTTOM DISCHARGE.

FIELD CONVERSION FOR LOWER WATTAGE

To convert heater to a lower wattage rating, see Fig. 2.

INSTALLATION OF HEATER ASSEMBLY

1. Place heater into wall box and secure with the two no. 8 X 1/2 screws provided.
2. Connect power supply to heater pigtails with wire nuts or crimp terminals.
3. After field connections are made, push wires into wiring compartment and secure wiring compartment cover to heater using no. 8 X 1/2" screw provided.

INSTALLATION OF GRILLE AND KNOB

1. Place the two no. 8 oval head screws into grille mounting holes.
2. Align grille with heater and secure. Be careful not to over tighten as this may cause fan blade to strike grille.
3. To install knob, remove hole plug in grille and align flat of thermostat shaft with flat on knob. Push knob onto shaft until knob almost touches grille.
4. For tamper-resistant installation, set thermostat with knob, remove knob and replace hole plug. Retain knob for future use.

OPERATION

1. Turn on the power supply to heater.
2. Rotate thermostat knob fully clockwise. This heater is equipped with a fan delay, so the fan will be delayed 45-60 seconds after the element is energized.
3. Allow the room to reach desired temperature, then rotate thermostat knob counter clockwise until thermostat clicks. Fan will continue to run for 45-60 seconds to purge warm air from heater enclosure. The heater will continue to cycle on and off in the selected temperature range.
4. For remote thermostat operation, remove wire nut on wires marked T1 and T2. Connect single pole remote thermostat to T1 and T2. Thermostat wiring must be the same size as power supply wiring. See specification chart for minimum wire size.

NOTE: The wall thermostat cycles the heating element only. Direct runs of supply service leads L1 and L2 supplies continuous power to the fan motor, and the heater should be considered live at all times. Move the disconnect switch to the off position or disconnect power at main distribution box before any maintenance work. Turning the thermostat to low position will not disconnect the heater.

WARNING: It should be noted that the 3000 series units feature a fan delay control to allow for element pre-heat and more critically fan purge of heat at the end of thermostat cycle. If the units are turned off with disconnect while the motor is operating, the residual heat may allow the manual reset thermal limit to cycle, this may lead to service calls and unnecessary returns of the units. To turn these units off with the disconnect switch, the thermostat should first be turned to low position, fan should be allowed to complete the purge cycle. These units have a label attached that states “ DO NOT DISCONNECT UNIT WHILE FAN IS RUNNING”. This applies to any unit that has the disconnect option.

NOTE: This heater is equipped with a manual reset limit control. The front grille must be removed to reset limit. Disconnect power before reset button is pushed.

SPECIFICATIONS

MODEL NO.	VOLTS	WATTAGE *	BTU/HOUR	AMPERAGE	MIN. ** WIRE SIZE 60°C
F30322, CRH822 F30422, CPQ822 F30522, CFA822	208	500, 750, 1000 1250, 1500, 1750 2250	1707, 2560, 3413, 4266, 5120, 5973 7680	10.8	14 AWG.
H30322, CRH222 H30422, CPQ222 H30522, CFA222	240	500, 750, 1000 1250, 1500, 1750 2250	1707, 2560, 3413, 4266, 5120, 5973 7680	9.4	14 AWG.

* Factory wired for higher wattage, field convertible to lower wattage.

** Use copper wire only. All wiring must conform to N.E.C. and local electric codes.

FIG. 2 WATTAGE CONVERSION CHART

	<p>WD-1 2250W</p>	<p>WD-2 1750W Remove orange jumper. WD-3 1500W Remove red jumper and move orange jumper to terminal "A". WD-4 1250W Remove red jumper, remove wires from terminal "A" to terminal "B". Connect orange jumper to terminals "B" and "C". WD-5 1000W Remove orange and red jumpers. Move wires from terminal "A" to "B". WD-6 750W Remove orange and red jumpers. WD-7 500W Remove orange and red jumpers. Move wires from terminal "A" to "C".</p>	
	<p>WD-2 1750W</p>		<p>WD-3 1500W</p>
	<p>WD-4 1250W</p>		<p>WD-5 1000W</p>
	<p>WD-6 750W</p>		<p>WD-7 500W</p>

"T" OPTION

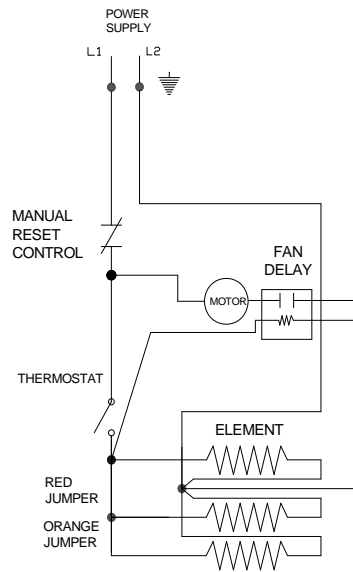

"T2" OPTION

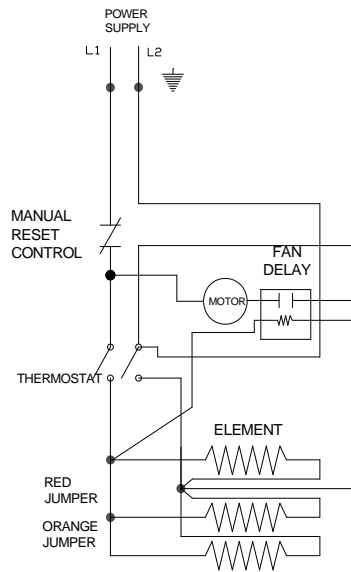

"TD" OPTION

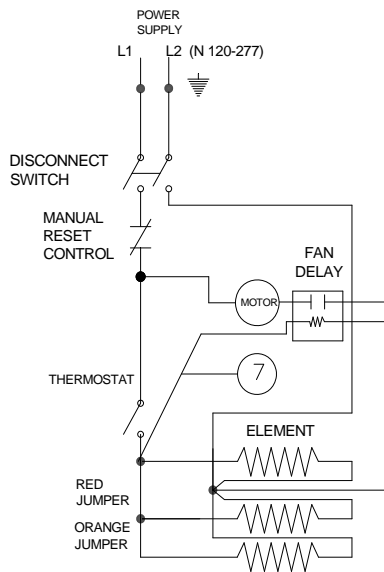

"T2D" OPTION

