



TPI
CORPORATION
America's Comfort Conditioning Company

2024

Electrical Products Catalog

Electric Heat - Controls - Thermostats

CONTROLS

HEATING



TEL: 1-800-682-3398 | www.tpicorp.com | productsearch.tpicorp.com
© Copyright 2024 ; REV: 03152024

Table Of Contents

CATEGORY	PAGE
AMPERAGE CHART & WARRANTY	2
ELECTRIC HEAT COMFORT ZONES	3
HAZARDOUS LOCATION & WASHDOWN	
HLA*	Hazardous Location Fan Forced 4-7
PHLA*	Portable Hazardous Location Fan Forced 7
FEP*	Hazardous Location Convactor 8-9
5500*	Washdown Fan Forced 10-11
UNIT HEATERS	
UH	Horizontal Fan Forced 12-13
UHE	Horizontal Fan Forced 14-15
5100	Horizontal or Vertical Fan Forced 16-21
2600	Downflow Fan Forced 22-23
5700	Confined Space Plenum Rated 24
5600	Multiple Wattage Fan Forced 25
6300	Cabinet Fan Forced 26-29
WALL CONVECTORS	
8500*	Commercial Slope Top 30-31
8800*	Institutional 32-33
4100*	Recessed Commercial 34-35
CEILING & COVE	
3000	Fan Forced 36
3380	Commercial Fan Forced 36
3480*	Commercial Recessed Fan Forced 37-38
3370*	Commercial Surface Fan Forced 39
3340	Heavy Duty Recessed Fan Forced 40
CP/RCP	Radiant Ceiling Panel 41
CVX	Radiant Cove 42
WALL HEATERS	
305	Commercial Midsized Fan Forced 43
4400	Commercial Low Profile Fan Forced 43
3340	Heavy Duty 44-45
3320	Commercial Fan Forced 46-47
3420/50	Heavy Duty Fan Forced; Setback 48-50
3310	Residential/Commercial Fan Forced 51-53
3200	Midsized Fan Forced 54
4300	Low Profile Fan Forced 55
4800	Register Style Fan Forced 56
ARCHITECTURAL SILL LINE	
	General Product Information 57
9100*	Radius Front Draft Barrier 58-60
9300*	Radius Front Draft Barrier 61-62
DBF/DBT*	3 1/8" x 4 1/2" Convactor 63
RDBT*	7" x 6" Convactor (Round) 64
ASHDB*	5 1/2" x 8" thru 20" Tall Convactor 65
9900*	Commercial/Industrial Floor Heater 66-70
BASEBOARD HEATERS	
3900	Hydronic Electric 71
3700	Architectural Style Electric 72
	Hydronic/Architectural Accessories 73-74
2900S	Stainless Steel Element Electric 74-75
2900C	Heavy Duty Commercial Electric 76
	Electric Baseboard Accessories 77
ELECTRIC INFRARED HEATERS	
TH, THSS, & THA	Mul-T-Mount 78-87
	Mul-T-Mount Accessories 88
FSS	Heavy Duty Flat Panel Emitter 90-91
FSA	Architectural Flat Panel Emitter 92-93
OCH, OCH2	Outdoor/Indoor Rated Quartz 94-96
RPH	Outdoor Rated Stainless Steel 97
MM	Mitey Midget 97
FFH	Utility Infrared Heater 97

Note: The information contained herein is deemed to be as accurate as possible upon the time of printing. However, to ensure that you receive the most reliable information contact the factory should a question arise. Prices subject to change without notice. All prices are given in U.S. Dollar Amounts.

PH: 1-800-682-3398. © Copyright 2024; TPI Corporation.

CATEGORY	PAGE
ELECTRIC INFRARED HEATERS, CONTINUED	
	Elements, Accessories, & Controls 98-99
ICP*	ICP Control Panels 100-101
FPC	FPC Control Panels 102
FSP	Heavy Duty Flat Panel Emitter 103
PCH	Portable Quartz Infrared Spot Heater 104
RHG	Portable Infrared Instant "On-Off" Heat Gun 104
HP	Portable Electric Infrared Heat Panels 104
PORTABLE HEATERS	
FES & YES	Salamander Heat Wave™ 105-106
150-TS	120V Electric Portable Heater 107
198	120V Fan Glo 107
188	120V Milk House 108
E3915	120V Hydronic Baseboard 108
483	120V Baseboard 108
474	240V Dual Heat Fan Forced 109
5800	240V Garage/Workshop 109
ICH	240V Construction/Utility 109
680	240V Heavy Duty 110
SPECIALTY HEATERS	
RPH	Pump House 110
FH	In-Floor Fan Forced 111
TSH	Kick-Space Fan Forced 111
AIR CURTAIN	
CF-C	2 Speed Commercial Air Curtain 111
CF/CFH*	Variable Speed Air Curtain 112
THERMOSTATS	
ET9	Line Voltage, 22A, 277VAC 113
EPET / HLT	Line Voltage, Haz. Loc., 120-277VAC 113
2000	Line Voltage, 22A, 120-277VAC 113
TW	Line Voltage, 120-277VAC 114
CKT / KT	Line Voltage, 120-250VAC 114
T	Line Voltage, Precision, 120-277VAC 115
TL	Line Voltage, Programmable 115
UT	Low Voltage, Vertical/Horizontal Mnt. 115
RK	Low Voltage, Square 115
PRO1	Digital Non-Programmable Multi-Stage 116
L	Line Voltage, 25A, 250VAC 116
24A	Low Voltage Relays 116
H	Humidistat/DeHumidistat, 24-240VAC 117
LB	Bi-Metal In-Built 117
LR	Bi-Metal Outdoor 117
RH	Air Flow / Differential Pressure Switches 118
	Differential Pilot Tubes 118
TG	Thermostat Guards 118
THERMAL AREA TREATMENT	
TAT	Thermal Area Treatment/Accessories 119
HR	Hot Room Heaters 119
DUCT HEATERS	
HP*	HotPod Resi. Supplemental Duct Heat 120-121
5700	Confined Space Plenum Rated 122
7200/7300*	Plenum Heaters & Accessories 122-125
PD*	Packaged (preconfigured) Duct Heat 126
PRODUCT INDEX	

* Products listed in this section are custom built and subject to 100% cancellation/restocking charges

Amperage Chart & Electric Heat Products Limited Warranty

K.W Rating	B.T.U.H.	208 Volt AMP Rating		220 Volt AMP Rating		230 Volt AMP Rating		240 Volt AMP Rating		277 Volt AMP Rating	440 Volt AMP Rating	480 Volt AMP Rating	550 Volt AMP Rating
		1 PH	3 PH	1 PH	3 PH	1 PH	3 PH	1 PH	3 PH	1 PH	3 PH	3 PH	3 PH
00.5	1,706	2.4	1.4	2.3	1.3	2.2	1.3	2.1	1.2	1.8	0.6	0.6	0.5
01.0	3,413	4.8	2.8	4.5	2.6	4.3	2.5	4.2	2.4	3.6	1.3	1.2	1.0
02.0	6,826	9.6	5.5	9.1	5.2	8.7	5.0	8.3	4.8	7.2	2.6	2.4	2.1
03.0	10,239	14.4	8.3	13.6	7.9	13.0	7.5	12.5	7.2	10.8	3.9	3.6	3.1
04.0	13,652	19.2	11.1	18.2	10.4	17.5	10.1	16.6	9.6	14.4	5.2	4.8	4.2
05.0	17,065	24.0	13.8	22.7	13.1	21.7	12.6	20.8	12.0	18.1	6.6	6.0	5.2
06.0	20,478	28.8	16.6	27.3	15.7	26.1	15.1	25.0	14.4	21.7	7.9	7.2	6.3
07.0	23,891	33.6	19.4	31.8	18.4	30.4	17.6	29.1	16.8	25.3	9.2	8.4	7.3
08.0	27,304	38.5	22.2	36.4	20.9	34.9	20.1	33.3	19.2	28.9	10.5	9.6	8.4
09.0	30,717	42.8	24.9	40.9	23.3	39.1	22.6	37.7	21.4	32.5	11.8	10.8	9.5
10.0	34,130	48.1	27.4	45.4	26.2	43.5	25.1	41.7	24.0	36.1	13.2	12.0	10.5
11.0	37,543	52.9	30.5	50.0	28.6	47.8	27.6	45.8	26.4	39.7	14.5	13.2	11.6
12.0	40,956	57.7	33.2	54.5	31.5	52.1	30.2	50.0	28.6	43.3	15.8	14.4	12.6
13.0	44,369	62.5	36.0	59.1	34.1	56.9	32.7	54.2	31.3	46.9	17.1	15.6	13.7
14.0	47,782	67.3	38.8	63.6	36.7	60.9	35.2	58.3	33.7	50.5	18.4	16.8	14.7
15.0	51,195	72.1	41.5	68.2	39.1	65.2	37.7	62.5	35.1	54.2	19.8	18.0	15.8
16.0	54,608	76.9	44.3	72.7	41.9	69.6	40.2	66.7	38.5	57.8	21.1	19.2	16.9
17.0	58,021	81.7	47.1	77.3	44.3	73.9	42.7	70.8	40.9	61.4	22.4	20.4	17.9
18.0	61,434	86.5	49.8	81.8	47.2	78.3	45.2	75.0	43.3	65.0	23.7	21.6	19.0
19.0	64,847	91.3	52.6	86.4	49.6	82.6	47.7	79.2	45.7	68.6	25.1	22.8	20.0
20.0	68,260	96.1	55.1	90.9	52.5	86.9	50.3	83.3	48.1	72.2	26.4	24.0	21.1
21.0	71,673	100.0	58.2	95.6	55.1	91.3	52.9	87.5	50.5	75.8	27.7	25.2	22.1
22.0	75,086	105.8	60.9	100.0	57.7	95.7	55.3	91.7	52.9	79.4	29.0	26.4	23.1
23.0	78,499	110.6	63.7	104.5	60.4	100.0	57.9	95.8	55.3	83.0	30.3	27.6	24.3
24.0	81,912	115.4	66.5	109.1	62.9	104.3	60.3	100.0	57.7	86.6	31.7	28.8	25.3
25.0	85,325	120.2	69.2	113.6	65.3	108.6	62.8	104.1	60.1	90.3	33.0	30.1	26.4
26.0	88,738	125.0	72.0	118.2	68.3	113.0	65.3	108.3	62.5	93.9	34.3	31.3	27.4
27.0	92,151	129.8	74.8	122.7	70.9	117.4	67.8	112.5	64.7	97.5	35.6	32.5	28.5
28.0	95,564	134.6	77.2	128.2	73.5	121.7	70.3	116.6	67.3	101.1	36.9	33.7	29.5
29.0	98,977	139.4	80.3	131.8	76.0	126.0	72.9	120.8	69.7	104.7	38.3	34.9	30.6
30.0	102,390	144.2	83.1	136.4	78.7	130.4	75.4	125.0	72.1	108.3	39.6	36.1	31.7
31.0	105,803	149.0	85.9	140.9	81.3	134.7	77.9	129.2	74.5	111.9	40.9	37.3	32.7
32.0	109,216	153.8	88.7	145.4	83.9	139.0	80.4	133.4	76.9	115.5	42.2	38.5	33.8
33.0	112,629	158.6	91.5	149.9	86.5	143.3	82.9	137.6	79.3	119.1	43.5	39.7	34.8
34.0	116,042	163.4	94.3	154.4	89.1	147.6	85.4	141.8	81.7	112.7	44.8	40.9	35.9
35.0	119,455	168.2	97.1	158.9	91.7	151.9	87.9	146.0	84.1	126.4	46.1	42.1	36.9
36.0	122,868	173.0	99.9	163.4	94.3	156.2	90.4	150.2	86.5	130.0	47.4	43.3	38.0
37.0	126,281	177.8	102.7	167.9	96.9	160.5	92.9	154.4	88.9	133.6	48.7	44.5	39.0
38.0	129,694	182.6	105.5	172.4	99.5	164.8	95.4	158.6	91.3	137.2	50.0	45.7	40.1
39.0	133,107	187.4	108.3	176.9	102.1	169.1	97.9	162.8	93.7	140.7	51.3	46.9	41.1
40.0	136,520	192.2	111.1	181.4	104.7	173.4	100.4	167.0	96.1	144.4	52.6	48.1	42.2
41.0	139,933	197.0	113.9	185.9	107.3	177.7	102.9	171.2	98.5	148.0	53.9	49.3	43.2
42.0	143,346	201.8	116.7	190.4	109.9	182.0	105.4	175.4	100.9	151.6	55.2	50.6	44.3
43.0	146,759	206.6	119.5	194.9	112.5	186.3	107.9	179.6	103.3	155.2	56.5	51.8	45.3
44.0	150,172	211.4	122.3	199.4	115.1	190.6	110.4	183.8	105.7	158.8	57.8	53.0	46.4
45.0	153,585	216.2	125.1	203.9	117.7	194.9	112.9	188.0	108.1	162.5	59.1	54.2	47.4
46.0	156,998	221.0	127.9	208.4	120.3	199.2	115.4	192.2	110.5	166.1	60.4	55.4	48.5
47.0	160,411	225.8	130.7	212.9	122.9	203.5	117.9	196.4	112.9	169.7	61.7	56.6	49.5
48.0	163,824	230.6	133.5	217.4	125.5	207.8	120.4	200.6	115.3	173.3	63.0	57.8	50.6
49.0	167,237	235.4	136.3	221.9	128.1	212.1	122.9	204.8	117.7	176.9	64.3	59.0	51.6
50.0	170,650	240.2	139.1	226.4	130.7	216.4	125.4	209.0	120.1	180.5	65.6	60.2	52.7
51.0	174,063	245.0	141.9	230.9	133.3	220.7	127.9	213.2	122.5	184.1	66.9	61.4	53.7
52.0	177,476	249.8	144.7	235.4	135.9	225.0	130.4	217.4	124.9	187.7	68.2	62.6	54.8
53.0	180,889	254.6	147.5	239.9	138.5	229.3	132.9	221.6	127.3	191.3	69.5	63.8	55.8
54.0	184,302	259.4	150.3	244.4	141.1	233.6	135.4	225.8	129.7	194.9	70.8	65.0	56.9
55.0	187,715	264.2	153.1	248.9	143.7	237.9	137.9	230.0	132.1	198.6	72.2	66.2	57.9
56.0	191,128	269.0	155.9	253.4	146.3	242.2	140.4	234.2	134.5	202.2	73.5	67.4	58.8
57.0	194,541	273.8	158.7	257.9	148.9	246.5	142.9	238.4	136.9	205.8	74.9	68.6	59.9
58.0	197,954	278.6	161.5	262.4	151.5	250.8	145.4	242.6	139.3	209.4	76.2	69.8	60.9
59.0	201,367	283.4	164.3	266.9	154.1	255.1	147.9	246.8	141.7	213.0	77.5	71.0	62.3
60.0	204,780	288.2	167.1	271.4	156.7	259.4	150.4	251.0	144.1	216.6	78.8	72.2	63.0

Note: All custom built products are subject to 100% cancellation/restock charges.

In addition to the Limited Warranty stated to the right covering general products, TPI Corporation extends this warranty on the following listed products, which are warranted to the original consumer from the original date of purchase for the total time periods indicated herein below:

Heat Products	
Elements in 2900 Series Baseboard	10 Years
All Other Heating Products	1 Year
Thermostats & Controls	2 Years

TPI Corporation provides a limited warranty of materials and workmanship for a period of (i) ten (10) years for elements in 2900 Series baseboard heaters, (ii) two (2) years for Thermostats and Controls, (iii) five (5) years on HD and HDH series fans, (iv) three (3) years on UHP and IHP series fans, (v) and twelve (12) months for all other products, with the warranty period commencing on the original date of purchase. The TPI warranty is limited to materials manufactured and work performed by TPI Corporation, and does not include damage or failure caused by acts of God, abuse, misuse, connected to or placed on other than rated voltage, abnormal usage, faulty installation, failure to follow suggested maintenance procedures enclosed with the product, improper maintenance or any repairs other than those provided by an authorized TPI Corporation service center. For the name of your nearest authorized TPI Corporation service center, please write to TPI Corporation, P.O. Box 4973, Johnson City, Tennessee, 37602 or call 1-800-682-3398.

During the warranty period, TPI Corporation will, at its sole option, repair or replace any defective parts or products returned, freight prepaid, to the TPI Corporation factory or such other location as TPI Corporation may designate. No parts or products will be accepted for repair or replacement without prior authorization from TPI Corporation and a return merchandise authority (RMA) number issued by TPI Corporation. Returned products must be packaged carefully and TPI Corporation shall not be responsible for damage in transit. When returning parts, the owner must provide the model number of the product and nature of difficulty being experienced.

This warranty does not obligate TPI Corporation to bear the cost of labor in replacing any assembly, unit or component part thereof, nor does TPI Corporation assume any liability for secondary charges, expenses for installing or removal, freight or damages. There will be charges rendered for product repairs made after the warranty period has expired. Proof of purchase, including date, must accompany request for in-warranty service. This warranty gives you specific legal rights and you may have other rights, which may vary, from state to state.

Except for the limited warranty provided in the foregoing paragraph, all parts and products sold by TPI Corporation are sold 'as is', 'where is', and without any other warranty of any kind or nature, whether express, implied, or statutory and including, without limitation, any implied warranty of specific performance or merchantability.

Under no circumstances, even with respect to claims covered by the foregoing warranty, will TPI Corporation be responsible for any incidental, consequential, special, or punitive damages of any kind or nature arising from or related to the parts or products sold by TPI Corporation.

In any event, TPI Corporation's maximum liability shall not in any case exceed the purchase price for the part or product claimed to be defective.

You hereby expressly agree to waive any and all rights to a trial by jury with respect to any product manufactured or supplied by TPI Corporation.

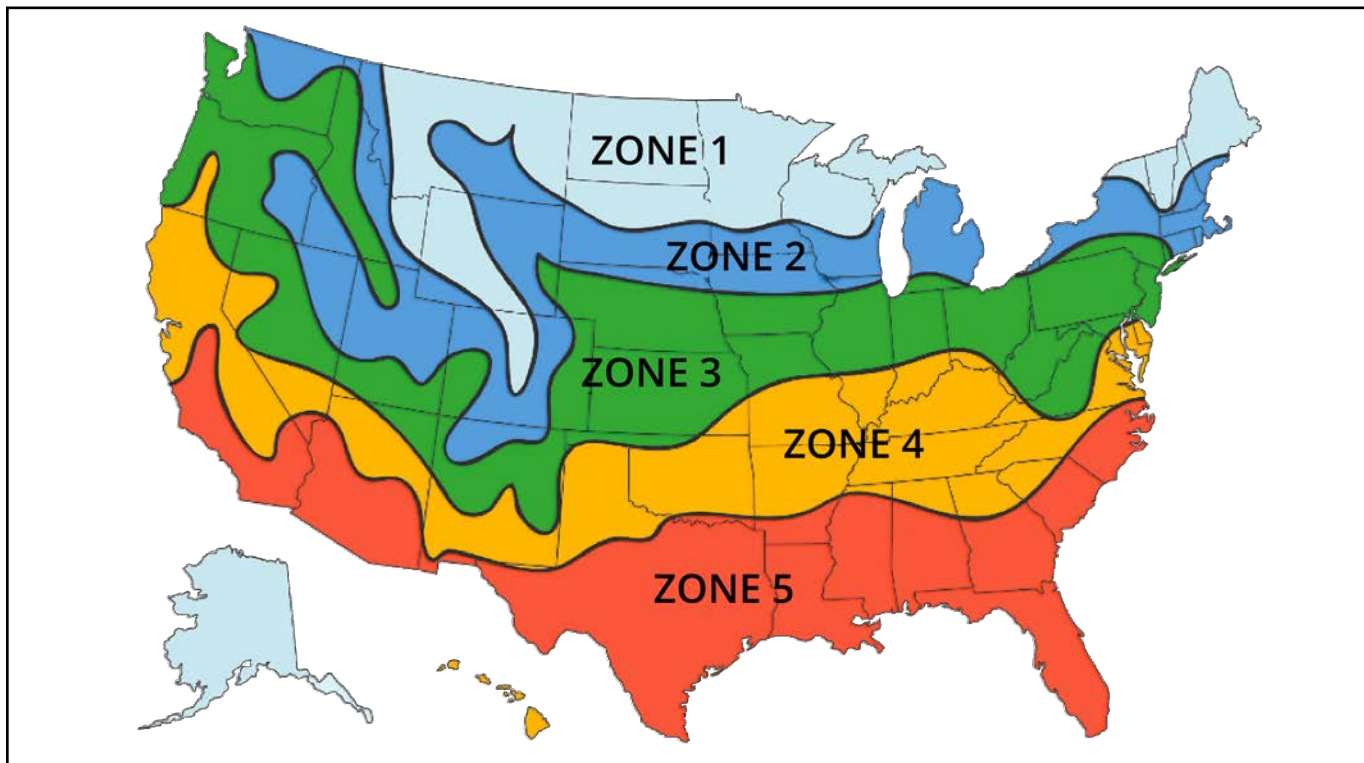

INSULATION			
R-VALUE	Recommended	FHA Standard	Minimum: Not Recommended
Ceiling	*R-24	*R-19	*R-11
Walls	R-13	11	R-7
Floor	R-24	11	----
ZONE	APPROXIMATE WATTAGE NEED PER SQUARE FOOT		
1	8.6	10.0	14.6
2	7.7	9.0	13.1
3	7.1	8.2	12.0
4	6.4	7.4	10.8
5	6.0	7.0	10.2

*"R" values are industry standards for insulation effectiveness. Ask company representative for assistance if you do not know "R" for your present structure insulation.

Baseboard or wall mount style? Recessed or surface type? It's easy to select the heater that's right for you.

- Measure the size of the room(s) or area you intend to heat for square footage.
- You will need the length times the width to get this calculation.
- Find your location on the map above. This determines your basic heating zone. The chart shown below the map lists insulation values based on the effectiveness of the insulation presently in your home.
- Find your heating zone on the chart and the approximate wattage per square foot you will need.
- Multiply the total number of square feet you intend to heat by the approximate wattage per square foot you just obtained. This will determine your total heating requirement in watts for the room.

How Much Heat is Right For You?

Figures are based on 15% total window and door openings in outside walls, and 3/4 total home air changes per hour. Typical frame-type construction with unheated basement or unventilated crawl space. If you do not have storm doors and windows, add 30% to the watts per square foot (multiply by 1.3).

That's all there is to it! Now choose the heater with a wattage equal to what you need. Your final selection will, of course, depend on available wall space, window placement, ect.

Example Calculation: 10' x 12' room in Zone 3 with FHA standard insulation

1. Determine room square footage: 10' x 12' = 120 sq. ft.
2. Zone 3 with FHA standard insulation requires 8.2 watts per sq. ft.
3. Multiply square footage of room to be heated by the approximate wattage per square foot required. 120 sq. ft x 8.2 watts = 984 watts required. From this calculation it can be reasoned that a 1000 watt heater would be required.

HLA Series Hazardous Location Fan Forced Unit Heater

FAN-FORCED SUSPENDED UNIT HEATERS 3-25 KW FOR T-3B CLASS I, GROUP C & D, DIVISION 1 & 2 AND CLASS II, GROUPS E, F & G, DIVISIONS 1 & 2.

4

Shown with optional pilot light and disconnect switch



WARNING: This product can expose you to chemicals including nickel which is known to the State of California to cause cancer, and chromium, which is known to the State of California to cause birth defects and/or reproductive harm. For more information go to www.P65Warnings.ca.gov.



- Designed for rugged industrial applications in hazardous locations where the possibility of explosion or fire exists due to the presence of certain flammable gases, vapors, powdered metals or dust
- Permanently sealed, liquid to air, finned tube heat exchanger core
- Ethylene Glycol to water mixture used as a heat transfer fluid in the heater core, providing -45° C. (-49° F) freeze damage protection
- High-performance electric motor driven fan blows air across finned tubes to effect uniform heat transfer and area heat distribution
- Manual Reset capillary type limit provides high temperature regulation and is rated for 6,000 cycles of service
- Stainless steel and aluminum pressure relief valve for overpressure
- A back-up contactor is included for additional protection
- 14 gauge steel cabinet powder coated epoxy paint finish contains heater core, motor, and fan assembly
- Narrow gap safety fan guard shields all moving parts
- Adjustable louvers allow directional control of air
- Copper conductor wires enclosed in rigid metal conduits carry all electrical power
- Box lugs furnished for field connections within approved enclosure
- Made in U.S.A.

Product Specifications

Heat Exchanger and Elements:

Heavy walled, painted carbon steel with aluminum fins liquid heat exchanger, liquid filled with three-immersion type copper sheathed elements. The elements shall have the highest quality nickel-chromium resistance wire encased in a magnesium oxide dielectric and be hermetically sealed into the heat exchanger core. The heat transfer fluid is Ethylene-glycol solution for operation to -49 degrees F (-45 degrees C). Stainless steel and aluminum pressure relief valve for overpressure.

Thermal Cutout High Limit Protection and Optional Pilot Light:

The capillary type manual reset thermal cutout shall be rated for 6000 cycles of service and mounted in the liquid filled heat exchanger. An optional pilot light to indicate power on is located on control enclosure.

Motor:

The motor shall be a permanent split capacitor type, permanently lubricated, ball bearing type. The motor shall be rated for hazardous location and operate at rated voltage of heater, 60 Hz, 1725 RPM.

Control Enclosure:

All controls shall be factory installed and wired in a hazardous location enclosure. Contactors and back-up contactors are heavy duty type and break all ungrounded conductors and be rated for 100,000 cycles at full load. Standard 24-Volt control circuit shall be supplied by internal class II transformer. An optional factory wired integral thermostat or standard terminal block for field wiring to optional remote wall thermostat are wired in control panel. No fan delay relay.

Disconnect Switch:

Factory mounted and wired hazardous location disconnect switch is available as optional accessory.

Cabinet With Adjustable Louvers:

The Cabinet shall be 14 gauge, cold rolled steel with powder coated epoxy finish. Plated fan guards with less than ¼ inch spacing to cover motor and fan shall conform to OSHA Requirements.

Note: Before selecting a hazardous location electric heater refer to Article 500 or other applicable standard referenced in the National Electric Code.



Liquid-to-air heat exchanger



Optional built-in thermostat



Hazardous Location Rated Motor

HLA Series Hazardous Location Fan Forced Unit Heater

Rating Definitions

CLASS I: Equipment does not have surface operating temperature in excess of the ignition temperature of the specific gas or vapor.

Application Examples:

- Offshore and land based drilling rigs, petroleum exploration and testing facilities
- Petroleum refineries, gasoline storage and dispensing areas
- Industrial firms that use flammable liquids in dip tanks for parts cleaning or other operations
- Petrochemical companies that manufacture chemicals from gas or oil
- Dry cleaning facilities where vapors from cleaning fluids may be present
- Aircraft hangers and fuel servicing areas
- Utility gas plants and operations involving storage and handling of liquefied petroleum or natural gas

GROUP C: Atmospheres such as but not limited to acetaldehyde, allyl alcohol, hydrogen sulfide, ethylene, carbon monoxide, or other gases or vapors of equivalent hazard.

GROUP D: Atmospheres such as but not limited to acetone, alcohol, gasoline, lacquer solvent vapors, natural gas, propane or other gases or vapors of equivalent hazard.

CLASS II: Equipment does not have surface temperature greater than the ignition temperature of the specified dust.

Application Examples:

- Coal preparation plants and other carbon handling or processing areas
- Grain elevators, flour and feed mills
- Plants which manufacture, use or store Magnesium or Aluminum powders
- Plants that have chemical or metallurgical processes.
- Producers of starch products or candy
- Spice grinding plants, sugar plants and cocoa plants

GROUP E: Atmosphere containing combustible metal dust regardless of resistivity, or other combustible dust of similar hazard characteristics having resistivity of less than 10⁵ OHM - Centimeter.

GROUP F: Atmosphere containing carbon black, charcoal, coal or coke dust.

GROUP G: Atmospheres containing combustible dust having resistivity of 10⁵ OHM-Centimeter or greater.

DIVISION I: A location in which ignitable concentrations of flammable material exist under normal operating conditions.

DIVISION II: Locations in which flammable materials will normally be confined within closed containers and escape only in the case of accidental rupture, breakdown or during maintenance operations. Any equipment approved for Division I is automatically also approved for Division II.

Standard Hazardous Location Models

MFG CATALOG NUMBER	MFG MODEL NUMBER	KW	BTUs	VOLTS	PH	AMPS	CONTROL VOLTAGE	TEMP RISE °F	AIR THROW	CFM	Recom'd Mounting Ht.	WT. (lbs)	LIST
07343502	HLA 12-208160-3.0-24	3	10240	208	1	16.3	24	16.5	24'	580	8'	167	14860
07340002	HLA 12-208360-3.0-24	3	10240	208	3	9.8	24	16.5	24'	580	8'	167	14860
07340102	HLA 12-240160-3.0-24	3	10240	240	1	14.8	24	16.5	24'	580	8'	167	14860
07340202	HLA 12-240360-3.0-24	3	10240	240	3	8.6	24	16.5	24'	580	8'	167	14860
07340302	HLA 12-480360-3.0-24	3	10240	480	3	4.3	24	16.5	24'	580	8'	167	14860
07343602	HLA 12-208160-5.0-24	5	17100	208	1	26	24	27.6	24'	580	8'	167	15487
07340502	HLA 12-208360-5.0-24	5	17100	208	3	15.4	24	27.6	24'	580	8'	167	15487
07340602	HLA 12-240160-5.0-24	5	17100	240	1	23.1	24	27.6	24'	580	8'	167	15487
07340702	HLA 12-240360-5.0-24	5	17100	240	3	13.4	24	27.6	24'	580	8'	167	15487
07340802	HLA 12-480360-5.0-24	5	17100	480	3	6.7	24	27.6	24'	580	8'	167	15487
07343702	HLA 12-208160-7.5-24	7.5	25600	208	1	38	24	41.4	24'	580	8'	167	16101
07341002	HLA 12-208360-7.5-24	7.5	25600	208	3	22.3	24	41.4	24'	580	8'	167	16101
07341102	HLA 12-240160-7.5-24	7.5	25600	240	1	33.6	24	41.4	24'	580	8'	167	16101
07341202	HLA 12-240360-7.5-24	7.5	25600	240	3	19.4	24	41.4	24'	580	8'	167	16101
07341302	HLA 12-480360-7.5-24	7.5	25600	480	3	9.7	24	41.4	24'	580	8'	167	16101
07341502	HLA 16-208360-10.0-24	10	34150	208	3	29.3	24	21.7	40'	1500	10'	193	17031
07341602	HLA 16-240160-10.0-24	10	34150	240	1	44	24	21.7	40'	1500	10'	193	17031
07341702	HLA 16-240360-10.0-24	10	34150	240	3	25.5	24	21.7	40'	1500	10'	193	17031
07341802	HLA 16-480360-10.0-24	10	34150	480	3	12.7	24	21.7	40'	1500	10'	193	17031
07342002	HLA 20-208360-15.0-24	15	51200	208	3	43.5	24	19.2	43'	2450	13'	193	17769
07342102	HLA 20-240360-15.0-24	15	51200	240	3	38.1	24	19.2	43'	2450	13'	193	17769
07342202	HLA 20-480360-15.0-24	15	51200	480	3	19	24	19.2	43'	2450	13'	193	17769
07342302	HLA 20-600360-15.0-24	15	51200	600	3	15.2	24	19.2	43'	2450	13'	193	17769
07342402	HLA 20-480360-20.0-24	20	68300	480	3	25.1	24	26.2	43'	2450	13'	225	18456
07342502	HLA 20-600360-20.0-24	20	68300	600	3	20	24	26.2	43'	2450	13'	225	18456
07342602	HLA 20-480360-25.0-24	25	85400	480	3	31.1	24	32.8	43'	2450	13'	225	20093
07342702	HLA 20-600360-25.0-24	25	85400	600	3	24.9	24	32.8	43'	2450	13'	225	20093

Note: Products listed in this section are custom built and subject to 100% cancellation/restock charges.

Mounting Bracket Kits

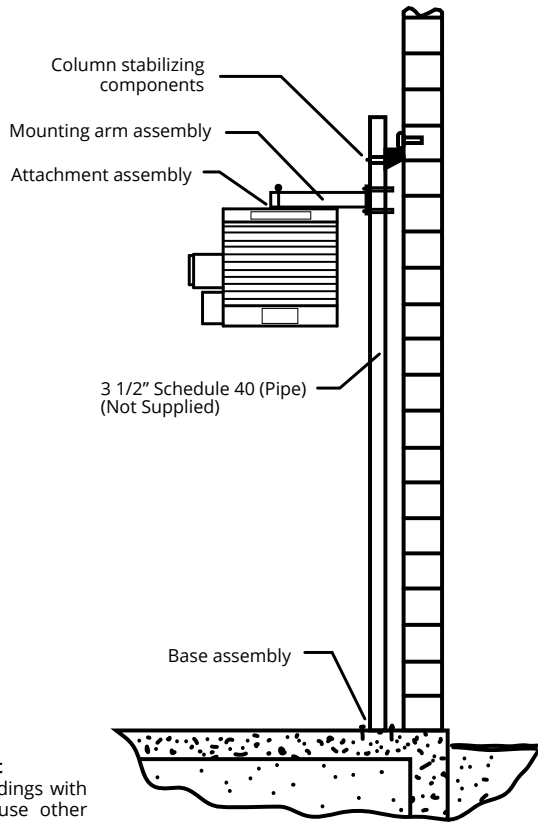

HPLM Pipe Mounting Kit
Particularly useful in buildings with insufficient strength to use other types of mounts. Requires 3 1/2" pipe (4" O.D. - not supplied).

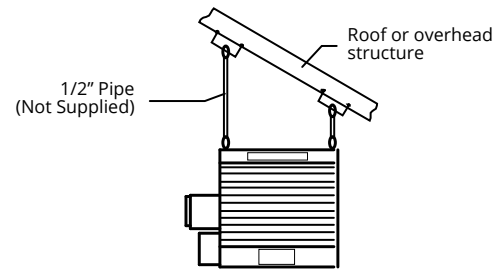

HLHM Hanging Mounting Kit
Simple and economical if adequate overhead structure exists. Requires 1/2" pipe, cut and threaded (not supplied)

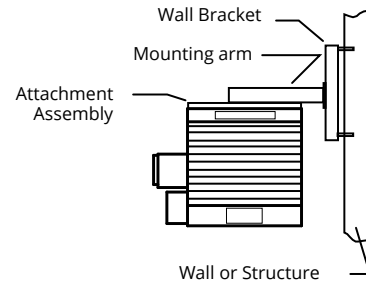

HLWM Wall Mounting Kit
Ideal for use in buildings that have substantial walls. Arm only can also be bolted directly to structural steel.

MFG CATALOG NUMBER	MFG MODEL NUMBER	USE WITH HEATERS	WT. (LBS)	LIST
07342802	HLP37	3.0 kW - 7.5 kW	37	809
07342902	HLP10	10.0 kW	38	809
07343002	HLP1525	15.0 kW - 25.0 kW	40	809
07343102	HLHM	ALL	5	341
07343202	HLWM37	3.0 kW - 7.5 kW	27	672
07343302	HLWM10	10.0 kW	28	672
07343402	HLWM1525	15.0 kW - 25.0 kW	29	672

EPET Series and HLT Series Hazardous Location Thermostats For Single Phase

Features

- Celsius and Fahrenheit temperature scale
- Bi-metal or capillary sensor
- Snap action switch
- Casting tapped top and bottom for 3/4" conduit
- 1/2" thick cast aluminum housing
- All EPET optional thermostats manufactured with anti-static plastic
- Dimension 5.75" x 6.375" x 5.57"
- Made in U.S.A.



EPET Series



HLT Series



MFG CATALOG NUMBER	MFG MODEL NUMBER	DESCRIPTION	LOAD RATINGS	RANGE	LIST
05381002	EPETD8S	SPDT - Bi-Metal	22A @120-277VAC	50-90°F	579
05231502	HLT-1	SPDT - Capillary	22A @120-277VAC	40-110°F	794
Master ctn: 4 pcs, 24 lbs (varies slightly by model), 16" x 14.5" x 6"					
EPET Series incorporate plastic knob & Bi-Metal Sensor housing.					
HLT Series incorporates screwdriver temperature adjustment slot and all metal housing. External bulb and capillary sensor.					

WARNING: This product can expose you to chemicals including nickel which is known to the State of California to cause cancer, and chromium, which is known to the State of California to cause birth defects and/or reproductive harm. For more information go to www.P65Warnings.ca.gov.

Motor Rating	Rating	Rated*
(full load) 1 1/2 HP at 250V	22A at 125-277VAC; 125 VA at 24VAC	Class I Group C & D, Class II Group E, F, G
*Thermostat is not rated for use in Group B environments.		

HLA Series Hazardous Location Fan Forced Unit Heater

Factory Installed Accessories & Physical Dimensions

SUFFIX	DESCRIPTION	LIST ADDER
120	Control transformer w/ primary fusing (Delete 24 suffix - add 120)	391
208	208/240V Control available on 208/240V units (Delete 24 suffix and add 208 OR 240)	90
240		90
D	Disconnect Switch	867
P	Pilot Light	394
T	In-Built single pole thermostat 40° - 100° F	544

MFG MODEL	A	B	C		D	E	F	G
			3 ph.	1 ph.				
HLA 12	17 ¾	22 ¾	19 ¾	20 ¾	16 ¼	10 ½	14	3
HLA 16	20 ¾	26 ¾	20 ¾	21 ¾	20 ¼	11 ½	18	4
HLA 20	24 ¾	30 ¾	22 ½	N/A	24 ¼	12 ½	22	4 ½

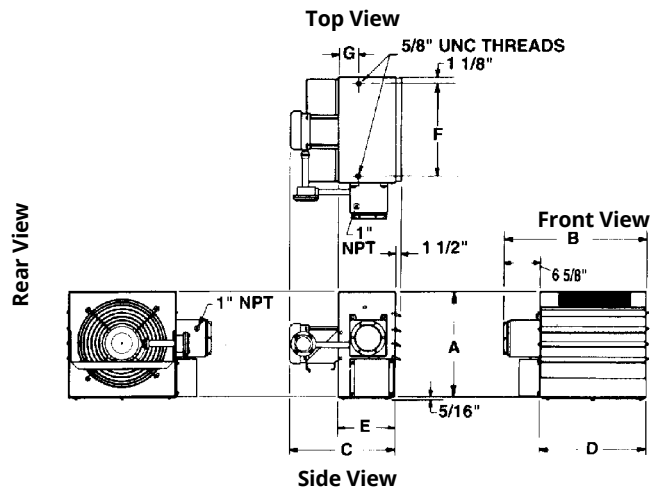

PHLA Series Portable Hazardous Location Fan Forced Unit Heater



- 3.0 through 25 KW rating
- 208, 240, 480, 600 Volt available in selected capacities
- Cart has anti-static wheels to reduce the risk of static discharge
- Wheeled cart allows for easy maneuverability
- Cart has integrated fork-lift channels to provide ease of lifting on to ramps or trucks
- Excellent for providing seasonal heating in hazardous environments
- All units have disconnect switch, pilot light, and thermostat - standard
- 24 Volt control, transformer, and contactor in NEMA 7 enclosure
- Durable epoxy coating on heater housing
- Hazardous location unit mounted male / female plug
- Adjustable louvers; manual reset
- Made in U.S.A.

Standard Portable Hazardous Location Models

MFG CATALOG NUMBER	MFG MODEL NUMBER	KW	BTUs	VOLTS	PH	AMPS	TEMP RISE F	AIR THROW	CFM	WT. (LBS)	LIST
07393402	PHLA12-208160-3.0-24-TDP	3	10,250	208	1	16.3	16.5	24'	580	260	31676
07393302	PHLA12-208360-3.0-24-TDP	3	10,250	208	3	9.8	17.5	24'	580	260	31676
07393202	PHLA12-240160-3.0-24-TDP	3	10,250	240	1	14.8	18.5	24'	580	260	31676
07393102	PHLA12-240360-3.0-24-TDP	3	10,250	240	3	8.6	19.5	24'	580	260	31676
07393002	PHLA12-480360-3.0-24-TDP	3	10,250	480	3	4.3	20.5	24'	580	260	31676
07394302	PHLA12-600360-3.0-24-TDP	3	10,250	600	3	3.5	21.5	24'	580	260	31676
07392902	PHLA12-208160-5.0-24-TDP	5	17,100	208	1	26	27.6	24'	580	260	32231
07392802	PHLA12-208360-5.0-24-TDP	5	17,100	208	3	15.4	28.6	24'	580	260	32231
07392702	PHLA12-240160-5.0-24-TDP	5	17,100	240	1	23.1	29.6	24'	580	260	32231
07392602	PHLA12-240360-5.0-24-TDP	5	17,100	240	3	13.4	30.6	24'	580	260	32231
07392502	PHLA12-480360-5.0-24-TDP	5	17,100	480	3	6.7	31.6	24'	580	260	32231
07394202	PHLA12-600360-5.0-24-TDP	5	17,100	600	3	5.4	32.6	24'	580	260	32231
07392402	PHLA12-208160-7.5-24-TDP	7.5	25,600	208	1	38	41.4	24'	580	260	32865
07392302	PHLA12-208360-7.5-24-TDP	7.5	25,600	208	3	22.3	42.4	24'	580	260	32865
07392202	PHLA12-240160-7.5-24-TDP	7.5	25,600	240	1	33.6	43.4	24'	580	260	32865
07392102	PHLA12-240360-7.5-24-TDP	7.5	25,600	240	3	19.4	44.4	24'	580	260	32865
07392002	PHLA12-480360-7.5-24-TDP	7.5	25,600	480	3	9.7	45.4	24'	580	260	32865
07394102	PHLA12-600360-7.5-24-TDP	7.5	25,600	600	3	7.8	46.4	24'	580	260	32865
07391902	PHLA16-208360-10.0-24-TDP	10	34,150	208	3	29.3	21.7	40'	1500	305	35565
07391802	PHLA16-240160-10.0-24-TDP	10	34,150	240	1	44	22.7	40'	1500	305	35565
07391702	PHLA16-240360-10.0-24-TDP	10	34,150	240	3	25.5	23.7	40'	1500	305	35565
07391602	PHLA16-480360-10.0-24-TDP	10	34,150	480	3	12.7	24.7	40'	1500	305	35565
07394002	PHLA16-600360-10.0-24-TDP	10	34,150	600	3	10.2	25.7	40'	1500	305	35565
07391502	PHLA20-208360-15.0-24-TDP	15	51,200	208	3	43.5	19.2	43'	2450	350	38329
07391402	PHLA20-240360-15.0-24-TDP	15	51,200	240	3	38.1	20.2	43'	2450	350	38329
07391302	PHLA20-480360-15.0-24-TDP	15	51,200	480	3	19	21.2	43'	2450	350	38329
07393902	PHLA20-600360-15.0-24-TDP	15	51,200	600	3	15.2	22.2	43'	2450	350	38329
07391202	PHLA20-480360-20.0-24-TDP	20	68,300	480	3	25.1	26.2	43'	2450	350	39058
07393802	PHLA20-600360-20.0-24-TDP	20	68,300	600	3	20	27.2	43'	2450	350	39058
07391102	PHLA20-480360-25.0-24-TDP	25	85,400	480	3	31.1	32.8	43'	2450	350	40328
07393702	PHLA20-600360-25.0-24-TDP	25	85,400	600	3	24.9	32.8	43'	2450	350	40328

Note: Products listed in this section are custom built and subject to 100% cancellation/restock charges.

FEP Series Single Phase Hazardous Location Wall Convectors



Standard Unit



Unit with in-built EPET line voltage thermostat (Suffix T1 or T2)

T-2A SERIES SINGLE PHASE Class 1, Group B, C & D Division 1 & 2 280° C / 536° F								
MFG CATALOG NUMBER	MFG MODEL NUMBER	WATTS	BTUs	VOLTS	AMPS	CABINET LENGTH	WT. (LBS.)	LIST
04451402	FEP-1812-1RA	1800	6143	120	15	34"	50	2466
04451502	FEP-1820-1RA	1800	6143	208	8.7	34"	50	2466
04451602	FEP-1824-1RA	1800	6143	240	7.5	34"	50	2466
04451702	FEP-1827-1RA	1800	6143	277	6.5	34"	50	2466
04451802	FEP-1848-1RA	1800	6143	480	3.8	34"	50	2466
04451902	FEP-3620-1RA	3600	12286	208	17.3	34"	54	3765
04452002	FEP-3624-1RA	3600	12286	240	15	34"	54	3765
04452102	FEP-3627-1RA	3600	12286	277	13	34"	54	3765
04452202	FEP-3648-1RA	3600	12286	480	7.5	34"	54	3765
04452302	FEP-3657-1RA	3600	12286	600	6	34"	54	3765
04452402	FEP-3820-1RA	3800	12969	208	18.3	58"	80	3992
04452502	FEP-3824-1RA	3800	12969	240	15.8	58"	80	3992
04452602	FEP-3827-1RA	3800	12969	277	13.7	58"	80	3992
04452702	FEP-3848-1RA	3800	12969	480	7.9	58"	80	3992
04452802*	FEP-7620-1RA	7600	25938	208	36.5*	58"	85	4644
04452902*	FEP-7624-1RA	7600	25938	240	31.7*	58"	85	4644
04453002*	FEP-7627-1RA	7600	25938	277	27.4*	58"	85	4644
04453102	FEP-7648-1RA	7600	25938	480	15.8	58"	85	4644
04453202	FEP-7657-1RA	7600	25938	600	12.7	58"	85	4644

- Cabinet size 18" high, 9" wide
- Wall mounting bracket supplied
- Units can not be operated in room ambients exceeding 104°F (40°C)
- Heavy duty 16 gauge steel with gray epoxy textured powder coated finish
- 9" minimum clearance from bottom of heater to floor required
- Stainless steel cartridge element inserted into Aluminum finned Copper sheath
- Standard unit (without EPET thermostat or control section) is NEMA 4 rated
- Made in U.S.A.

WARNING: This product can expose you to chemicals including nickel which is known to the State of California to cause cancer, and chromium, which is known to the State of California to cause birth defects and/or reproductive harm. For more information go to www.P65Warnings.ca.gov.

T-3A SERIES SINGLE PHASE Class 1, Group B, C & D Division 1 & 2 180° C / 356° F								
MFG CATALOG NUMBER	MFG MODEL NUMBER	WATTS	BTUs	VOLTS	AMPS	CABINET LENGTH	WT. (LBS.)	LIST
04453302	FEP-0812-1RA	800	2730	120	6.7	34"	50	2466
04453402	FEP-0820-1RA	800	2730	208	3.8	34"	50	2466
04453502	FEP-0824-1RA	800	2730	240	3.3	34"	50	2466
04453602	FEP-0827-1RA	800	2730	277	2.9	34"	50	2466
04453702	FEP-0848-1RA	800	2730	480	1.7	34"	50	2466
04453802	FEP-1612-1RA	1600	5460	120	13.3	34"	54	3765
04453902	FEP-1620-1RA	1600	5460	208	7.7	34"	54	3765
04454002	FEP-1624-1RA	1600	5460	240	6.7	34"	54	3765
04454102	FEP-1627-1RA	1600	5460	277	5.8	34"	54	3765
04454202	FEP-1648-1RA	1600	5460	480	3.3	34"	54	3765
04454302	FEP-1657-1RA	1600	5460	600	2.7	34"	54	3765
04454402	FEP-1712-1RA	1700	5802	120	14.2	58"	80	3992
04454502	FEP-1720-1RA	1700	5802	208	8.2	58"	80	3992
04454602	FEP-1724-1RA	1700	5802	240	7.1	58"	80	3992
04454702	FEP-1727-1RA	1700	5802	277	6.1	58"	80	3992
04454802	FEP-1748-1RA	1700	5802	480	3.5	58"	80	3992
04454902	FEP-3420-1RA	3400	11604	208	16.3	58"	85	4644
04455002	FEP-3424-1RA	3400	11604	240	14.2	58"	85	4644
04455102	FEP-3427-1RA	3400	11604	277	12.3	58"	85	4644
04455202	FEP-3448-1RA	3400	11604	480	7.1	58"	85	4644
04455302	FEP-3457-1RA	3400	11604	600	5.7	58"	85	4644

Factory Installed Control Options

SUFFIX*	DESCRIPTION	LIST
T1	EPETP8S single pole thermostat factory mounted to 120V - 480V units. (50°F - 90°F)	984
T2	EPETP8D double pole thermostat factory mounted to 120V - 480V units. (50°F - 90°F)	1020

*Remove - RA suffix and add new suffix. Suffix "T" is 22 Amps maximum.

Note: All EPET / T1 / T2 optional thermostats manufactured with anti-static plastic

Note: Products listed in this section are custom built and subject to 100% cancellation/restock charges.

FEP Series Three Phase Hazardous Location Wall Convectector

- Cabinet size 18" high, 9" wide
- Bottom In - Top Out air flow
- Wall mounting bracket supplied
- Units can not be operated in room ambients exceeding 104°F (40°C)
- Heavy duty 16 gauge steel with gray epoxy textured powder coated finish
- 9" minimum clearance from bottom of heater to floor required
- Stainless steel cartridge element inserted into Aluminum finned Copper sheath
- Standard unit (without EPET thermostat or control section) is NEMA 4 rated
- Made in U.S.A.



T-2A SERIES THREE PHASE Class 1, Group B, C, & D Divisions 1 & 2 280° C / 536° F								
MFG CATALOG NUMBER	MFG MODEL NUMBER	WATTS	BTUs	VOLTS	AMPS	CABINET LENGTH	WT. (LBS.)	LIST
04830502	FEP-1820-3RA	1800	6143	208	5.0	34"	50	2842
04830602	FEP-1824-3RA	1800	6143	240	4.3	34"	50	2842
04862202	FEP-1848-3RA	1800	6143	480	2.2	34"	50	2940
04830702	FEP-3620-3RA	3600	12286	208	10.0	34"	54	4332
04830802	FEP-3624-3RA	3600	12286	240	8.7	34"	54	4332
04862302	FEP-3648-3RA	3600	12286	480	4.3	34"	54	4290
04830902	FEP-3820-3RA	3800	12969	208	10.5	58"	80	4599
04831002	FEP-3824-3RA	3800	12969	240	9.1	58"	80	4599
04862402	FEP-3848-3RA	3800	12969	480	4.6	58"	80	4953
04831102	FEP-7620-3RA	7600	25938	208	21.1	58"	85	5325
04831202	FEP-7624-3RA	7600	25938	240	18.3	58"	85	5325
04862502	FEP-7648-3RA	7600	25938	480	9.2	58"	85	5325

T-3A SERIES THREE PHASE Class 1, Group B, C & D Division 1 & 2 180° C / 356° F								
MFG CATALOG NUMBER	MFG MODEL NUMBER	WATTS	BTUs	VOLTS	AMPS	CABINET LENGTH	WT. (LBS.)	LIST
04831302	FEP-0820-3RA	800	2730	208	2.2	34"	50	2842
04831402	FEP-0824-3RA	800	2730	240	1.9	34"	50	2842
04862602	FEP-0848-3RA	800	2730	480	0.9	34"	50	3087
04831502	FEP-1620-3RA	1600	5460	208	4.4	34"	54	4332
04831602	FEP-1624-3RA	1600	5460	240	3.8	34"	54	4332
04862702	FEP-1648-3RA	1600	5460	480	1.9	34"	54	4505
04831702	FEP-1720-3RA	1700	5802	208	4.7	58"	80	4599
04831802	FEP-1724-3RA	1700	5802	240	4.1	58"	80	4599
04862802	FEP-1748-3RA	1700	5802	480	2.0	58"	80	4953
04831902	FEP-3420-3RA	3400	11604	208	9.4	58"	85	5273
04832002	FEP-3424-3RA	3400	11604	240	8.2	58"	85	5273
04862902	FEP-3448-3RA	3400	11604	480	4.1	58"	85	5273

Note: C1-TD and C1-TDP are only options available for 3 phase units.
T1 and T2 option not available on 3 phase models



WARNING: This product can expose you to chemicals including nickel which is known to the State of California to cause cancer, and chromium, which is known to the State of California to cause birth defects and/or reproductive harm. For more information go to www.P65Warnings.ca.gov.

Note: Controls mounted on the left side only

Factory Installed Control Options

SUFFIX**	DESCRIPTION	LIST
C1-TD	Control section with transformer, 24V contactor, SP thermostat (40°F - 100°F) and disconnect switch (all units)	3192
C1-TDP	Control section with transformer, 24V contactor, SP thermostat (40°F - 100°F), disconnect switch & pilot light (all units)	3316

**Remove - RA suffix and add new suffix (Not NEMA washdown rated or rated for Group B atmospheres)

Remote Mounted Hazardous Location Thermostats For Single Phase Power Only



HLT Series



WARNING: This product can expose you to chemicals including nickel which is known to the State of California to cause cancer, and chromium, which is known to the State of California to cause birth defects and/or reproductive harm. For more information go to www.P65Warnings.ca.gov.



EPET Series Parameters

Note: Products listed in this section are custom built and subject to 100% cancellation/restock charges.

MFG CATALOG NUMBER	MFG MODEL NUMBER	DESCRIPTION	LOAD RATINGS	RANGE	LIST
05380702	EPETD8D	DPDT - Bi-Metal	22A @120-277VAC	50-90°F	579
05381002	EPETD8S	SPDT - Bi-Metal	22A @120-277VAC	50-90°F	579
05280702	EPETP8D	DPDT - Bi-Metal	22A @120-480VAC	50-90°F	579
05280602	EPETP8S	SPDT - Bi-Metal	22A @120-480VAC	50-90°F	579
05231502	HLT-1	SPDT - Capillary	22A @120-277VAC	40-110°F	794
05231602	HLT-2	DPDT - Capillary	22A @120-277VAC	40-110°F	838
Master ctn: 4 pcs, 24 lbs (varies slightly by model), 16" x 14.5" x 6"					
EPET Series incorporates plastic knob & Bi-Metal Sensor housing.					
HLT Series incorporates screwdriver temperature adjustment slot and all metal housing. External bulb and capillary sensor.					

Note: All EPET / T1 / T2 optional thermostats manufactured with anti-static plastic

Motor Rating	Rating	Rated*
(full load) 1 1/2 HP @ 250V	22A @ 125-277VAC; 125 VA @ 24VAC	Class I Group C & D, Class II Group E, F, G
Thermostat is not rated for use in Group B environments.		
Dimensions	Finish	Type
H: 5 5/8", W: 6 3/8" D: 4 1/2"	Silver-Gray	Single or Double Pole

5500 Series Washdown Fan Forced Unit Heater

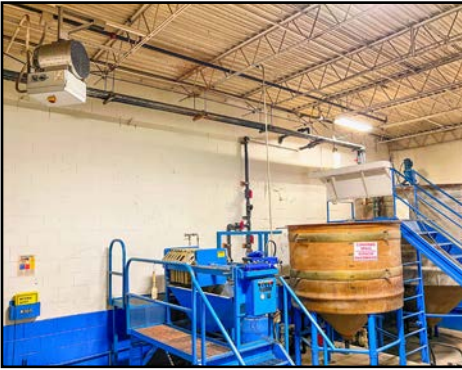

The Washdown Series unit heaters are electric unit heaters constructed for use in areas that require washing or hosing of equipment due to dirty or dusty industrial environments in non-hazardous locations. The totally enclosed water-tight construction made with corrosion-resistant material make this series ideal for industrial heating applications. The Washdown Series is constructed with all built-in controls and safety temperature controls wired in a non-metallic Nema 4x control panel with single-point power connections.

- Heavy-duty 304 16 gauge stainless steel shroud
- 316 stainless construction available
- Nema 4x non-metallic control panel
- 24-Volt control
- 3-position switch (off-heat-fan)
- Capillary thermostat with stainless steel sensor
- Automatic reset thermal cutout
- Totally enclosed U.L. listed motor
- Pilot light (power on indicator)
- Stainless steel finned tubular element. Constructed of 304 or 316 stainless rod and fins
- Control panel on bottom of unit for ease of installation and service
- Disconnect switch with enclosure door interlock
- Front grill rotates to direct airflow
- Single-point power connection
- Fan Blade Aluminum
- Epoxy painted cold roll steel model available, consult factory
- Meets all U.L., NEC, and OSHA requirements (when installed as directed)
- Corrosion-resistant in high humidity and water-saturated areas (for areas where corrosion resistance is needed in non-explosive areas, contact factory for heater applications and optional materials)
- Thermostat temp range: 40°-110°F
- Made in U.S.A.

Mounting Bracket Kits & Product Dimensions

SIZE KW	MFG CATALOG NUMBER	STAINLESS STEEL COMBINATION BRACKET	LIST	MFG CATALOG NUMBER	WALL MTG. BRACKET *	LIST	MFG CATALOG NUMBER	HANGING BRACKET *	LIST	MFG CATALOG NUMBER	PIPE MTG. BRACKET *	LIST
3.3-15	07136702	A5520/UHB	501	07137202	W5520/WMK	711	07137002	H5520/HMK	501	07136802	P5520/PMK	711
20-48		----	-	07137302	W5550/WMK	711	07137102	H5550/HMK	501	07136902	P5550/PMK	711

<p>A5520</p> <p>3-15 Kw ONLY</p>	<p>W5550 Ideal for use in buildings that have substantial walls. Arm (only) can be bolted directly to structural steel.</p> <p>Labels: WALL BRACKET, MOUNTING ARM, WALL OR STRUCTURE</p>	<p>H5550 Simple and economical if adequate overhead structure exists. Requires 1/2" pipe, cut & threaded (not supplied).</p> <p>Labels: ROOF OR OVERHEAD STRUCTURE, 1/2" PIPE (NOT SUPPLIED)</p>	<p>P5550 Particularly useful in buildings with insufficient strength to use other types of mounts. Requires 3 1/2" pipe (4" O.D.-not supplied).</p> <p>Labels: COLUMN STABILIZING COMPONENTS, MOUNTING ARM ASSY., BASE ASSEMBLY</p> <p>3 1/2" SCHEDULE 40 PIPE (NOT SUPPLIED)</p>
--	---	---	--

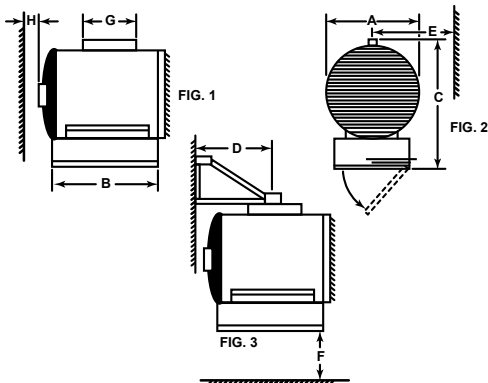

Heater KW	Heater Dimension in Inches unless otherwise stated.							
	A	B	C	D	E	F	G	H
3-7.5	12.00	18.00	19.75	15.25	16.25	6 ft.	8.00	6.00
10-15	14.00	19.00	21.75	15.25	18.00		8.00	6.00
20-30	16.00	27.00	28.75	19.50	17.50		15.50	4.50
40-48	18.00	31.00	30.75	19.50	19.50		21.75	2.75

5500 Series Washdown Fan Forced Unit Heater

Product Specifications & Standard Washdown Models

Enclosure and Motor:

Element housing shall be 16 gauge 304 or 316 stainless steel shroud. The outlet grill and louver assembly shall be 304/316 stainless steel and rotate for direction of discharge air. The heater shall have a 304/316 stainless steel inlet grill and fan guard. The motor shall be totally enclosed, permanently lubricated and designed to resist moisture and corrosion. The fan blade shall be aluminum.

Element:

The heating element shall be 304 or 316 stainless steel tube with 304/316 stainless steel fin material helically attached to the tube for even heat transfer. The element designed with the highest quality nickel-chromium resistance wire embedded in compacted efficient dielectric to ensure proper heat transfer.

Control Panel:

The control enclosure shall be non-metallic Nema 4X control panel water-tight and dust-tight. The enclosure and elements are attached to the control panel with stainless steel fasteners. Standard control components are factory mounted and wired with access through control panel door on bottom of heater assembly. A standard door interlock disconnect switch shall be factory mounted and wired for safety.

Controls:

All controls shall be factory mounted and wired in Nema 4X panel. Terminal block, 24 Volt transformer, high temperature limits, contactor and fusing if required by NEC are mounted and wired in control panel. A three-position switch (Off-Heat-Fan) shall be mounted on side of control panel for access from outside of panel. A pilot light to indicate power is on for safety shall be located on side of control panel. A wall mounted Nema 4X thermostat is an optional accessory.

Mounting Bracket:

A formed 304/316 stainless steel bracket shall be used on 3.3 thru 15 KW units. A cast iron epoxy painted bracket shall be used on 20 thru 48 KW units. Above brackets shall be combination wall/ceiling type. Optional mounting brackets are available.

MFG CATALOG NUMBER	MFG MODEL NUMBER	KW	BTUs	VOLTS	PH	AMPS	CONTROL VOLTAGE	TEMP RISE °F	AIR THROW	CFM	WT. (LBS)	LIST
07131302	F1F5503T	3.3	11200	208	1	15.9	24	26	20'	400	58	6466
07130402	F3F5503T	3.3	11200	208	3	9.2	24	26	20'	400	58	6466
07130502	H1H5503T	3.3	11200	240	1	13.7	24	26	20'	400	58	6466
07130602	H3H5503T	3.3	11200	240	3	7.9	24	26	20'	400	58	6466
07130702	G1G5503T	3.3	11200	277	1	11.9	24	26	20'	400	58	6466
07130802	P3P5503T	3.3	11200	480	3	4	24	26	20'	400	58	6466
07130902	F1F5505T	5	17100	208	1	24.1	24	40	20'	400	58	6712
07131102	F3F5505T	5	17100	208	3	13.9	24	40	20'	400	58	6712
07131202	H1H5505T	5	17100	240	1	20.8	24	40	20'	400	58	6712
07131402	H3H5505T	5	17100	240	3	12.1	24	40	20'	400	58	6712
07131502	G1G5505T	5	17100	277	1	18.1	24	40	20'	400	58	6712
07131602	P3P5505T	5	17100	480	3	6.1	24	40	20'	400	58	6712
07131802	F1F5507T	7.5	25600	208	1	36.1	24	60	20'	400	58	7646
07131902	F3F5507T	7.5	25600	208	3	20.8	24	60	20'	400	58	7646
07132002	H1H5507T	7.5	25600	240	1	31.3	24	60	20'	400	58	7646
07132102	H3H5507T	7.5	25600	240	3	13.1	24	60	20'	400	58	7646
07132202	G1G5507T	7.5	25600	277	1	27.1	24	60	20'	400	58	7646
07132302	P3P5507T	7.5	25600	480	3	9.1	24	60	20'	400	58	7646
07132502	F1F5510T	10	34130	208	1	47.8	24	45	28'	700	64	9197
07132602	F3F5510T	10	34130	208	3	27.7	24	45	28'	700	64	9197
07132702	H1H5510T	10	34130	240	1	41.2	24	45	28'	700	64	9197
07132802	H3H5510T	10	34130	240	3	24.1	24	45	28'	700	64	9197
07132902	G1G5510T	10	34130	277	1	36.1	24	45	28'	700	64	9197
07133002	P3P5510T	10	34130	480	3	12.1	24	45	28'	700	64	9197
07133902	F1F5515T	15	51200	208	1	72.1	24	68	28'	700	64	10549
07134002	F3F5515T	15	51200	208	3	41.7	24	68	28'	700	64	10549
07134102	H1H5515T	15	51200	240	1	62.5	24	68	28'	700	64	10549
07134202	H3H5515T	15	51200	240	3	36.1	24	68	28'	700	64	10549
07134402	P3P5515T	15	51200	480	3	18.1	24	68	28'	700	64	10549
07134602	F3F5520T	20	68260	208	3	55.6	24	45	35'	1400	92	12115
07134702	H3H5520T	20	68260	240	3	48.2	24	45	35'	1400	92	12115
07134802	P3P5520T	20	68260	480	3	24.1	24	45	35'	1400	92	12115
07135002	F3F5525T	25	85325	208	3	69.5	24	56	35'	1400	92	12115
07135102	H3H5525T	25	85325	240	3	60.2	24	56	35'	1400	92	12115
07135202	P3P5525T	25	85325	480	3	30.1	24	56	35'	1400	92	12115
07135402	F3F5530T	30	102390	208	3	83.4	24	68	35'	1400	92	13225
07135502	H3H5530T	30	102390	240	3	72.3	24	68	35'	1400	92	13225
07135602	P3P5530T	30	102390	480	3	36.1	24	68	35'	1400	92	13225
07136002	P3P5540T	40	136520	480	3	48.2	24	70	42'	1800	126	13789
07136402	P3P5548T	48	163824	480	3	57.8	24	84	42'	1800	126	17148

Note: Products listed in this section are custom built and subject to 100% cancellation/restock charges.

Note: For 60Amp disconnect add \$53.00 Net. Add 'D' as the suffix; For optional monel elements, add 40% to the net of the heater. For powder coat epoxy painting of shroud, add \$221 list to heater pricing. For 316 stainless add 20% to net price of the heater.

Remote Rain-Tight Thermostat



MFG CATALOG NUMBER	MFG MODEL NUMBER	DESCRIPTION	LIST
05234202	TW155A	1 POLE, 40-110°F, 22Amp	297
05234302	TW255A	2 POLE, 40-110 °F, 22Amp	344

WARNING: This product can expose you to chemicals including nickel which is known to the State of California to cause cancer, and chromium, which is known to the State of California to cause birth defects and/or reproductive harm. For more information go to www.P65Warnings.ca.gov.

- NEMA 4X Construction with Stainless Steel Hardware
- Made in U.S.A. with domestic and foreign components

UH Series Horizontal Fan Forced Unit Heater

3.3 kW through 48 kW horizontal discharge suspended fan forced unit heaters available in 1 or 3 Phase for all standard voltages from 208V to 480V.



FACTORY INSTALLED OPTIONS:

- 24 Volt transformer on 3 KW to 15KW units to convert from line voltage to low voltage remote thermostat operation.
- Summer fan switch to operate the fan only.
- Fan delay switch to purge all residual heat from the unit after the heating element has cycled off.
- Powder coated epoxy finish for corrosive atmospheres.
- Disconnect switch.
- Made in U.S.A.

MAXIMUM RECOMMENDED MOUNTING HEIGHT	
3 - 10 KW	9 FT.
12 - 15 KW	10 FT.
20 - 30 KW	13 FT.
40 - 48 KW	16 FT.



WARNING: This product can expose you to chemicals including nickel which is known to the State of California to cause cancer, and chromium, which is known to the State of California to cause birth defects and/or reproductive harm. For more information go to www.P65Warnings.ca.gov.

CONSTRUCTION:

Heavy gauge welded steel cabinet with powder coated finish and control compartment with a hinged and latched access door, simplifying wiring installation and maintenance

HEATING ELEMENT:

Circular copper clad steel sheath element with continuously brazed steel fins formed to match the air delivery pattern of the fan blade

OVERHEAT PROTECTION:

All units come equipped with automatic resetting type limit controls to de-energize the heater should an over-temperature situation occur

FAN and MOTOR:

Totally enclosed, single phase, permanently lubricated, thermally protected motors with unit bearings on 3 KW - 10 KW models and sleeve bearings on 12.5 KW - 48 KW models - mounted with rubber insulators to minimize vibration and noise. Fan assembly enclosed by a heavy gauge, close spaced, chrome plated wire guard

LOUVER ASSEMBLY:

Louvers are individually adjustable for directional control of air flow and the entire assembly can be repositioned in the field from down flow to up flow or left / right directional air flow

TEMPERATURE CONTROLS:

20 KW through 48 KW units and all 480V have built in 24 Volt transformer for low voltage remote thermostat application. 25 KW through 48 KW models available in 2-stage on special order (consult factory)

INSTALLATION:

Unit Heaters can be mounted with the motor shaft from horizontal to downward at 45° off horizontal. Pre-drilled holes and installed threaded nuts provided to allow hanging by threaded rods - 1/4" for units up to 15 KW and 5/16" for 20 KW units and larger. Optional wall / ceiling mounting brackets are available for all units

NOTE: Louver assembly is square and mounted with screws. Louver can be removed and repositioned for four (4) directional air flow - left - right - up - down with the heater in the horizontal position.

Product Dimensions & Model Number Designation

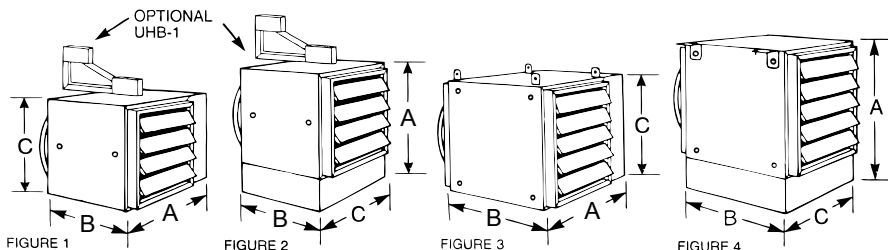

3.3 KW THROUGH 15 KW UNIT HEATERS

20 KW THROUGH 48 KW UNIT HEATERS

Dimensions	A	B	C
Figure 1: 3.3, 5, 7.5, 10 KW	20"	11"	13"
Figure 2: 12.5, 15 KW	22"	11"	15"
Figure 3: 20, 25, 30 KW	24"	17"	17"
Figure 4: 40, 48 KW	26"	23"	19"

Figures 3 & 4 shown with standard mounting tabs for units over 20 KW. Optional UHB-3 and UHB-4 wall brackets are available. 3.3 KW thru 15 KW units can be mounted using 1/4" threaded rod. 20 KW thru 48 KW units can be mounted using 5/16" threaded rod.

Factory & Field Installed Accessories

FACTORY INSTALLED OPTIONS		
SUFFIX	DESCRIPTION	LIST
F	Heat purge fan delay switch on 480v units CA1 low voltage transformer and contactor included	203
S	Summer Fan Switch	100
E	Epoxy Coating	192
T	SPST Thermostat (40°F - 110°F)	118
CA1	24v Transformer (3.3 KW - 15 KW units) & Contactor	256
CA2	120v Transformer (3.3 KW - 15 KW units) & Contactor	256
CA1F	Heat purge fan delay switch includes 24v transformer and contactor on 208-240-277 volt units	94
CA2F	Heat purge fan delay switch includes 120v transformer and contactor on 208--240-277 volt units	94
D	Disconnect Switch - 30 Amps; 0-24 Amps	485
D	Disconnect Switch - 40 Amps; 24.1-32 Amps	557
D	Disconnect Switch - 80 Amps; 32.1-64 Amps	697
D	Disconnect Switch - 100 Amps; 64.1-80 Amps	854

FIELD INSTALLED ACCESSORIES			
MFG CATALOG NUMBER	MFG MODEL NUMBER	DESCRIPTION	LIST
06462302	DCS303	30 Amp Disconnect Kit: 0-24 Amps	298
06462402	DCS403	40 Amp Disconnect Kit: 24.1-32 Amps	410
06462502	DCS803	80 Amp Disconnect Kit: 32.1-64 Amps	470
06462602	DCS1003	100 Amp Disconnect Kit: 64.1-80 Amps	431
06879902	TUH1	25 Amp SPST Thermostat (40°F - 110°F)	128
06991002	UHB-1	Wall / Ceiling Bracket 3.3 KW - 15 KW units	171
06991102	UHB-3	Wall / Ceiling Bracket 20 KW - 30 KW units	194
06991202	UHB-4	Wall / Ceiling Bracket 35 KW - 48 KW units	247

UH Series Horizontal Fan Forced Unit Heater

HOW TO DESIGNATE A MODEL:

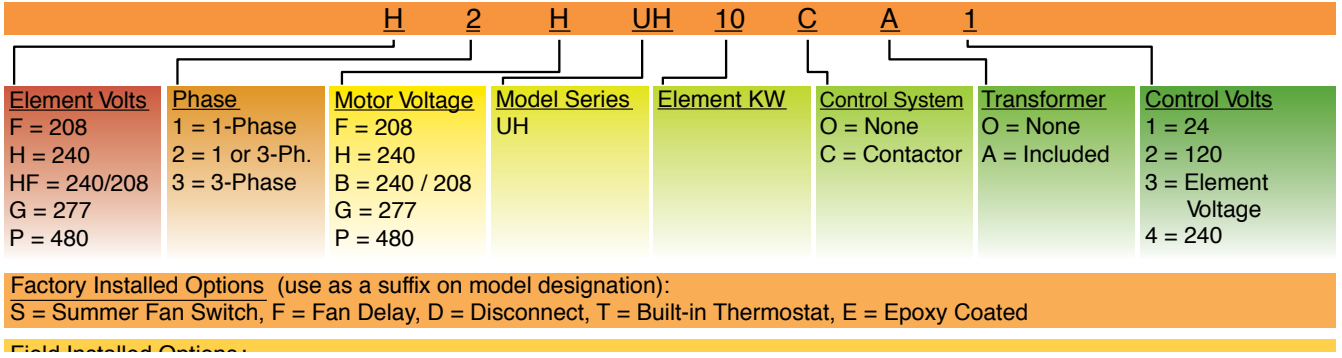

Standard Product Models

MFG CATALOG NUMBER	MFG MODEL NUMBER	KW	BTUs	VOLTS	PH	AMPS	CONTROL VOLTS	TEMP RISE °F	AIR THROW	CFM	RECOM'D MOUNTING HT.	WT. (LBS)	LIST
06446002	F1FUH03003	3.3	11200	208	1	15.9	208	26	26'	400	9'	36	1157
06446602	H1HUH03003	3.3	11200	240	1	13.8	240	26	26'	400	9'	36	1157
06447202	G1GUH03003	3.3	11200	277	1	11.9	277	26	26'	400	9'	36	1157
07114802	H3HUH03C03	3.3	11200	240	3	7.9	240	26	26'	400	9'	36	1157
07114902	F3FUH03C03	3.3	11200	208	3	9.2	208	26	26'	400	9'	36	1157
07114002	P3PUH03CA1	3.3	11200	480	3	4	24	26	26'	400	9'	36	1475
06446102	F1FUH05003	5	17100	208	1	24.1	208	40	26'	400	9'	36	1209
06446702	H1HUH05003	5	17100	240	1	20.8	240	40	26'	400	9'	36	1209
06447302	G1GUH05003	5	17100	277	1	18.1	277	40	26'	400	9'	36	1209
06449302	F2FUH05C03	5	17100	208	1 or 3	24.1 / 14.0	208	40	26'	400	9'	44	1209
06449402	H2HUH05C03	5	17100	240	1 or 3	20.8 / 12.1	240	40	26'	400	9'	44	1209
06448802	P3PUH05CA1	5	17100	480	3	6.1	24	40	26'	400	9'	44	1601
07180502	F1FUH07CA1	7.5	25600	208	1	36.1	24	42	36'	575	9'	40	1863
07173702	H1HUH07CA1	7.5	25600	240	1	31.3	24	42	36'	575	9'	41	1863
07151802	G1GUH07CA1	7.5	25600	277	1	27.1	24	42	36'	575	9'	41	1863
06447902	F3FUH07C03	7.5	25600	208	3	20.8	208	42	36'	575	9'	44	1863
06449502	H2HUH07C03	7.5	25600	240	1 or 3	31.3 / 18.1	240	42	36'	575	9'	44	1863
06448902	P3PUH07CA1	7.5	25600	480	3	9.1	24	42	36'	575	9'	44	2009
07170902	F1FUH10CA1	10	34100	208	1	48.1	24	55	36'	575	9'	42	2053
06808402	H1HUH10CA1	10	34100	240	1	41.7	24	55	36'	575	9'	42	2053
07173802	G1GUH10CA1	10	34100	277	1	36.1	24	55	36'	575	9'	42	2053
06449602	F2FUH10C03	10	34100	208	1 or 3	48.1 / 27.8	208	55	36'	575	9'	42	2053
06449702	HF2BUH10C03	10 / 7.5	34100	240	1 or 3	41.7 / 24.1	240	55	36'	575	9'	45	2053
06449702	HF2BUH10C03	10 / 7.5	25600	208	1 or 3	36.1 / 20.8	208	42	36'	575	9'	45	2053
07114202	P3PUH10CA1	10	34100	480	3	12.1	24	55	36'	575	9'	51	2129
06446402	F1FUH12C03	12.5	42600	208	1	60.1	208	49	45'	800	10'	45	3303
06447002	H1HUH12C03	12.5	42600	240	1	52.1	240	49	45'	800	10'	45	3303
06448102	F3FUH12C03	12.5	42600	208	3	34.7	208	49	45'	800	10'	45	3303
06448602	H3HUH12C03	12.5	42600	240	3	30.1	240	49	45'	800	10'	45	3303
07114302	P3PUH12CA1	12.5	42600	480	3	15.1	24	49	45'	800	10'	45	3435
06446502	F1FUH15C03	15	51200	208	1	72.1	208	59	45'	800	10'	54	3636
06447102	H1HUH15C03	15	51200	240	1	62.5	240	59	45'	800	10'	54	3636
06448202	F3FUH15C03	15	51200	208	3	41.7	208	59	45'	800	10'	54	3636
06448702	H3HUH15C03	15	51200	240	3	36.1	240	59	45'	800	10'	54	3636
07114402	P3PUH15CA1	15	51200	480	3	18.1	24	59	45'	800	10'	54	3778
06883002	F1FUH20CA1*	20	68300	208	1	96.2	24	47	56'	1350	13'	55	4987
06884202	H1HUH20CA1*	20	68300	240	1	83.3	24	47	56'	1350	13'	55	4987
06883102	F3FUH20CA1	20	68300	208	3	55.6	24	47	56'	1350	13'	55	4987
06884302	H3HUH20CA1	20	68300	240	3	48.2	24	47	56'	1350	13'	55	4987
06883202	P3PUH20CA1	20	68300	480	3	24.1	24	47	56'	1350	13'	55	4987
06884402	F1FUH25CA1*	25	85300	208	1	120.2	24	58	56'	1350	13'	55	5877
06883302	H1HUH25CA1*	25	85300	240	1	104.2	24	58	56'	1350	13'	55	5877
06884502	F3FUH25CA1	25	85300	208	3	69.5	24	58	56'	1350	13'	55	5877
06883402	H3HUH25CA1	25	85300	240	3	60.2	24	58	56'	1350	13'	55	5877
06884602	P3PUH25CA1	25	85300	480	3	30.1	24	58	56'	1350	13'	55	5877
06884702	H1HUH30CA1	30	102390	240	1	125	24	70	56'	1350	13'	60	6806
06883602	F3FUH30CA1*	30	102390	208	3	83.4	24	70	56'	1350	13'	60	6806
06884802	H3HUH30CA1	30	102390	240	3	72.3	24	70	56'	1350	13'	60	6806
06883702	P3PUH30CA1	30	102390	480	3	36.1	24	70	56'	1350	13'	60	6806
06884002	P3PUH40CA1	40	136500	480	3	48.2	24	55	56'	2275	16'	75	8696
06887802	P3PUH48CA1	48	163800	480	3	57.8	24	67	56'	2275	16'	78	10857

*Disconnect not available

UHE Series Horizontal Fan Forced Unit Heater

UHE Series w/Thermostat and Wall Bracket

3.3 kW through 15 kW horizontal discharge suspended fan forced unit heaters available in 1 or 3-phase for all standard voltages from 208V to 480V.



UHE Features

CONSTRUCTION:

Heavy gauge welded steel cabinet with powder coated finish and control compartment with a hinged and latched access door, simplifying wiring installation and maintenance

HEATING ELEMENT:

Circular copper clad steel sheath element with continuously brazed steel fins formed to match the air delivery pattern of the fan blade

OVERHEAT PROTECTION:

All units come equipped with automatic resetting type limit controls to de-energize the heater should an over-temperature situation occur

FAN and MOTOR:

Totally enclosed, single phase, permanently lubricated, thermally protected motors with unit bearings on 3 kW - 10 kW models and sleeve bearings on 12.5 kW - 15 kW models - mounted with rubber insulators to minimize vibration and noise. Fan assembly enclosed by a heavy gauge, close spaced, chrome plated wire guard

LOUVER ASSEMBLY:

Louvers are individually adjustable for directional control of air flow and the entire assembly can be repositioned in the field from down flow to up flow or left / right directional air flow

INSTALLATION:

Unit heaters can be mounted with the motor shaft from horizontal to downward at 45° off horizontal. Pre-drilled holes and installed threaded nuts provided to allow hanging by threaded rods - 1/4" for units up to 15 kW.

UHE Series Product Dimensions

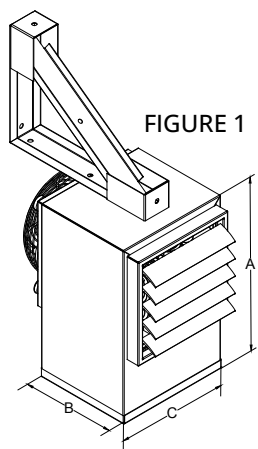

FIGURE 1



WARNING: This product can expose you to chemicals including nickel which is known to the State of California to cause cancer, and chromium, which is known to the State of California to cause birth defects and/or reproductive harm. For more information go to www.P65Warnings.ca.gov.

DIMENSIONS	A	B	C
Figure 1: 3.3, 5, 7.5, 10 KW	20"	11"	13"
Figure 2: 12.5, 15 KW	22"	11"	15"
MAXIMUM RECOMMENDED MOUNTING HEIGHT			
3 - 10 KW	9 FT		
12 - 15 KW	10 FT		

NOTE: 3.3 kW through 15 kW units can be mounted using 1/4 threaded rod.

HOW TO DESIGNATE A MODEL:

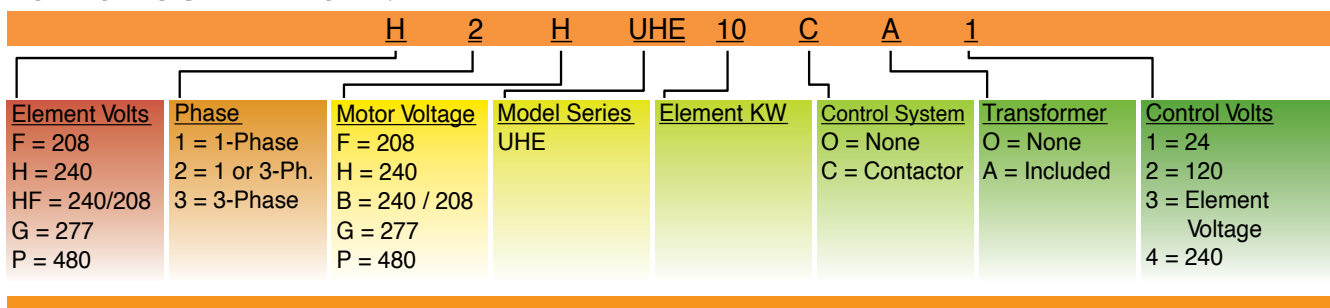

UHE Series Horizontal Fan Forced Unit Heater

UHE Series Standard Products

MFG CATALOG NUMBER	MFG MODEL NUMBER	KW	BTUs	VOLTS	PH	AMPS	CONTROL VOLTS	TEMP RISE °F	AIR THROW	CFM	WT. (LBS)	LIST
07421302	F1FUHE03003T	3.33	11200	208	1	16.3	208	26	26'	400	36	1300
07421702	F3FUHE03C03T	3.33	11200	208	3	9.5	208	26	26'	400	36	1300
07421402	H1HUHE03003T	3.33	11200	240	1	14.2	240	26	26'	400	36	1300
07421602	H3HUHE03C03T	3.33	11200	240	3	8.2	240	26	26'	400	36	1300
07421502	G1GUHE03003T	3.33	11200	277	1	12.3	277	26	26'	400	36	1300
07421802	P3PUHE03CA1T	3.33	11200	480	3	4.1	24	26	26'	400	36	1586
07421902	F1FUHE05003T	5	17100	208	1	24.3	208	40	26'	400	36	1496
07422202	F2FUHE05C03T	5	17100	208	1/3	24/13.9	208	40	26'	400	44	1496
07422002	H1HUHE05003T	5	17100	240	1	21.1	240	40	26'	400	36	1496
07422302	H2HUHE05C03T	5	17100	240	1/3	20.8/12.0	240	40	26'	400	44	1496
07422102	G1GUHE05003T	5	17100	277	1	18.3	277	40	26'	400	36	1496
07422402	P3PUHE05CA1T	5	17100	480	3	6.2	24	40	26'	400	44	1700
07422502	F1FUHE07CA1T	7.5	25600	208	1	36.7	24	42	36'	575	40	1748
07422802	F3FUHE07C03T	7.5	25600	208	3	21.4	208	42	36'	575	44	1748
07422602	H1HUHE07CA1T	7.5	25600	240	1	31.8	24	42	36'	575	41	1748
07422902	H2HUHE07C03T	7.5	25600	240	1/3	31.1/18.0	240	42	36'	575	44	1748
07422702	G1GUHE07CA1T	7.5	25600	277	1	27.6	24	42	36'	575	41	1748
07423002	P3PUHE07CA1T	7.5	25600	480	3	9.3	24	42	36'	575	44	2067
07423102	F1FUHE10CA1T	10	34100	208	1	48.7	24	55	36'	575	42	2106
07423402	F2FUHE10C03T	10	34100	208	1/3	48.0/27.8	208	55	36'	575	42	2106
07423202	H1HUHE10CA1T	10	34100	240	1	42.2	24	55	36'	575	42	2106
07423502	HF2BUHE10C03T	10.0/7.5	34100 / 25600	240/208	1/3	41.7/2 or 36.1/20.8	240/208	55/42	36'	575	45	2106
07423302	G1GUHE10RA1T	10	34100	277	1	36.6	24	55	36'	575	42	2106
07423602	P3PUHE10CA1T	10	34100	480	3	12.3	24	55	36'	575	51	2174
07423702	F1FUHE12C03T	12.5	42600	208	1	60.9	208	49	45'	800	45	3230
07423902	F3FUHE12C03T	12.5	42600	208	3	35.5	208	49	45'	800	45	3230
07423802	H1HUHE12C03T	12.5	42600	240	1	52.8	240	49	45'	800	45	3230
07424002	H3HUHE12C03T	12.5	42600	240	3	30.8	240	49	45'	800	45	3230
07424102	P3PUHE12CA1T	12.5	42600	480	3	15.6	24	49	45'	800	45	3350
07424202	F1FUHE15C03T	15	51200	208	1	72.9	208	59	45'	800	54	3530
07424402	F3FUHE15C03T	15	51200	208	3	42.4	208	59	45'	800	54	3530
07424302	H1HUHE15C03T	15	51200	240	1	63.3	240	59	45'	800	54	3530
07424502	H3HUHE15C03T	15	51200	240	3	36.8	240	59	45'	800	54	3530
07424602	P3PUHE15CA1T	15	51200	480	3	18.6	24	59	45'	800	54	3659

5100 Series Horizontal or Vertical Mounted Fan Forced Unit Heater

3.3 KW THROUGH 50 KW SUSPENDED FAN FORCED UNIT HEATERS AVAILABLE IN 1 OR 3 PHASE FOR ALL STANDARD VOLTAGES FROM 208V TO 480V THAT CAN BE MOUNTED TO PROVIDE HORIZONTAL OR VERTICAL DISCHARGE



Horizontal Discharge



Vertical Discharge

Taskmaster Dimensions

KW RATING	DIMENSIONS (inches)		
	H	W	D
3.3 - 5.0	17 ¾	14 15/32	6 ½
7.5 - 10.0	24 ¾	21 ½	6 ½
15.0 - 20.0	28 11/16	21 ½	6 ½
25.0 - 50.0	34	29 ¼	10 1/16

CONSTRUCTION:

Heavy 18 gauge welded steel cabinet with powder coated finish and control compartment housing a master terminal board with a hinged and latched access door, simplifying wiring, installation & maintenance.

HEATING ELEMENT:

Copper clad steel sheath element with continuously brazed steel fins formed to allow side draw through air flow.

OVERHEAT PROTECTION:

All units come equipped with automatic reset type limit controls to de-energize the heater should an over-temperature situation occur.

FAN & MOTOR:

Totally enclosed, 1-speed, 1-phase, permanently lubricated, thermally protected motors with unit bearings on 3 kW - 20 kW models. Totally enclosed, 2-speed, 1-phase, permanently lubricated, thermally protected motors with sleeve bearings on 25 kW - 50 kW models. Fan over-ride purges unit of residual heat at shutdown.

LOUVER ASSEMBLY:

Louvers are individually adjustable for directional control of air flow up to 15° from straight horizontal. Optional diffusers available for down flow (vertical discharge) applications.

TEMPERATURE CONTROLS:

Optional low voltage and line voltage thermostats available with an adjustable temperature range of 40°F to 110°F. Units with model numbers ending in CA1 are factory wired for low voltage controls. 25 kW through 50 kW units are designed for two stage heating operation.

INSTALLATION:

Unit Heaters can be mounted for horizontal or vertical discharge. Applications up to 6000 ft. See UH Series above 6000 ft.

FIELD INSTALLED OPTIONS:

- In-unit or wall mounted temperature control thermostats low or line voltage
- Summer fan switch to operate the fan only
- Power disconnect switch
- Heat stratification thermostat

Installing the Taskmaster Series

DETERMINING HEATER REQUIREMENTS

Calculate the heating loads using the NEMA handbook or ASHRAE guide. Then determine the quantity and size of unit heaters to be used. To maintain uniform heat and reduce stratified air, it is recommended that the total CFM of the units turn the air over approximately 3 times per hour. In instances where a large group of people are located and normally in the same area, use a large number of lower kW unit heaters. In warehouse areas or storage rooms where heat distribution and constant temperatures are less important, use fewer heaters of higher capacity.

HORIZONTAL MOUNT

Small rooms can be heated by one unit heater. Where two walls are exposed, heaters should be mounted as shown in Figure A. In larger rooms, units should be located so their air streams wipe exposed walls without blowing at them. Units should be located so that the air stream of one supports that of another thus setting up a circulatory air movement shown in Figure B. (Distance between units to be approximately 1-1/2 times published air throw.) Units should not be mounted horizontally in areas having ceiling heights in excess of 15-18 ft.

VERTICAL MOUNT

Units should be mounted vertically in high bay areas, or where heater location would not interfere with plant operation or traffic. Heaters should be situated to provide free air circulation. Size and selection of units should be based on recommended mounting height. Optional diffusers may best be employed to reduce high air velocity and at the same time disperse heated air in a uniform pattern. When unit heaters are used to combat cold air inrush from opened loading dock doors, one or more units should be arranged to blow warm air across opening (Figure C).

DUAL MOUNTING

Where square footage is large and comfort essential, both horizontal and vertical installations may best serve your requirements as Figure D demonstrates.

Note: Products in this section with factory installed controls are subject to 100% cancellation/restocking charges.

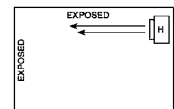

Figure A

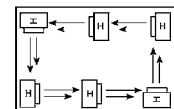

Figure B

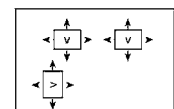

Figure C

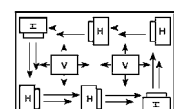
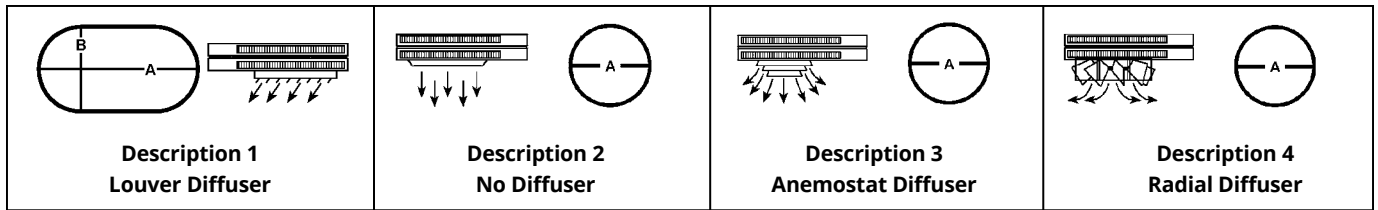

Figure D

5100 Series Horizontal or Vertical Mounted Fan Forced Unit Heater

Diffuser Options

DESCRIPTION	MFG CATALOG NUMBER	MFG MODEL NUMBER	KW USED	MAX MOUNTING HEIGHT (ft.)	DIMENSION A (feet)		DIMENSION B (feet)		WT. (LBS)	LIST	
Louver Diffuser (Standard) Louvers can be individually adjusted for rectangular coverage over doorways as an air curtain, or to meet rectangular floor pattern heating requirements.	NA	Standard	3.3-5 7.5-10 25-30 40-50	9	20		10		NA	NA	
				12	40		22				
				18	52		30				
				22	75		42				
				24	84		47				
General Distribution (No Diffuser) The 5100 air chute venturi permits general down flow air pattern distribution as required at a higher mounting height.	NA	Not Required	3.3-5 7.5-10 25-30 40-50	9	15		NA		NA	NA	
				12	30						
				18	40						
				22	55						
				24	64						
Anemostat Diffuser (Optional) For applications where draft restriction is required at lower unit mounting heights.	06926802	AD5120	10-20	15	38		NA		10	651	
	06811802	AD5150	25-30	17	50				12	973	
	06811802	AD5150	40-50	20	60				37	1046	
	07220702	AD5175	60-70	31	-						
Radial Diffuser (Optional) Individually adjustable fins permit increased floor coverage at 45° open. Additional throw is accomplished when fins are 90° vertical. (Please allow for higher mounting heights.)	06926602 06926602 06926702 06926702 07220802	RD5120 RD5120 RD5150 RD5150 RD5175	7.5-20 25-50 60-70	45°	90°	45°	90°	NA		12	721
				10	14	36	30				721
				14	21	42	35			14	846
				20	30	62	44				
				18	28	68	54				
				26	36	72	60			39	908



Mounting Brackets & Model Designator

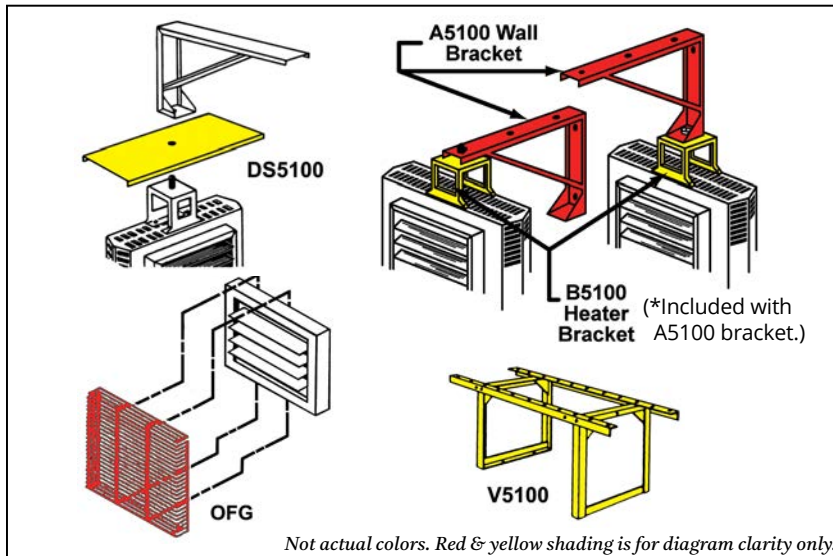

MOUNTING BRACKETS				
MFG CATALOG NUMBER	MFG MODEL NUMBER	MODEL SIZE	WT. (LBS)	LIST
06926902	A5105	3.3 KW TO 5.0 KW	9	177
06927002	A5120	7.5 KW TO 20.0 KW	13	203
06927102	A5150	25.0 KW TO 50.0 KW	16	240
06886202	B5105	3.3 KW TO 20.0 KW	3	92
06886302	B5150	25.0 KW TO 50.0 KW	8	134
06928402	V5105	3.3 KW TO 5.0 KW	9	341
06928502	V5120	7.5 KW TO 20.0 KW	13	420
06928602	V5150	25.0 KW TO 50.0 KW	16	443
DUST SHIELD				
06928702	DS5105	3.3 KW TO 5.0 KW	3	66
06928802	DS5120	7.5 KW TO 20.0 KW	4	72
06812202	DS5150	25.0 KW TO 50.0 KW	5	78
FAN GUARD				
07065402	OFG5101	3.3 KW TO 5.0 KW	3	98
07065502	OFG5102	7.5 KW TO 20.0 KW	4	107
07065602	OFG5103	25.0 KW TO 50.0 KW	5	125

HOW TO DESIGNATE A MODEL:

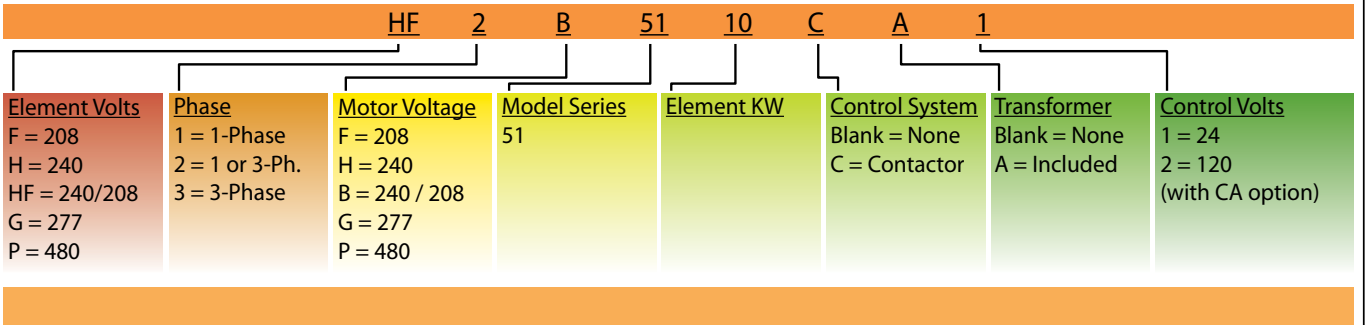

5100 Series Horizontal or Vertical Mounted Fan Forced Unit Heater

Standard Taskmaster Models & Series Notes

MFG CATALOG NUMBER	MFG MODEL NUMBER	KW	BTU / H	VOLTS	PH	AMPS	CONTROL VOLTAGE	TEMP RISE	AIR THROW	CFM	RECOMMENDED MOUNTING HT.		WT. (LBS)	LIST
											Horizontal	Vertical		
06450802	F1F5103N	3.3	11.2	208	1	15.9 / 9.17	208	26°F	12'	400	9'	9'	25	1157
06451002	HF1B5103N	3.3/2.5	11.2 / 8.5	240/208	1	13.7 / 12.0	240 / 208	26°F	12'	400	9'	9'	25	1157
06456802	F2F5103N	3.3	11.2	208	1 / 3	15.9 / 9.17	208	26°F	12'	400	9'	9'	25	1157
06457002	HF2B5103N	3.3/2.5	11.2 / 8.5	240/208	1 / 3	13.7 / 11.9	240 / 208	26°F	12'	400	9'	9'	25	1157
	HF2B5103N	3.3/2.5	11.2 / 8.5	240/208	3	7.9 / 6.9	240 / 208	26°F	12'	400	9'	9'	25	1157
06457202	G1G5103N	3.3	11.2	277	1	11.9	277	26°F	12'	400	9'	9'	25	1157
06451202	P3P5103CA1N*	3.3	11.2	480	3	4.0	24	26°F	12'	400	9'	9'	25	1475
06455402	F1F5105N	5.0	17.1	208	1	25.7	208	40°F	12'	400	9'	9'	25	1209
06455602	HF1B5105N	5.0/3.7	17.1 / 12.8	240/208	1	20.9 / 18.1	240 / 208	40°F	12'	400	9'	9'	25	1209
06451402	F2F5105N	5.0	17.1	208	1 / 3	25.7	208	40°F	12'	400	9'	9'	25	1209
06451402	F2F5105N	5.0	17.1	208	3	13.9	208	40°F	12'	400	9'	9'	25	1209
06451602	HF2B5105N	5.0	17.1	240	1 / 3	20.8 / 18.1	240	40°F	12'	400	9'	9'	27	1209
06451602	HF2B5105N	3.7	12.8	208	1 / 3	17.1 / 10.4	208	40°F	12'	400	9'	9'	27	1209
06458402	G1G5105N	5.0	17.1	277	1	18.1	277	40°F	12'	400	9'	9'	27	1209
06451802	P3P5105CA1N*	5.0	17.1	480	3	6.1		40°F	12'	400	9'	9'	27	1601
06452002	F2F5107CA1L*	7.5	25.6	208	1 / 3	36.1 / 20.8		34°F	22'	700	10'	12'	54	1863
06452202	HF2B5107CA1L*	7.5	25.6	240	1 / 3	27.1 / 16.04		34°F	22'	700	10'	12'	54	1863
06452202	HF2B5107CA1L*	5.6	19.2	208	1 / 3	31.3 / 27.1		34°F	22'	700	10'	12'	54	1863
06459202	G1G5107CA1L*	7.5	25.6	277	1	27.1		34°F	22'	700	10'	12'	54	1863
06452402	P3P5107CA1N*	7.5	25.6	480	3	9.1		34°F	22'	700	10'	12'	54	2009
06452602	F2F5110CA1L*	9.9	33.8	208	1 / 3	47.8 / 27.4		45°F	22'	700	10'	14'	55	2053
06452802	HF2B5110CA1L*	10.0	34.1	240	1 / 3	41.2 / 24.0		45°F	22'	700	10'	14'	55	2053
06452802	HF2B5110CA1L*	7.5	25.6	208	1 / 3	36.1 / 20.8		45°F	22'	700	10'	14'	55	2053
06456402	G1G5110CA1L*	10.0	34.1	277	1	36.1		45°F	22'	700	10'	14'	55	2053
06453002	P3P5110CA1N*	10.0	34.1	480	3	12.4		45°F	22'	700	10'	14'	55	2129
06453202	F3F5115CA1L*	15.0	51.2	208	3	41.7		45°F	22'	1100	10'	14'	64	3303
06453402	HF3B5115CA1L*	15.0/11.2	51.2 / 38.4	240/208	3	36.1 / 31.3		43°F	32'	1100	11'	20'	64	3303
06453602	P3P5115CA1N*	15.0	51.2	480	3	18.1		43°F	32'	1100	11'	20'	64	3435
06453802	HF3B5120CA1L*	19.7/14.8	67.2 / 50.5	240/208	3	47.8 / 41.1		57°F	32'	1100	12'	18'	65	4533
06454002	P3P5120CA1N*	20.0	68.3	480	3	25.7		57°F	32'	1100	12'	18'	65	4533
06458802	F3F5125CA1L*	25.0	85.3	208	3	69.5		57°F	32'	2000/1800	12'	18'	65	5344
06459802	P3P5125CA1N*	25.0	85.3	480	3	30.1		57°F	32'	2000/1801	12'	18'	65	5344
06454202	F3F5130CA1L*	30.0	102.4	208	3	83.4		57°F	32'	2000/1802	12'	18'	65	6183
06454402	HF3B5130CA1L*	30.0/22.5	102.4 / 76.8	240/208	3	72.3 / 62.5		47/53°F	40'	2000/1803	12'	20'	120	6183
06454602	P3P5130CA1N*	30.0	102.4	480	3	36.2		47/53°F	40'	2000/1804	12'	20'	120	6183
06440402	F3F5140CA1L*	40.0	136.5	208	3	111.2		47/53°F	40'	2000/1805	12'	20'	120	7908
06440602	HF3B5140CA1L*	40.0/30.0	136.5/102.4	240/208	3	96.4 / 83.4		40/45°F	55'	3100/2800	15'	24'	120	7908
06440802	P3P5140CA1N*	39.0	133.1	480	3	47.0		40/45°F	55'	3100/2801	15'	24'	120	7908
06454802	F3F5150CA1L*	49.6	169.3	208	3	139.0		40/45°F	55'	3100/2802	15'	24'	120	9869
06455002	HF3B5150CA1L*	50.0/37.5	170.6/128.0	240/208	3	120.5/104.3		51/56°F	50'	3100/2800	15'	22'	120	9869
06455202	P3P5150CA1N	50.0	170.6	480	3	60.3		51/56°F	50'	3100/2801	15'	22'	120	9869

International Models

MFG CATALOG NUMBER	MFG MODEL NUMBER	KW	BTU / H	VOLTS	PH	AMPS	CONTROL VOLTAGE	TEMP RISE	AIR THROW	CFM	RECOMMENDED MOUNTING HT.		WT. (LBS)	LIST		
											Horizontal	Vertical				
07153002	Q3H5103CA1	3.3	11263	380	3	5.02	24	26	12'	400	9'	9'	25	1190		
07249202	R3H5103CA1	3.3	11263	415		4.6		26	12'	400	9'	9'	9'	25	1516	
07249302	Q3H5105CA1	5.0	17065	380		7.6		40	12'	400	9'	9'	9'	27	1243	
04249402	R3H5105CA1	5.0	17065	415		6.96		40	12'	400	9'	9'	9'	27	1644	
07171302	Q3H5107CA1	7.5	25600	380		11.4		34	22'	700	10'	12'	10'	12'	54	1917
07249502	R3H5107CA1	7.5	25600	415		10.5		34	22'	700	10'	12'	10'	12'	54	2069
06865702	Q3H5110CA1	10.0	34130	380		15.2		45	22'	700	10'	14'	10'	14'	55	2112
07249602	R3H5110CA1	10.0	34130	415		13.9		45	22'	700	10'	14'	10'	14'	55	2190

- For 24V control add "CA1" suffix and \$145 list. • For 120V control add "CA2" suffix and \$145 list.
- For other voltages consult factory.

NOTES:

- 25-50KW models are wired for single or two stage heating and have two speed motors.
- Air delivery and motor data on dual voltage units reflect higher voltage.
- 600V models available 5-48.5 KW. Use "U" prefix to designate 600v and use 480v pricing + 20% adder.
- Supply wire on 40 and 50 KW models should have rated insulation of 75°C minimum.
- Use T5122 for two stage control.
- Use Pro T721 for two stage control.
- Use TFS5102 for two stage control.
- Wall thermostat must be used when built-in stratification thermostat is required

5100 Series Horizontal or Vertical Mounted Fan Forced Unit Heater

Recommended Control Options, Control Accessory Options, & Control Accessories

MFG MODEL NUMBER	DISCONNECT SWITCH		THERMOSTAT		SUMMER FAN SWITCH		THERMOSTAT & SUMMER FAN SWITCH WALL MOUNTED	STRATIFICATION THERMOSTAT	
	1 Ø	3 Ø	IN-BUILT	WALL MOUNTED	IN-BUILT	WALL MOUNTED		IN-BUILT	WALL MOUNTED
F1F5103N	DCS 202	NA	T5100	ET9STS	FS5101	FSW5111	NA	TC5103	TC1602
HF1B5103N	DCS 203	NA	T5100	ET9STS	FS5101	FSW5111	NA	TC5103	TC1602
F2F5103N	DCS 204	NA	T5100	ET9STS	FS5101	FSW5111	NA	TC5103	TC1602
F2F5103N	NA	DCS 403	T5102	TW 1512	FS5101	FSW5111	NA	TC5103	TC1602
HF2B5103N	DCS 202	NA	T5100	ET9STS	FS5101	FSW5111	NA	TC5103	TC1602
HF2B5103N	NA	DCS 403	T5102	TW 1512	FS5101	FSW5111	NA	TC5103	TC1602
HF2B5103N	DCS 202	NA	T5100	ET9STS	FS5101	FSW5111	NA	TC5103	TC1602
P3P5103CA1N	NA	DCS 403	T5100	RK120EAA	FS5102	FSW5112	TF55101	TC5102	NA
F1F5105N	DCS 403	NA	T5100	S2025	FS5101	FSW5111	NA	TC5103	TC1602
HF1B5105N	DCS 404	NA	T5100	ET9STS	FS5101	FSW5111	NA	TC5103	TC1602
F2F5105N	DCS 405	NA	T5100	S2025	FS5101	FSW5111	NA	TC5103	TC1602
F2F5105N	NA	DCS 403	T5102	TW 1512	FS5101	FSW5111	NA	TC5103	TC1602
HF2B5105N	DCS 403	NA	T5100	ET9STS	FS5101	FSW5111	NA	TC5103	TC1602
HF2B5105N	NA	DCS 403	T5102	TW 1512	FS5101	FSW5111	NA	TC5103	TC1602
G1G5105N	DCS 403	NA	T5100	S2025	FS5101	FSW5111	NA	TC5103	TC1602
P3P5105CA1N	NA	DCS 403	T5100	RK120EAA	FS5102	FSW5112	TF55101	TC5102	NA
F2F5107CA1L	DCS 603	NA	T5100	RK120EAA	FS5101	FSW5111	TF55101	TC5103	TC1602
F2F5107CA1L	NA	DCS 603	T5100	RK120EAA	FS5101	FSW5111	TF55101	TC5103	TC1602
HF2B 5107CA1L	DCS 403	NA	T5100	RK120EAA	FS5101	FSW5111	TF55101	TC5103	TC1602
HF2B 5107CA1L	NA	DCS 403	T5100	RK120EAA	FS5101	FSW5111	TF55101	TC5103	TC1602
G1G5107CA1L	DCS 403	NA	T5100	RK120EAA	FS5101	FSW5111	TF55101	TC5103	TC1602
P3P5107CA1L	NA	DCS 403	T5100	RK120EAA	FS5102	FSW5112	TF55101	TC5102	NA
F2F5110CA1L	DCS 603	NA	T5100	RK120EAA	FS5101	FSW5111	TF55101	TC5103	TC1602
F2F5110CA1L	NA	DCS 603	T5100	RK120EAA	FS5101	FSW5111	TF55101	TC5103	TC1602
HF2B5110CA1L	DCS 603	NA	T5100	RK120EAA	FS5101	FSW5111	TF55101	TC5103	TC1602
HF2B5110CA1L	NA	DCS 603	T5100	RK120EAA	FS5101	FSW5111	TF55101	TC5103	TC1602
G1G5110CA1N	DCS 603	NA	T5100	RK120EAA	FS5101	FSW5111	TF55101	TC5103	TC1602
P3P5110CA1N	NA	DCS 403	T5100	RK120EAA	FS5102	FSW5112	TF55101	TC5103	NA
F3F5115CA1L	NA	DCS 603	T5100	RK120EAA	FS5101	FSW5111	TF55101	TC5103	TC1602
HF3B5115CA1L	NA	DCS 603	T5100	RK120EAA	FS5101	FSW5111	TF55101	TC5103	TC1602
P3P5115CA1L	NA	DCS 403	T5100	RK120EAA	FS5102	FSW5112	TF55101	TC5103	NA
HF3B5120CA1L	NA	DCS 603	T5100	RK120EAA	FS5101	FSW5111	TF55101	TC5103	TC1602
P3P5120CA1N	NA	DCS 403	T5100	RK120EAA	FS5102	FSW5112	TF55101	TC5103	NA
F3F5125CA1L	NA	DCS 1003	T5100	T721	FS5101	FSW5111	TF55101	TC5103	TC1602
HF3B5125CA1L	NA	DCS 1004	T5100	T721	FS5101	FSW5111	TF55101	TC5103	TC1602
P3P5125CA1N	NA	DCS 403	T5100	T721	FS5102	FSW5112	TF55101	TC5103	NA
F3F5130CA1L	NA	NA	T5100	T721	FS5101	FSW5111	TF55101	TC5103	TC1602
HF3B5130CA1L	NA	DCS 1003	T5100	T721	FS5101	FSW5111	TF55101	TC5103	TC1602
P3P5130CA1N	NA	DCS 603	T5100	T721	FS5102	FSW5112	TF55101	TC5103	NA
F3F5140CA1L	NA	NA	T5100	T721	FS5101	FSW5111	TF55101	TC5103	TC1602
HF3B5140CA1L	NA	NA	T5100	T721	FS5101	FSW5111	TF55101	TC5103	TC1602
P3P5140CA1N	NA	DCS 603	T5100	T721	FS5102	FSW5112	TF55101	TC5103	NA
F3F5150CA1L	NA	NA	T5100	T721	FS5101	FSW5111	TF55101	TC5103	TC1602
HF3B5150CA1L	NA	NA	T5100	T721	FS5101	FSW5111	TF55101	TC5103	TC1602
P3P5150CA1N	NA	DCS 1003	T5100	T721	FS5102	FSW5112	TF55101	TC5103	NA

CONTROL ACCESSORY OPTIONS - FIELD INSTALLED IN HEATER			
MFG CATALOG NUMBER	MFG MODEL NUMBER	DESCRIPTION	LIST
POWER DISCONNECT SWITCH*			
07171502	DCS202 / 5100	20 AMP; 0-16 Amps	151
07171602	DCS403 / 5100	40 AMP; 16.1-32 Amps	284
07171702	DCS603 / 5100	60 AMP; 32.1-48 Amps	397
07171802	DCS1003 / 5100	100 AMP; 48.1-80 Amps	444
*Disconnect must be rated at 80% of total ampload.			
LINE VOLTAGE THERMOSTAT			
06927702	T5100	SPST; PILOT DUTY 25 AMP, 24-277V, (40-110 °F)	210
06927802	T5102	DPST; LINE DUTY 25 AMP, 120-277V (40-120 °F)	284
LOW VOLTAGE THERMOSTAT (ALL CA1 MODELS)			
06927702	T5100	SPST; LOW VOLT/PILOT DUTY; 125VA; (3.3-20 KW UNITS), (40-110 °F)	210
06927902	T5122	2-STAGE; LOW VOLT; 125VA; (25-50 KW UNITS), (40-100 °F)	309
STRATIFICATION THERMOSTAT			
05239802	L00E-01	LINE DUTY; 22A; 125/250/277 VAC	357
06928002	TC5102	SPST; LOW VOLT/PILOT DUTY (W/RELAY); 70-130°	322
06928102	TC5103	SPST; LINE DUTY; AMP 120-240V; 70-130°	226
SUMMER FAN SWITCH			
06928202	FS5101	SPST; LINE VOLT; 120-277V	121
06928302	FS5102	SPST; LINE VOLT; 480-600V	173

CONTROL ACCESSORIES - REMOTE WALL MOUNTED			
MFG CATALOG NUMBER	MFG MODEL NUMBER	DESCRIPTION	LIST
LINE VOLTAGE THERMOSTAT			
05029102	S2025H10AA**	SP; 25 Amp; 120-277V; 50-90°F	88
05238902	ET9STS**	SP; 22 Amp; 120-277V; 50-90°F	45
06910902	TW1512*	DPST; 25 AMP; 120-277V; 50-90°F	332
LOW VOLTAGE THERMOSTATS (ALL CA1 MODELS)			
05260102	RK120EAA	24VAC or MV; 50-90°F (3.3-20kW)	33
07425202	PRO1 T721	DIGITAL; 24V; 1 or 2 STAGE; 44°-90°F	155
STRATIFICATION THERMOSTAT			
06911002	TC1602	SPST; LINE VOLT; 120-277V; 70-140°	357
SUMMER FAN SWITCH			
06926202	FSW5111	SPST; LINE VOLT; 120-277V	151
06926302	FSW5112	SPST; LOW VOLT; (W/RELAY)	322
324 LOW VOLTAGE THERMOSTAT & SUMMER FAN SWITCH (W/RELAY) (CA1 MODELS)			
06926402	TF55101	SPST; LOW VOLT; 50-90°	341
06926502	TF55102	ELECTRONIC; 1 OR 2 STAGE; LOW VOLT; 40° - 90°F	678

*Use DPST double line break thermostat for 3-phase line voltage control in non "C" models. **Any SPST thermostat of sufficient amperage may be substituted. *** For complete specifications, refer to page 108.

5100 Series 60 kW -100 kW Suspended Fan Forced Unit Heater

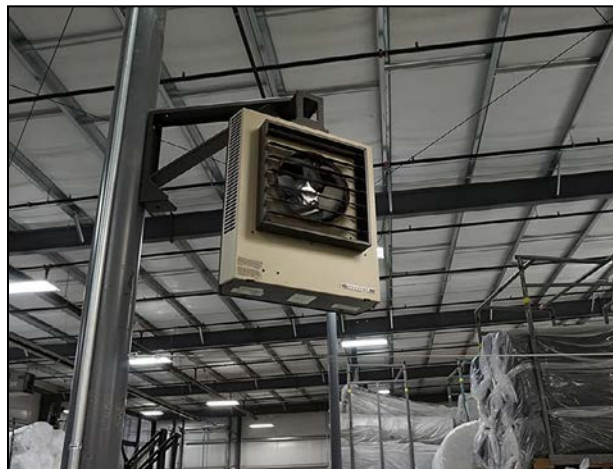

WARNING: This product can expose you to chemicals including nickel which is known to the State of California to cause cancer, and chromium, which is known to the State of California to cause birth defects and/or reproductive harm. For more information go to www.P65Warnings.ca.gov.



Features & Specifications

CONSTRUCTION:

Heavy gauge steel cabinet with powder coated finish and control compartment housing a master terminal board. The control compartment allows for access through a hinged and latched door, simplifying wiring, installation, and maintenance. Made in U.S.A.

HEATING ELEMENT:

The heating element is a copper clad steel sheath element with continuously brazed steel fins formed to allow side draw through air flow.

OVERHEAT PROTECTION:

All units come equipped with manual reset type limit controls to de-energize the heater should an over-temperature situation occur.

FAN & MOTOR:

Single speed, single phase permanently lubricated, thermally protected motors with ball bearings. The fan override purges the unit of residual heat at shutdown.

FIELD INSTALLED OPTIONS:

Summer fan switch to operate the fan only, and a heat stratification thermostat for high bay areas.

HEATER STAGING:

60 kW and 70 kW are three stage; 80 kW, 90 kW, & 100 kW are four stage.

SC5100 FACTORY INSTALLED ELECTRONIC STEP CONTROLLER:

The optional factory installed step controller is a first on last off sequencer that will cycle the unit heater stages through an optional wall thermostat. Additionally, the step controller can be controlled by any building management system with 4 to 20 MA or 0 - 10 VDC field supplied control signal.

KW	DIMENSIONS (INCHES)			WT. (LBS)
	H	W	D	
60-70	35 ½	30 ½	14 ½	141
80-100	39 ½	37 ¾	18 ½	202

Mounting Brackets and Accessories

MOUNTING BRACKETS				
MFG CATALOG NUMBER	MFG MODEL NUMBER	KW	DESCRIPTION	LIST
07220002	A5175	60 To 70	Wall/Ceiling Bracket	327
07220102	A51100	80 to 100		349
07220302	B5175	60 to 70	Heater Bracket	144
07220402	B51100	80 to 100		178
07220202	V51100	60 to 100	Vertical Bracket	539
07220502	DS5175	60 to 70	Dust Shield	87
07220602	DS51100	80 to 100		98
07220902	OFG 5175	60 to 70	Fan Guard	135
07221002	OFG 51100	80 to 100		168

5100 Series 60 kW - 100 kW Suspended Fan Forced Unit Heater

Optional Factory Installed Electronic Step Controller

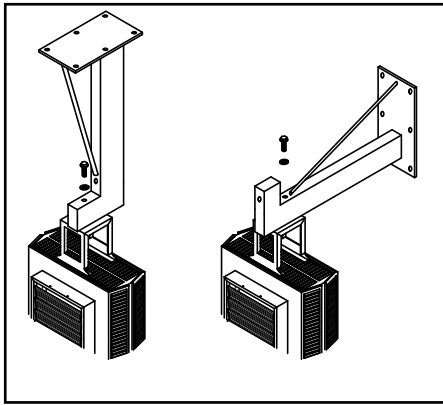

WALL / CEILING BRACKET

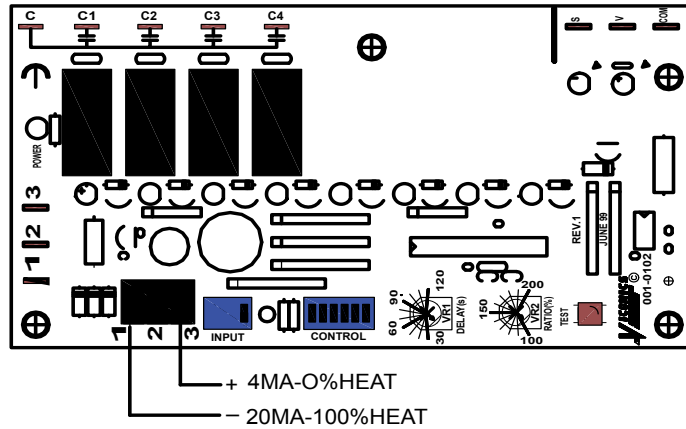

3 OR 4 STAGE
STEP CONTROL

0-10VDC-CONTROL
or VT7225
THERMOSTAT

Electrical Data

MFG CATALOG NUMBER	MFG MODEL NUMBER	KW	BTU/HR (x 1000)	VOLTS	PHASE	CONTROL VOLTAGE	AMPS / PHASE	BRANCH CIRCUIT PROTECTION SIZE	LIST
07213402	F3F5160CA1	60	204.7	208	3	24	166.7	225	13563
07213502	HF3B5160CA1	60/45	204.7/153.6	240/208	3	24	144.6/125	200/175	13563
07213602	P3P5160CA1	60	204.7	480	3	24	72.3	100	13563
07214202	F3F5170CA1	70	238.9	208	3	24	194.4	250	14139
07214302	HF3B5170CA1	70/52.5	238.9/179.2	240/208	3	24	168.7/145.8	225/200	14139
07214402	P3P5170CA1	70	238.9	480	3	24	84.3	110	14139
07217002	HF3B5180CA1	80/60	273/204.7	240/208	3	24	192.8/166.7	250/225	16525
07217102	P3P5180CA1	80	273	480	3	24	96.3	125	16525
07217602	HF3B5190CA1	90/67.5	307.1/230.4	240/208	3	24	216.9/187.5	300/250	17191
07217702	P3P5190CA1	90	307.1	480	3	24	108.4	150	17191
07218202	HF3B51100CA1	100/75	341.3/256	240/208	3	24	241/208.3	350/300	18149
07218302	P3P51100CA1	100	341.3	480	3	24	120.4	175	18149

Air Delivery Data

MFG CATALOG NUMBER	MFG MODEL NUMBER	CFM at OUTLET	FPM at OUTLET	TEMP RISE °F	HP	MOTOR RPM	AIR THROW	MAX MOUNTING	
								Horizontal	Vertical
07213402	F3F5160CA1	3400	1485	60	1/3	1100	50'	18'	31'
07213502	HF3B5160CA1			60/45					
07213602	P3P5160CA1			60					
07214202	F3F5170CA1			70					
07214302	HF3B5170CA1			70/53					
07214402	P3P5170CA1			70					
07217002	HF3B5180CA1	5000	1529	55/41	3/4	1100	65'	22'	40'
07217102	P3P5180CA1			55					
07217602	HF3B5190CA1			61/46					
07217702	P3P5190CA1			61					
07218202	HF3B51100CA1			68/51					
07218302	P3P51100CA1			68					

Recommended Control Options

MFG CATALOG NUMBER	MFG MODEL NUMBER	STEP CONTROLLER		REMOTE THERMOSTAT		SUMMER FAN SWITCH				STRATIFICATION THERMOSTAT			
		CATALOG/ MODEL	LIST	CATALOG/ MODEL	LIST	Wall		Built-In		Wall		Built-In	
						CATALOG/ MODEL	LIST	CATALOG/ MODEL	LIST	CATALOG/ MODEL	LIST	CATALOG/ MODEL	LIST
07213402	F3F5160CA1	05232302 SC5100	1123	44046001 VT7225 (0-10VDC)	308	06926302 FSW5112	322	FS5101	107	06926402 TF55101	341	06928002 TC5102	322
07213502	HF3B5160CA1							FS5101	107				
07213602	P3P5160CA1							FS5102	152				
07214202	F3F5170CA1							FS5101	107				
07214302	HF3B5170CA1							FS5101	107				
07214402	P3P5170CA1							FS5102	107				
07217002	HF3B5180CA1							FS5101	107				
07217102	P3P5180CA1							FS5102	152				
07217602	HF3B5190CA1							FS5101	107				
07217702	P3P5190CA1							FS5102	152				
07218202	HF3B51100CA1							FS5101	107				
07218302	P3P51100CA1							FS5102	152				

Note: Products listed in this section are custom built and subject to 100% cancellation/restocking charges.

2600 Series Downflow Unit Heater

General Description & Diffuser Information

CONSTRUCTION:

- 16 gauge steel cabinet with epoxy powder coated finish and control compartment with a hinged and latched access door.
- OSHA guards standard with all models.
- Made in U.S.A

HEATING ELEMENT:

- Corrosion resistant element with steel sheath and steel spiral fins.

OVERHEAT PROTECTION:

- All units come equipped with manual reset limit controls to de-energize the heater should an over-temperature situation occur.

FAN and MOTOR:

- Totally enclosed, 1 speed, 1 phase permanently lubricated, thermally protected motors with unit bearings on 3KW - 20KW models. Totally enclosed, 2 speed, 1 phase permanently lubricated, thermally protected motors with sleeve bearings on 24KW - 50KW models.
- Axial flow fan blade - 1570 RPM max.
- All models equipped with fan purge which allows fan to operate after elements are de-energized to purge residual heat.

TEMPERATURE CONTROLS:

- 208V, 240V, 277V and 480V units have In-Built 24 Volt transformer for low voltage remote thermostat application.
- 600V units have In-Built 240V control on 5-20 KW models, 25-50 KW models have 24V control.
- 25 KW - 50 KW models may operate as 2 stage heaters if 2 stage remote thermostat is used.

DISCONNECT SWITCH:

- All models equipped with In-Built disconnect except F3F2640, F3F2630CA1, F3F2650, H3H2650, and H3H2640CA1

INSTALLATION:

- Unit can be mounted using optional mounting bracket or field constructed angle iron bracket.
- Not recommended for mounting with threaded rod or chain.

2600 Series shown with standard wire guard. Diffusers are field installed.



WARNING: This product can expose you to chemicals including nickel which is known to the State of California to cause cancer, and chromium, which is known to the State of California to cause birth defects and/or reproductive harm. For more information go to www.P65Warnings.ca.gov.

Diffuser Descriptions	Standard Heater		Radial Louvered Cone Diffuser				Linear Louvered Diffuser			Anemostat Diffuser																
	<table border="1"> <thead> <tr> <th colspan="3">Dimensions**</th> </tr> <tr> <th>KW</th> <th>B</th> <th>A</th> </tr> </thead> <tbody> <tr> <td>5-20</td> <td>20 1/2"</td> <td>15"</td> </tr> <tr> <td>25-50</td> <td>27"</td> <td>21 1/2"</td> </tr> </tbody> </table>		Dimensions**			KW	B	A	5-20	20 1/2"	15"	25-50	27"	21 1/2"	<p>For general distribution. Choice of other diffusers may be added after installation if required.</p> <p>O.S.H.A guard for fan blade D1604 for 2605-2620, & D1614 for 2625-2650 Do not use with other diffusers.</p>				<p>With vanes vertical, straightens air for higher mounting. Closed position for broad horizontal coverage. Adjustable for intermediate requirements.</p>			<p>Affords more precise directional throw where heaters cannot be mounted directly over area to be heated or for heating long narrow areas.</p>			<p>Blends room air with heated air for widespread distribution without excessive drafts.</p>	
	Dimensions**																									
KW	B	A																								
5-20	20 1/2"	15"																								
25-50	27"	21 1/2"																								
		VERTICAL		45 DEGREES OPEN																						
MODEL	MAX MOUNTING HEIGHT*	D (ft.)	MAX MOUNTING HEIGHT	D (ft.)	MAX MOUNTING HEIGHT	D (ft.)	MAX MOUNTING HEIGHT	W (ft.)	L (ft.)	MAX MOUNTING HEIGHT	D (ft.)															
2605	10	25	15	25	8	30	10	10	40	9	25															
2607	10	25	15	25	8	30	10	10	40	9	25															
2610	22	40	26	36	15	44	22	14	54	20	38															
2615	20	44	24	38	14	46	20	14	60	18	40															
2620	18	48	22	40	13	50	18	15	66	16	42															
2625	32	48	38	42	24	70	34	30	80	30	60															
2630	30	60	36	50	22	74	32	34	80	28	64															
2640	26	64	32	50	20	78	30	36	90	26	67															
2650	24	68	28	50	18	82	28	40	100	24	70															

* Minimum mounting height 6 feet.

** Dimensions are for all heater models without a diffuser option. Adding a diffuser will change the vertical ("A") dimension of heater. All mounting distances are in feet. All diagrams show optional mounting bracket.

2600 Series Downflow Unit Heater

Product Specifications

SPECIFICATIONS: The contractor shall furnish and install the 2600 Series electric vertical discharge unit heaters of the size, capacity and voltage specified. Heaters shall be installed according to the manufacturer's recommendations and applicable national and local codes.

ELEMENTS: Elements shall consist of Nickel Chromium alloy resistance wire embedded and completely surrounded in Magnesium Oxide, enclosed and swagged into corrosion resistant sheaths. Corrosion resistant steel fins shall be permanently attached to the sheaths to provide maximum heat transfer to the air stream.

MOTORS: Motors shall be single phase, resilient mounted, totally enclosed, industrial rated with an automatic reset thermal overload protective device. Motors on heaters up to 20 KW capacity shall be permanently lubricated shaded pole type. Over 20 KW, motors shall be permanent split capacitor type. Motors shall be mounted out of the main air stream in such a manner as to allow ambient air to be drawn over the motor to reduce motor temperature. Motor shall be separately removable from beneath the heater without removing the entire heater from mounting bracket.

FAN BLADES: Fan blades shall be heavy-duty individually balanced axial flow type. Fan speed shall not exceed 1570 RPM.

THERMAL OVERLOAD PROTECTION: All heaters shall be equipped with a manual reset thermal cutout which disconnects elements and motor in the event normal operating temperatures are exceeded.

WIRING: Heaters shall be designed for a single supply circuit with elements, motor and control circuits subdivided and fused to conform with the latest National Electric Code and OSHA requirements. All three phase heaters shall have balanced phases.

CONTROLS: Heaters shall be controlled by a low voltage wall mounted thermostat. All heaters 25 KW and larger shall be wired for 2 stage operation. 5 KW through 20 KW units are single stage. All heaters shall be equipped with a fan safety device that causes fan to operate after elements are de-energized to purge unit of residual heat.

Standard Models

MFG CATALOG NUMBER	MFG MODEL NUMBER	KW	BTUs	VOLTS	PH	AMPS	CONTROL VOLTS	TEMP RISE °F	CFM	WT (LBS)	LIST
07157502	F1F2605CA1	5	17065	208	1	24.03	24	34	490	75	1865
07157602	H1H2605CA1	5	17065	240	1	20.83		35	490	75	1865
07157702	G1G2605CA1	5	17065	277	1	18.05		36	490	75	1865
07157802	F3F2605CA1	5	17065	208	3	13.89		37	490	75	1865
07157902	H3H2605CA1	5	17065	240	3	12.04		38	490	75	1865
07158002	P3P2605CA1	5	17065	480	3	6.02		39	490	75	2282
07158202	F1F2607CA1	7.5	25598	208	1	36.05		45	560	75	2400
07158302	H1H2607CA1	7.5	25598	240	1	31.25		46	560	75	2400
07158402	G1G2607CA1	7.5	25598	277	1	27.07		47	560	75	2400
07158502	F3F2607CA1	7.5	25598	208	3	20.84		48	560	75	2400
07158602	H3H2607CA1	7.5	25598	240	3	18.06		49	560	75	2400
07158702	P3P2607CA1	7.5	25598	480	3	9.03		50	560	75	2636
07158902	F1F2610CA1	10	34130	208	1	48.07		26	1200	75	3285
07159002	H1H2610CA1	10	34130	240	1	41.66		26	1200	75	3285
07159102	G1G2610CA1	10	34130	277	1	36.1		26	1200	75	3285
07159202	F3F2610CA1	10	34130	208	3	27.79		26	1200	75	3285
07159302	H3H2610CA1	10	34130	240	3	24.08		26	1200	75	3285
07159402	P3P2610CA1	10	34130	480	3	12.04		26	1200	75	3875
07159602	F3F2615CA1	15	51195	208	3	41.68		39	1200	75	3756
07159702	H3H2615CA1	15	51195	240	3	36.12		39	1200	75	3756
07159802	P3P2615CA1	15	51195	480	3	18.06		39	1200	75	4228
07160002	H3H2620CA1	19.4	68260	240	3	48.16		52	1200	75	4345
07160102	P3P2620CA1	20	68260	480	3	24.08		52	1200	75	5112
07175102	F3F2625CA1	25	85325	208	3	69.48		24	3300	175	5781
07175202	H3H2625CA1	25	85325	240	3	60.21		24	3300	175	5781
07175302	P3P2625CA1	25	85325	480	3	30.1		24	3300	175	5900
07175502	F3F2630CA1*	30	102390	208	3	83.37		29	3300	175	6310
07175602	H3H2630CA1	30	102390	240	3	72.25		29	3300	175	6310
07175702	P3P2630CA1	30	102390	480	3	36.12		29	3300	175	7079
07175902	F3F2640CA1*	40	136520	208	3	111.17		38	3300	175	8377
07176002	H3H2640CA1*	40	136520	240	3	96.33		38	3300	175	8377
07176102	P3P2640CA1	40	136520	480	3	48.16		38	3300	175	8377
07176302	F3F2650CA1*	50	170650	208	3	138.96		48	3300	175	9558
07176402	H3H2650CA1*	50	170650	240	3	120.42		48	3300	175	9558
07176502	P3P2650CA1	50	170650	480	3	60.21		48	3300	175	9558

*Disconnect not available

Field Installed Accessories

MFG CATALOG NUMBER	MFG MODEL NUMBER	DESCRIPTION	LIST
06926302	FSW5112	Summer Fan Switch	322
07177502	A1600	Ceiling Mount Bracket 5-20 KW Models	205
07177602	A1601	Ceiling Mount Bracket 25-50 KW Models	229

MFG CATALOG NUMBER	MFG MODEL NUMBER	DESCRIPTION	LIST
07177902	D1602	Linear Louvered Diffuser 5-20 KW Models	685
07178002	D1612	Linear Louvered Diffuser 25-50 KW Models	1017
07178102	D1600	Radial Louvered Cone Diffuser 5-20 KW Models	756
07178202	D1610	Radial Louvered Cone Diffuser 25-50 KW Models	882
07178302	D1603	Anemostat Diffuser 5-20 KW Models	685
07178402	D1613	Anemostat Diffuser 25-50 KW Models	1017

5700 Series Confined Space Plenum Rated Heater



Features

- Easily fits between joists for typical installation
- Zero clearance for wall and ceiling mounting as well as floor mounting with appropriate inlet and outlet clearances
- Bracket standard or can be mounted by 3/8" threaded rod (field supplied)
- Automatic reset thermal limit for safety
- Single phase model wattage field changeable from 1874 to 5000 Watts
- 24V control circuit on three phase models with hydraulic thermostat
- Made in U.S.A

⚠ WARNING: This product can expose you to chemicals including nickel which is known to the State of California to cause cancer, and chromium, which is known to the State of California to cause birth defects and/or reproductive harm. For more information go to www.P65Warnings.ca.gov.



Product Dimensions

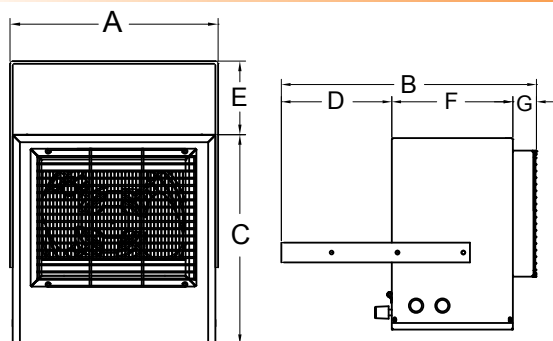

A	B	C	D	E	F	G
14.4"	19.4"	14.5"	8.4"	5.1"	9.2"	1.8"

Standard Models

MFG CATALOG NUMBER	MFG MODEL NUMBER	WATTS	BTUs	VOLTS	PHASE	AMPS	TEMP RISE	TEMP RANGE	AIR THROW	CFM	WT. (LBS)	LIST
7262402	HF5705T	5000	17065	240	1	21	57°	(40°F - 120°F)	16'	275	32	1276
		4165	14215	240	1	17	48°	(40°F - 120°F)	16'	275	32	1276
		3332	11365	240	1	14	38°	(40°F - 120°F)	16'	275	32	1276
		2500	8533	240	1	10	29°	(40°F - 120°F)	16'	275	32	1276
		3750	12798	208	1	18	43°	(40°F - 120°F)	16'	275	32	1276
		3123	10659	208	1	15	36°	(40°F - 120°F)	16'	275	32	1276
		2500	8553	208	1	12	29°	(40°F - 120°F)	16'	275	32	1276
7262502	H3H5705T	3750	12799	208	3	10.4	43°	(40°F - 110°F)	16'	275	32	1375
		5000	17065	240	3	12	57°	(40°F - 110°F)	16'	275	32	1375
7262602	P3P5705T	5000	17065	480	3	6	57°	(40°F - 110°F)	16'	275	32	1375
7073602	DCS-MT303	Optional Field Installed Disconnect Switch, 30 Amp @ 600Volts	17066	480	3	6	58°	(40°F - 110°F)	16'	275	32	118

5600 Series Multiple Wattage Fan Forced Unit Heater

Product Specifications

Casing & Construction: Fabricated of die formed, heavy gauge steel and finished with two tone, brown and beige, durable powder coated paint. Supply air is drawn through the rear heavy duty expanded steel inlet grill. Heated air is discharged through front adjustable louvers, which are spring loaded for individual adjustment. Made in U.S.A.

Element: Heavy-duty block fin element design. The multiple tap electric connection design allows field conversion to eight wattage settings at 208/240-Volt single phase or 240/480 Volt, 3 phase. Units are available on special order with a specific wattage/voltage setting.

Motor: Motor shall be totally enclosed, permanently lubricated, all angle industrial rated with thermal overload protection.

Wiring: Wiring to terminal block adjacent to incoming knockout in accordance with NEC and local codes.

Thermal Overload: All heaters shall be equipped with an automatic reset thermal cutout to shut down the element and motor circuits if unsafe operating temperatures are exceeded.

Controls: The heater shall have a heavy-duty hydraulic thermostat (with a temperature range of 40 °F-110 °F) factory installed and wired. All controls and wiring shall be in a large wiring compartment with hinged door for easy access. An optional disconnect switch shall be available for field installation.

Mounting: Heaters are standard with a three position-mounting bracket for wall, ceiling or workbench. Heaters can be mounted for horizontal or vertical discharge. Note: Minimum mounting height is 6 feet, and minimum distance from side of heater to nearest wall is 6 inches.

Note: Approved for residential applications



FRONT VIEW



WARNING: This product can expose you to chemicals including nickel which is known to the State of California to cause cancer, and chromium, which is known to the State of California to cause birth defects and/or reproductive harm. For more information go to www.P65Warnings.ca.gov.

Product Dimensions

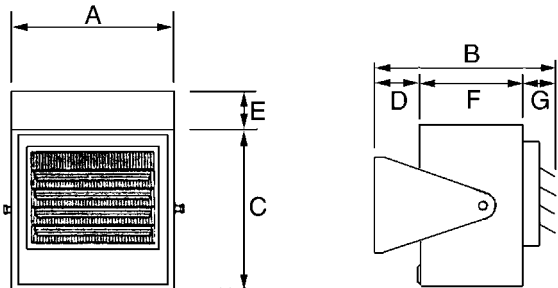

A	B	C	D	E	F	G
14"	12 11/16"	14"	1 9/16"	1 9/16"	9"	2 3/4"

Standard Models

MFG CATALOG NUMBER	MFG MODEL NUMBER	WATTS	BTUs	VOLTS	PHASE	AMPS	TEMP RISE	AIR THROW	CFM	WT. (LBS)	LIST
07072802	HF5605T	5000	17065	240	1	21	57 °F	16'	275	32	1276
		4165	14215	240	1	17	48 °F				1276
		3332	11365	240	1	14	38 °F				1276
		2500	8533	240	1	10	29 °F				1276
		3750	12798	208	1	18	43 °F				1276
		3123	10659	208	1	15	36 °F				1276
		2500	8553	208	1	12	29 °F				1276
		1874	6396	208	1	9	21 °F				1276
07072902	H3H5605T	3750	12799	208	3	10.4	43 °F				1375
07072902		5000	17065	240	3	12	57 °F				1375
07073002	P3P5605T	5000	17065	480	3	6	57 °F				1375
07073602	DCS-MT303	Optional Field Installed Disconnect Switch, 30 Amp @ 600Volts									118
For 24V control on single phase models delete "T" suffix											247

Product Specifications



WARNING: This product can expose you to chemicals including nickel which is known to the State of California to cause cancer, and chromium, which is known to the State of California to cause birth defects and/or reproductive harm. For more information go to www.P65Warnings.ca.gov.

The electric cabinet unit heater is designed for mounting in any position, fully recessed, semi-recessed or surface mounted. All capacities, voltages, physical sizes, grille arrangements and options shall be as specified on the plans. All units must be field convertible to the following:

1. For control by a field supplied remote thermostat.
2. Load management control with an external dry switch. When closed unit operates under control of either the internal or the external thermostat. When open, unit turns off.
3. Any grille arrangement.



CABINET & CONSTRUCTION: The cabinet shall be constructed of heavy duty 16 gauge Zinc coated steel. The heater shall have a removable front door for easy access to the control panel, elements, motor-blower assembly, filters and all internal components. The grill configuration must be easily field convertible to any air flow configuration (by removal of no more than four fasteners). The cabinet shall have a textured finish of two coats of powder coat epoxy and be suitable for use with optional kick space base. Made in U.S.A.

The heating elements shall be warranted for 1 year and shall be non-glowing design consisting of special high temperature resistance wire enclosed in an incoloy sheath to which steel fins are furnace brazed. The heating elements shall be located directly in front of the blower discharge air for uniform heating. They shall be mounted with a single anchor at one end to minimize effects of thermal expansion and contraction.

HEATING ELEMENTS: The heating elements shall be warranted for 1 year and shall be non-glowing design consisting of special high temperature resistance wire enclosed in an incoloy sheath to which steel fins are furnace brazed. The heating elements shall be located directly in front of the blower discharge air for uniform heating. They shall be mounted with a single anchor at one end to minimize effects of thermal expansion and contraction.

SAFETY CUTOFF: Thermal safety limits shall be built into the system to automatically shut off heater in event of overheating due to any cause. The safety cutouts shall be of two types:

- A. The primary limit shall be an automatic capillary type to sense the heat along the full length of the heating elements. It shall de-energize the heaters by opening the coil circuit on the heating contactors.
- B. The secondary limit shall be a manual reset thermal device to interrupt power to the heating elements

MOTOR AND BLOWER ASSEMBLY: The motors and blowers shall be direct drive and resiliently mounted on rigid heavy gauge frame for quiet operation and long life. The motor shall be two-speed, shaded pole type, rated for the voltage (480 to 600 Volts are single speed only). Each shall have built-in automatic reset overload protection and are life time lubricated. The motor shall be vented and mounted in the air stream to provide maximum cooling of the motor.

HIGH AND LOW HEAT RANGES: All units will be supplied as standard with a switch for selecting full heat at high fan speed or reduced heat at low fan speed (On 480 & 600 Volt units the switch changes the heat but not the fan speed).

OVER CURRENT PROTECTION: Circuit breakers shall be provided for branch circuit protection where required by NEC. Circuit breakers are optional on all other heaters.

TEMPERATURE CONTROL: Integral factory installed thermostat shall be tamper resistant, linear capillary type. Optional setback thermostat available.

Mounting Configurations

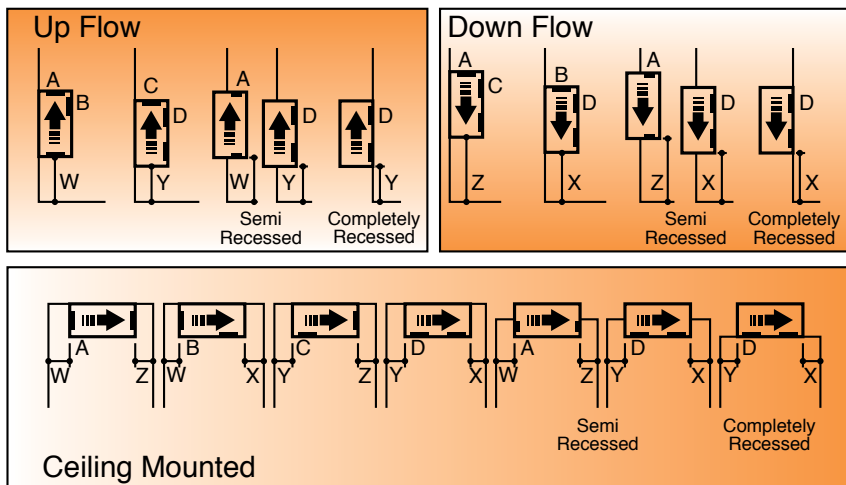

KEY: W = 6" minimum, X = 12" minimum, Y = 0" or greater, Z = 24" minimum

NOTE: Semi-recessed units are to be recessed at a maximum of 3 1/2" unless grill configuration is front in and front out.

MOUNTING CLEARANCES: Proper clearances are indicated for each mounting configuration on all positions. Minimum clearance from side of unit to the wall is zero inches. Mounting inches are provided in the back of the cabinet, accessible through the blower compartment, if necessary, remove blower deck if additional mounting screws or bolts are desired. Blower deck may be slipped forward by loosening four screws at the front to provide access to mounting holes.

6300 Series Multiple Angle Cabinet Unit Heater

Product Features (2-24 KW; All Voltages)

- For commercial and institutional application such as stores, schools, offices, transportation terminals, churches, or entrance ways
- Wall or ceiling mount; surface, semi-recessed or fully recessed
- (8) air inlet and outlet configurations
- Capacities from 2-24 kW with 230 to 1,000 CFM
- Motors are two speed, shaded pole, resilient mounted, direct drive. High/low heat and blower speed offer versatility
- ETL Listed
- Beige powder coated finish
- Choice of five standard control options include unit mounted 120 or 24V thermostats, with built-in control transformers, setback thermostat option
- Industrial type finned tubular elements
- Easily removable fan and element decks for simplified maintenance
- Full length thermal protection
- Limited warranty-one year
- Optional locking front cover

Product Dimensions

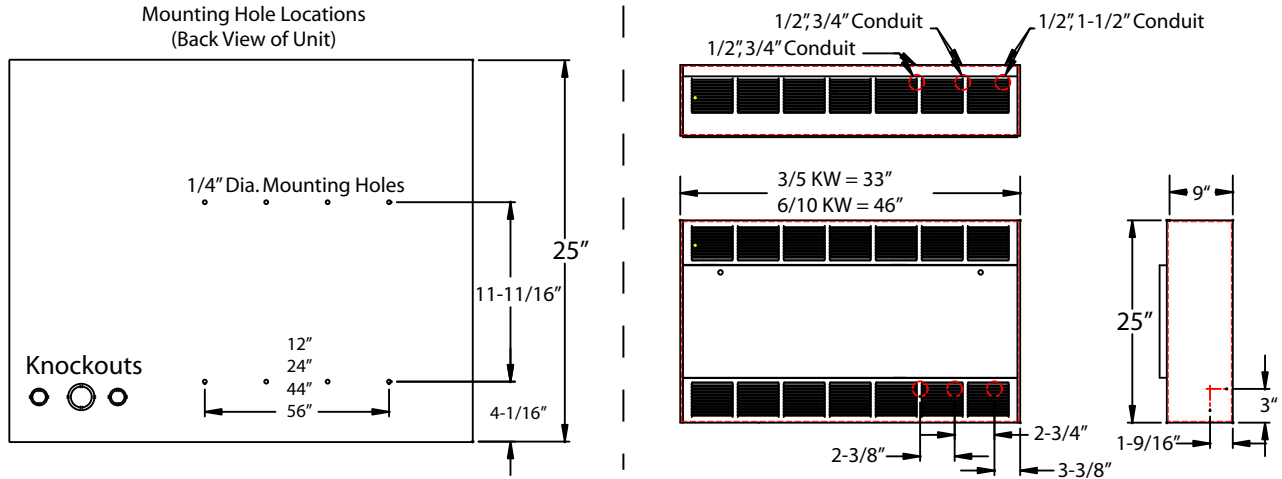

Stocked Models & Features

HEATER LENGTH	MFG CATALOG NUMBER	MFG MODEL NUMBER	HIGH				LOW				VOLTS	PHASE	WT. (LBS)	LIST
			KW	BTUs	AMPS	CFM	KW	BTUs	AMPS	CFM				
33"	06671402	6333D052033B30D0F0	5	17065	17.3	250	3	10239	9.5	230	208	1-3*	99	5129
33"	06671502	6333D052433B30D0F0	5	17065	15.0	250	3	10239	8.4	230	240	1-3*	99	5129
33"	06670802	6333D054833B30D0F0	5	17065	7.8	250	3	10239	4.6	230	480	3	99	5129
46"	06671902	6346D102433B30D0F0	10	34130	33.0	500	6	20478	17.1	460	240	1-3*	130	5786
46"	06672002	6346D104833B30D0F0	10	34130	15.4	500	6	20478	8.1	460	480	3	130	5786
International Models														
33"	04736202	6333D053834B30D0F1	5	17065	7.6	250	3	10239	4.56	230	380	3 (4-Wire)	99	5129
	04736302	6333D054134B30D0F1			6.97				4.18		415			
46"	04736402	6346D103834B30D0F1	10	34130	15.2	500	6	20478	9.12	460	380		130	5786
	04736502	6346D104134B30D0F1			13.94				8.36		415			

- Disconnect switch, dust filter, & high low operation.
- Built-in thermostat and field convertible for remote thermostat.

Accessories

MFG CATALOG NUMBER	MFG MODEL NUMBER	SIZE	DESCRIPTION	LIST	MFG CATALOG NUMBER	MFG MODEL NUMBER	SIZE	LIST
DUCT COLLAR					Fresh Air Make-Up Intake Flange & Kickbase			
04415602	DC-33	33"	The same model is used for the inlet or outlet. If duct collars are required for both inlet & outlet then 2 must be ordered.	302	07715802	FAM33	33"	598
04415702	DC-46	46"		368	07715902	FAM46	46"	686
04415802	DC-66	66"		460	07716002	FAM66	66"	1055
04415902	DC-79	79"		559	07716102	FAM79	79"	1161
RECESSING TRIM FRAMES					Kickbase (Pedestal) ONLY			
04537802	TF-33	33"	Recessing Trim Frames should be ordered to "trim-out" any recessed or semi-recessed installation.	275	07715402	KB33	33"	240
04537902	TF-46	46"		307	07715502	KB46	46"	251
04538002	TF-66	66"		384	07715602	KB66	66"	305
04538102	TF-79	79"		420	07715702	KB79	79"	333

6300 Series Multiple Angle Cabinet Unit Heater

Locking Cover Option

SD Setback Thermostat Option



6300 SD Series Features

- Multi-stage operation-only using the heat you need, when you need it
- 65 second delay between stages
- Sensor has a 94°F degree angular range and a 16' linear range
- 50-90 degree thermostat range
- Setback capability up to 12 degrees - field set. Achieves energy savings when area not occupied and heat not needed
- Purge cycle of 90 seconds allows residual heat to be exhausted from heater
- Factory pre-programmed for system type/voltage
- Easy steps to set thermostat and setback feature
- Occupancy sensor defaults to economy mode after one hour, up to 12 degree setback
- Sensor has a 94°F degree angular range and a 16' linear range

⚠ WARNING: This product can expose you to chemicals including nickel which is known to the State of California to cause cancer, and chromium, which is known to the State of California to cause birth defects and/or reproductive harm. For more information go to www.P65Warnings.ca.gov.

LENGTH	KW		Elements per Heat Deck		CFM		1-PHASE UNITS - AMPS (HIGH)				3-PHASE UNITS - AMPS (HIGH)			LIST	
	High	Low	Left	Right	High	Low	208V	240V	277V	600V	208V	240V	480V		600V
							3-WIRE								
33"	2	1	2		250	230	10.6	9.3	8.12	3.8	9.2	8.1	4.1	3.3	4153
	3	2	3				15.4	13.5	11.7	5.5	9.2	8.1	4.1	3.4	4277
	4	2	4				20.2	16.7	15.3	7.2	13.4	11.8	6	6.22	4446
	5	3	5				25	21.8	19	8	17.6	15.4	7.8	5.5	4647
	6	3	6				29.9	26	22.6	10.5	17.6	15.4	7.8	6.3	4849
46"	4	2	2		500	460	21.1	18.6	16	7.46	18.7	16.2	8.1	6.5	4732
	6	4	3				30.8	26.9	23.1	10.79	18.4	16.2	8.1	6.5	4943
	8	4	4				40.4	35.2	30.5	14.12	26.7	23.4	11.7	9.4	5173
	10	6	5				50	43.6	37.7	17.5	35.1	30.7	15.4	12.3	5381
	12	6	6				59.6	51.9	44.9	20.8	35.1	30.7	15.4	12.3	5491
66"	6	3	2	2	750	690	31.8	27.9	24.1	11.3	27.6	24.3	12.3	9.8	6017
	9	6	3	3			46.2	40.4	35	16.3	27.6	24.3	12.3	9.9	6262
	12	6	4	4			60.6	52.9	45.8	21.3	40.1	35.2	17.7	15.6	6505
	15	9	5	5			75	65.4	56.7	25.5	52.6	46.1	23.1	15.7	6731
	18	9	6	6			89.4	77.9	67.5	31.3	52.6	46.1	23.1	18.5	6974
79"	8	4	2	2	1000	920	42.3	37.1	32	14.9	36.7	32.3	16.2	13	6731
	12	8	3	3			61.5	53.8	46.5	21.6	36.7	32.3	16.2	13	6878
	16	8	4	4			80.7	70.5	61	28.2	53.4	46.8	23.5	18.8	7140
	20	12	5	5			NA	87.1	75.4	34.9	70.1	61.4	30.7	24.6	7254
	24	12	6	6			NA	NA	89.8	41.6	70.1	61.4	30.7	24.6	7387

Notes: Amps include motor Amp loads; Please see Draft Barrier Heaters - General Product Information page for custom color availability - add 10% to net heater cost; Products listed in this section are custom built and subject to 100% cancellation/restocking charges.

6300 Series Multiple Angle Cabinet Unit Heater

Custom Specified Models

HOW TO DESIGNATE A MODEL:

63	46	D	08	24	1	2	B3	S	D	O	F
Series Number	Cabinet Size 33=33" 46=46" 66=66" 79=79"	Air Flow Configuration A = Bottom in / Top out B = Bottom in / Front out C = Front in / Top out D = Front in / Front out	Element KW 2KW through 24KW See model chart for length and KW options.	Element Voltage 20 = 208V 24 = 240V 27 = 277V 41 = 415V 48 = 480V 57 = 600V	Phase 1 = Single Phase 3 = Three Phase	Number of Wires in Electrical Service 2 or 3	Control Options B3, B4, B5, B6 SD - Setback (see control options chart)	Summer Fan Switch S = Included O = Not Included	Disconnect Option C = Circuit Breaker D = Disconnect Switch O = None	Motor Fusing Option M = Required O = Not Required	Disposable Filter Option F = Required O = Not Required L - Locking Front Cover
Step 1	Step 2	Step 3	Step 4	Step 5	Step 6	Step 7	Step 8	Step 9	Step 10	Step 11	Step 12

Control Option (Step 8 on Model Designator)

SUFFIX	DESCRIPTION	LIST
B3	In-Built 1-Stage Stat and Relays which are operated by an internal 24 Volt source. (40 °F-110 °F)	135
B4*	In-Built 1-Stage Stat and Relays which are operated by an internal 120 Volt source. (40 °F-110 °F)	549
B5	In-Built 2-Stage Stat & Relays which are operated by an internal 24 Volt source. (40 °F-120 °F)	135
B6*	In-Built 2-Stage Stat and Relays which are operated by an internal 120 Volt source. (40 °F-120 °F)	549
SD	Setback Thermostat	1083

*Motor fusing included for units with 120V internal or external control source.

Disconnect Option "C" Circuit Breaker (Step 10 on Model Designator)

KW	SINGLE PHASE				THREE PHASE			
	208V	240V	277V	600V	208V	240V	480V	600V
2	378	378	478	1402	636	626	1299	1402
3	378	378	478	1402	636	626	1299	1402
4	378	378	478	1402	636	626	1299	1402
5	378	378	478	1402	636	626	1299	1402
6	378	378	478	1402	636	626	1299	1402
8	378	378	478	1402	636	626	1299	1402
10	751	751	478	1402	751	751	1299	1402
12	751	751	478	1402	751	751	1299	1402
15	751	751	751	1402	1259	903	1299	1402
16	751	751	751	1402	1259	903	1299	1402
18	751	751	751	1402	1259	903	1299	1402
20	N/A	751	751	1402	1259	1078	1299	1402
24	N/A	N/A	751	1402	1259	1078	1299	1402

Circuit breakers shown in shaded areas are required by NEC because unit exceeds 48 Amps, all others listed are optional unless otherwise stated.

Disconnect Option "D" Disconnect Switch (Step 10 on Model Designator)

KW	SINGLE PHASE				THREE PHASE			
	208V	240V	277V	600V	208V	240V	480V	600V
2	293	293	293	375	375	375	361	375
3	293	293	293	375	375	375	361	375
4	293	293	293	375	375	375	361	375
5	293	293	293	375	375	375	361	375
6	361	293	293	375	375	375	361	375
8	405	361	361	375	375	375	361	375
10	N/A	471	361	375	423	375	361	375
12	N/A	N/A	471	375	423	427	361	375
15	N/A	N/A	N/A	375	N/A	427	361	375
16	N/A	N/A	N/A	375	N/A	585	361	375
18	N/A	N/A	N/A	375	N/A	585	361	375
20	N/A	N/A	N/A	375	N/A	N/A	471	375
24	N/A	N/A	N/A	375	N/A	N/A	471	375

Disconnect option is not available on heaters with circuit breakers.

Fan Switch & Motor Fusing (Steps 9 & 11 on Model Designator)

SUFFIX	DESCRIPTION	ADDER
S	Summer Fan Switch	84
M	Motor Fusing (when not provided by control option)	155

Filter Option (Step 12 on Model Designator)

SUFFIX	SIZE	Qty.REQ'D	FILTER TYPE	LIST
F	33"	1	Replaceable	41
	46"	1		47
	66"	2		82
	79"	2		91
W	33"	1	Washable	102
	46"	1		103
	66"	2		203
	79"	2		205
L	Locking Cover			126

8500 Series Commercial Slope Top Wall Convectors



Features

- Front In/Top Out or Bottom In/Top Out air pattern
- 16 gauge steel housing powder coated with beige finish
- Tubular pre-wired wireway with 40 Amp capacity
- Connection boxes for right or left hand wiring with combination 1/2" - 3/4" knockouts at back and bottom
- Stainless steel element with Aluminum fins
- Linear limit type thermal overload with automatic reset
- Limited by max amp draw of 25 Amps (with no controls)
- Made in U.S.A.

HOW TO DESIGNATE A MODEL:

85	2	5	125	H	B	DST1
Series Number	Cabinet Size 3=20"H x 5"D 2=14"H x 5"D 1=10"H x 3"D	Unit Length (feet) 2, 3, 4, 5, 6, 7, 8, 9, 0 (enter 0 for 10')	Watts per Foot 8530=750 max 8520=500 max 8510=250 max	Voltage H=240V G = 277V F = 208V E = 120V	Air Flow F=Front in B=Bottom in	Factory Installed Options blank=none T1 or T2=Thermostat R1, R2, or R9=Relay DS=Disconnect (see control option chart)
Step 1	Step 2	Step 3	Step 4	Step 5	Step 6	Step 7

- Pencil proof louver design
- Custom colors available, consult factory

Note: Not for residential applications

Note: Disconnect limits amperage to 16 Amps



WARNING: This product can expose you to chemicals including nickel which is known to the State of California to cause cancer, and chromium, which is known to the State of California to cause birth defects and/or reproductive harm. For more information go to www.P65Warnings.ca.gov.

Product Specifications

CABINET:

Rugged 16 gauge front cover with discharge louvers in sloped top design. Pencil proof louver design for sloped outlet and front inlet grill. The finish shall be durable powder coated paint. Air flow available as bottom in - top out, or front in - top out.

ELEMENT:

All steel high mass element construction with Nickel-Chromium resistance wire embedded in compacted efficient dielectric to ensure proper heat transfer. Aluminum fins mechanically bonded to steel tube allows for increased surface area and even heat transfer.

LIMIT CONTROLS:

Automatic reset hydraulic thermal overload covers full length of heating element and shuts down heater when safe operating temperatures are exceeded.

WIRING:

Connection boxes in either end with 1/2 inch to 3/4 inch knockouts at back and bottom. Tubular pre wired wire way with 40 Amp capacity.

CONTROLS:

Optional built in tamper resistant thermostat and disconnect.

MOUNTING:

Heater shall be surface mounted to wall or mullion. Bottom inlet units must be mounted a minimum of 4 inches above finished floor front inlet.

Voltage & Wattage Specification

VOLTAGE	STANDARD WATTAGES PER FOOT	HEATER LENGTHS
120-277	100,125,150,165,187,200,250	2' through 10'

8500 Series Commercial Slope Top Wall Convectors

Standard Models

HEATER LENGTH	WATTS per FOOT	8510 SERIES		8520 SERIES		8530 SERIES	
		3" Depth x 10" Height Max watts per foot = 250		5" Depth x 14" Height Max watts per foot = 500		5" Depth x 20" Height Max watts per foot = 750	
		MFG MODEL NUMBER	LIST	MFG MODEL NUMBER	LIST	MFG MODEL NUMBER	LIST
2'	100-250	8512	861	8522	944	8532	1151
	333-750		N/A		1047		1265
3'	100-250	8513	991	8523	1090	8533	1315
	333-750		N/A		1200		1446
4'	100-250	8514	1141	8524	1258	8534	1515
	333-750		N/A		1370		1671
5'	100-250	8515	1258	8525	1380	8535	1671
	333-750		N/A		1519		1837
6'	100-250	8516	1378	8526	1512	8536	1837
	333-750		N/A		1667		2016
7'	100-250	8517	1512	8527	1665	8537	2016
	333-750		N/A		1832		2220
8'	100-250	8518	1665	8528	1832	8538	2220
	333-750		N/A		2016		2443
9'	100-250	8519	1832	8529	2016	8539	2443
	333-750		N/A		2219		2680
10'	100-250	8510	2016	8520	2219	8530	2680
	333-750		N/A		2438		2946

Note: All models qualify for international use

Note: Products listed in this section are custom built and subject to 100% cancellation/restocking charges.

*120V not available in 10' units

In-Built Control Options

SUFFIX	DESCRIPTION	LIST
T1	In-Built Tamper Proof, Single Pole, Bimetal Thermostat (0°-110°F temp. range, 25 Amp)	178
T2	In-Built Tamper Proof, Double Pole, Bimetal Thermostat (0°-110°F temp. range, 25 Amp)	228
DS	Double Pole Disconnect Switch, 16 Amp	257

Note: Due to size limitations, 8510 Series convectors can only have thermostats as In-Built options

SUFFIX	DESCRIPTION	LIST
R1	DPST Relay, 30 Amps, up to 277V, 120V coil	249
R2	SPST Relay, 18 Amps @ 277V (max), 24V coil	249
R9	24V Transformer and SPST Relay 22 Amps @ 240V, 18 Amps @ 277V (max), 24V coil (cannot be used in conjunction with T2 option)	273

Mounting/Air Flow Options

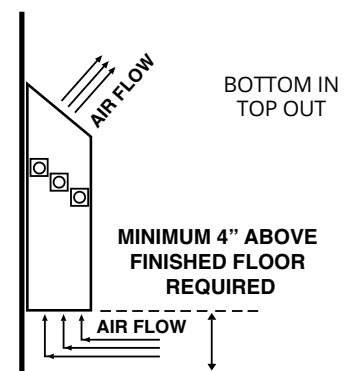
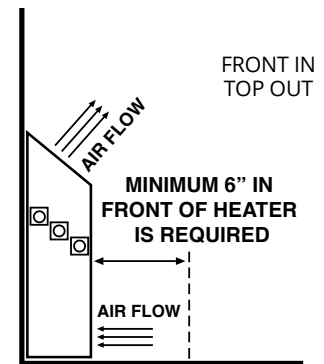

8800 Series Institutional Wall Convector



WARNING: This product can expose you to chemicals including nickel which is known to the State of California to cause cancer, and chromium, which is known to the State of California to cause birth defects and/or reproductive harm. For more information go to www.P65Warnings.ca.gov.

Features

- Single phase heaters available in all common voltages from 120V to 600V
- 11 gauge perforated steel housing powder coated with textured ivory finish
- Tamper proof left side control panel houses built-in single pole thermostat - range 40°F-110°F and disconnect switch. Thermostat on 120V-277V units is line voltage and low voltage (24V) on 346V-600V units
- Linear limit type thermal overload with automatic reset
- Tamper proof fasteners
- Stainless steel element with Aluminum fins
- Made in U.S.A.

HOW TO DESIGNATE A MODEL:

H	880	3	100
Element Voltage E=120 F=208 G=277 H=240 L=346 P=480 U=600	Series Number	Unit Length 1=18" 2=28" 3=36" 4=48" 5=60" 6=72"	Unit Wattage 050=500 075=750 100=1000 125=1250 150=1500 200=2000

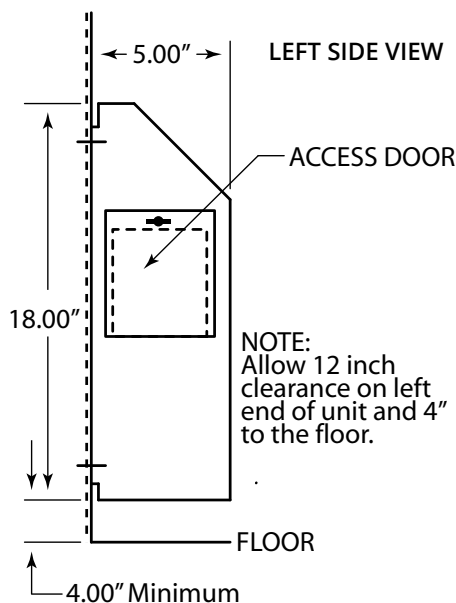

Product Specifications

CABINET:

Institutional enclosure 11 gauge perforated steel with sloped top design. Heavy duty end caps welded to the enclosure. Control compartment for housing thermostat and disconnect switch is accessible by use of security type fastener. The entire enclosure is protected by epoxy powder coated paint finish.

ELEMENT:

All steel high mass element construction with Nickel-Chromium resistance wire embedded in compacted efficient dielectric to ensure proper heat transfer. Aluminum fins mechanically bonded to steel tube allows for increased surface area and even heat transfer.

LIMIT CONTROLS:

Automatic reset hydraulic thermal overload covers full length of heating element and shuts down heater when safe operating temperatures are exceeded.

WIRING:

Wiring connections shall be made in left end of cabinet enclosure. Wiring must enter into control enclosure behind perforated steel grill.

CONTROLS:

All controls are accessible only through control enclosure door. Security type fasteners restrict access to controls. Built in thermostat and disconnect switch with manual adjustment are located in control enclosure.

Optional In-Built Controls

SUFFIX	DESCRIPTION	LIST
T2	Tamperproof, Hydraulic, Double pole In-Built thermostat range 40°-110°F, 25 Amp	228
24V*	24 Volt In-Built single pole thermostat for 120V 208V, 240V & 277V models. 40°-110°F	280

*Not available on international models

8800 Series Institutional Wall Convactor

Standard Models

MFG CATALOG NUMBER	MFG MODEL NUMBER	WATTS	BTUs	VOLTS	AMPS	LENGTH (IN.)	LIST
08990002	E8801050	500	1706	120	4.167	18	3891
08990602	F8801050			208	2.404		
08991202	H8801050			240	2.083		
08991802	G8801050			277	1.805		
08992402	L8801050			346	1.445		
08993002	P8801050			480	1.042		
08993602	U8801050			600	0.833		
08990102	E8802075	750	2560	120	6.25	28	4431
08990702	F8802075			208	3.606		
08991302	H8802075			240	3.125		
08991902	G8802075			277	2.708		
08992502	L8802075			346	2.168		
08993102	P8802075			480	1.563		
08993702	U8802075			600	1.25		
08990202	E8803100	1000	3413	120	8.333	36	4954
08990802	F8803100			208	4.808		
08991402	H8803100			240	4.167		
08992002	G8803100			277	3.610		
08992602	L8803100			346	2.890		
08993202	P8803100			480	2.083		
08993802	U8803100			600	1.667		
08990302	E8804125	1250	4266	120	10.417	48	5567
08990902	F8804125			208	6.010		
08991502	H8804125			240	5.208		
08992102	G8804125			277	4.513		
08992702	L8804125			346	3.613		
08993302	P8804125			480	2.604		
08993902	U8804125			600	2.083		
08990402	E8805150	1500	5120	120	12.5	60	6034
08991002	F8805150			208	7.212		
08991602	H8805150			240	6.25		
08992202	G8805150			277	5.415		
08992802	L8805150			346	4.335		
08993402	P8805150			480	3.125		
08994002	U8805150			600	2.5		
08990502	E8806200	2000	6826	120	16.667	72	6701
08991102	F8806200			208	9.615		
08991702	H8806200			240	8.333		
08992302	G8806200			277	7.220		
08992902	L8806200			346	5.780		
08993502	P8806200			480	4.167		
08994102	U8806200			600	3.333		

International Models

MFG CATALOG NUMBER	MFG MODEL NUMBER	WATTS	BTUs	VOLTS	AMPS	LENGTH (IN.)	LIST
09841402	M8801050i	500	1706	220	2.3	18	3705
09841502	H8801050i	500	1706	240	2.1		3705
09841602	M8802075i	750	2560	220	3.4	28	4220
09841702	H8802075i	750	2560	240	3.1		4220
09841802	M8803100i	1000	3413	220	4.5	36	4717
09841902	H8803100i	1000	3413	240	4.2		4953
09842002	M8804125i	1250	4266	220	5.7	48	5301
09842102	H8804125i	1250	4266	240	5.2		5301
09842202	M8805150i	1500	5120	220	6.8	60	5747
09842302	H8805150i	1500	5120	240	6.3		5747
09842402	M8806200i	2000	6826	220	9.1	72	6383
09842502	H8806200i	2000	6826	240	8.3		6383

4100 Series Recessed Commercial Wall Convactor



WARNING: This product can expose you to chemicals including nickel which is known to the State of California to cause cancer, and chromium, which is known to the State of California to cause birth defects and/or reproductive harm. For more information go to www.P65Warnings.ca.gov.

Features

- Front in / Front out air pattern
- 16 gauge steel housing powder coated with textured beige finish
- Tubular pre-wired wireway with 40 Amp capacity
- Connection boxes for right or left hand wiring with combination 1/2" - 3/4" knockouts at back and bottom
- Steel heating element with steel fins
- Linear limit thermal overload with automatic reset
- Recess trim frame included
- Custom colors available, contact factory
- Made in the USA

Note: Not for residential applications

HOW TO DESIGNATE A MODEL:

M41	25	F	48	1000	T
Series Number	Cabinet Size 45=20"H x 5"D 25=11"H x 4"D	Voltage/Phase G=277V, 1 Phase J=208V, 3 Phase K=240V, 3 Phase F=208V, 1 Phase H=240V, 1 Phase	Unit Length (Inches) 24, 36, 48, 60, or 72	Total Wattage	Control Option Blank=None R, R2, or R9=Relay T or T2=Thermostat (See control option chart)

Product Specifications

CABINET:

4100 series casing shall be of square design with front inlet and outlet grills suitable for recess installation. The cabinet is fabricated from 16 gauge cold rolled steel and finished with powder coated baked enamel. Junction boxes are available for left or right wiring and connected by pre-wired 40 Amp capacity wireway.

ELEMENT:

All steel high mass element construction with Nickel-Chromium resistance wire embedded in compacted efficient dielectric to ensure proper heat transfer. Aluminum fins mechanically bonded to steel tube allows for increased surface area and even heat transfer.

LIMIT CONTROLS:

Automatic reset hydraulic thermal overload covers full length of heating element and shuts down heater when safe operating temperatures are exceeded.

WIRING:

Wiring connections shall be made in left end of cabinet enclosure. Wiring must enter into control enclosure behind perforated steel grill.

CONTROLS:

All controls are accessible only through control enclosure door. Security type fasteners restrict access to controls. Built in thermostat with manual adjustment are located in control enclosure.

4100 Series Recessed Commercial Wall Convactor

M4125 Dimensions - Cabinet Sizes 4" Deep x 11" High

LENGTH (IN.)	WT. (LBS)	WATTS per FOOT AVAILABLE	VOLTS AVAILABLE	PH	LIST
24	20	187 250 333	208 240 277	1	1184
36	33				1368
48	39				1585
60	49				1801
72	56				2001

M4145 Dimensions - Cabinet Sizes 5" Deep x 20" High

LENGTH (IN.)	WT. (LBS)	WATTS per FOOT AVAILABLE	VOLTS AVAILABLE	PH	LIST	LENGTH (IN.)	WT. (LBS)	WATTS per FOOT AVAILABLE	VOLTS AVAILABLE	PH	LIST
24	45	187 250 333	208 240 277	1	1184	24	49	750	208 240 277	1	1459
36	53				1551	36	60				1791
48	63				1880	48	71				2182
60	77				2285	60	87				2657
72	92				2746	72	106				3198
24	47	500 666	208 240 277	1	1297	24	49	500 666 750	208 240	3	1459
36	57				1663	36	60				1791
48	67				2032	48	71				2182
60	82				2461	60	87				2657
72	100				2990	72	106				3203

Note: Please see page 49 for custom color availability - add 10% to net heater cost.

Note: Products listed in this section are custom built and subject to 100% cancellation/restocking charges

In-Built Control Options for Single Phase Units

SUFFIX	DESCRIPTION	LIST
T	In-Built Tamper Proof, Single Pole, Hydraulic Thermostat - 40°-110°F temp. range, 25 Amps	183
T2	In-Built Tamper Proof, Double Pole, Hydraulic Thermostat - 40°-110°F temp. range, 25 Amps	225
R	DPST Relay, 30 Amps, up to 277V, 120V coil	240
R2	SPST Relay, 18 Amps @ 277V (max), 24V coil	254
R9*	24V Transformer and SPST Relay, 22 Amps @24V, 18 Amps @ 277V (max), 24V coil	300

Note: No In-Built control options for 3 phase models

Note: Control section required when R9 is ordered. *

12" Control Section

UNIT LENGTH	MFG MODEL 4125	LIST	MFG MODEL 4145	LIST
12"	MSE4120-12	137	MSE4140-12	228

Note: 12 in. added to length of heater

Solid Back Panel

UNIT LENGTH	MFG MODEL 4125	LIST	MFG MODEL 4145	LIST
24"	MS4122	112	MS4142	181
36"	MS4123	146	MS4143	199
48"	MS4124	191	MS4144	302
60"	MS4125	231	MS4145	373
72"	MS4126	268	MS4146	416

3000 Series Fan Forced Ceiling Heater



Standard Models

WHITE		SELECTABLE INSTALLATION WATTAGE	MAX BTUs	VOLTS	MAX AMPS	LIST
MFG CATALOG NUMBER	MFG MODEL NUMBER					
09488202	E3035DWBW	750 or 1500	5120	120	13	428
09488302	E3038DWBW	900 or 1800	6143	120	15	
09488802	H3032DWBW	750 or 1000 - 1500 or 2000	6826	208 / 240	8	
09489002	G3032DWBW	2000	6826	277	7	

- Wattage selectable at time of installation - models shipped wired to highest wattage
- Fan purge circuit (has 2 wire control circuit for use with remote wall thermostat)
- Models may not be used with remote double pole thermostat
- Drywall depth embossments on back can
- Powder coated 18 gauge steel front
- Manual reset thermal limit
- Steel block fin element
- Disconnect included
- Propeller style fan blade - 1060 RPM / 100 CFM
- Weight 6 lbs.
- Optional field installed control voltage relays available
- Rough in dimensions - 9 1/4" Wide - 12 1/8" High - 3 5/8" Deep
- Grill dimensions: 9 25/32" Wide - 13" High
- Made in U.S.A.

Field Installed Accessories

MFG CATALOG NUMBER	MFG MODEL NUMBER	DESCRIPTION	LIST
09968402	30R	24 VOLT RELAY	60
09968502	30R2	120 VOLT RELAY	60
09515002	30R8	208/240 VOLT RELAY	63
09514902	30R7	277 VOLT RELAY	63
09969702	303EX8RW	1" EXTENDER	71
09969602	303EX16RW	2" EXTENDER	72
09969502	303EX32RW	4" SURFACE MOUNT FRAME	82
04600302	TB3000	T-BAR FRAME	100

WARNING: This product can expose you to chemicals including nickel which is known to the State of California to cause cancer, and chromium, which is known to the State of California to cause birth defects and/or reproductive harm. For more information go to www.P65Warnings.ca.gov.

3380 Series Commercial Fan Forced Ceiling Heater



WARNING: This product can expose you to chemicals including nickel which is known to the State of California to cause cancer, and chromium, which is known to the State of California to cause birth defects and/or reproductive harm. For more information go to www.P65Warnings.ca.gov.

Product Specifications

The heaters are to be constructed of a heavy gauge steel housing. The finish shall be baked-on powder coat in Ceiling White color. The units shall be available in ratings from 1500 through 4800 Watts with an optional factory installed single pole thermostat.

The heaters have a low speed 600-RPM motor, which drives a vane axial blower to deliver a quite 175 CFM's of down flow air. The heating element shall be of the block finned type with large, parallel steel fins for quick heat transfer. Unit shall have as standard, a manual reset capillary type limit control, for added safety. Unit weight 22 pounds.

Features & Standard Models

Recess, Surface, or "T" Bar Mounting

- Fan purge circuit (has 2 wire control circuit for use with remote wall thermostat)
- Disconnect switch
- White powder coated 18-gauge steel grill
- Manual reset thermal limit
- Steel block fin element
- Vane axial fan blade: 1.5KW - 4.0KW units: 700 RPM motor; 175 CFM 4.8KW units: 900 RPM motor; 200 CFM
- Rough in dimensions: 14 1/8" wide x 19 1/2" high x 4" deep
- Grill dimensions: 16 3/16" wide x 21" high
- Optional factory installed tamper resistant thermostat
- Made in U.S.A.

MFG CATALOG NUMBER	MFG MODEL NUMBER	KW	BTUs	VOLTS	PH	AMPS	TEMP RISE	LIST	
03664802	E3383D-RP	1.5	5120	120	1	12.5	27 °F	975	
03662902	F3386D-RP	4.0	13600	208		19.2	72 °F	1023	
03663002	F3387D-RP	4.8	16382	208		23.1	76 °F	1153	
03663402	HF3384D-RP	2.0 / 1.5	6826/5120	240/208		8.3/7.2	36 °F	897	
03663502	HF3385D-RP	3.0 / 2.3	10200/7679	240/208		12.5/10.8	54 °F	1023	
03663602	HF3386D-RP	4.0 / 3.0	13600/10200	240/208		16.8/14.4	72 °F	1023	
03663702	H3387D-RP	4.8	16382	240		20	76 °F	1153	
03665002	G3383D-RP	1.5	5120	277		5.4	27 °F	975	
03664102	G3384D-RP	2.0	6826	277		7.2	36 °F	1023	
03664202	G3385D-RP	3.0	10200	277		10.8	54 °F	1154	
03664302	G3386D-RP	4.0	13600	277		14.4	72 °F	1154	
03664402	G3387D-RP	4.8	16382	277		17.3	76 °F	1277	
International Models									
04708802	M3384D-RPi	1680	5734	220		1	7.6	30 °F	984
04708902	M3385D-RPi	2520	8600		11.5		50 °F	1034	
04709002	M3386D-RPi	4032	13761		18.3		72 °F	1163	

Accessories

MFG CATALOG NUMBER	MFG MODEL NUMBER	DESCRIPTION	WT. (LBS)	LIST
03778502	BOX3310	Additional Back Can	10	164
03811002	3380EX33	Surface Mounting Adapter	5	147
04600202	TB3380	2X2 T-Bar Mounting Kit	7	100
Thermostat- Add suffix T to model		Factory installed single pole. Range-40° F-110° F		180

3480 Series Commercial Fan Forced Recessed Mounted Ceiling Heater

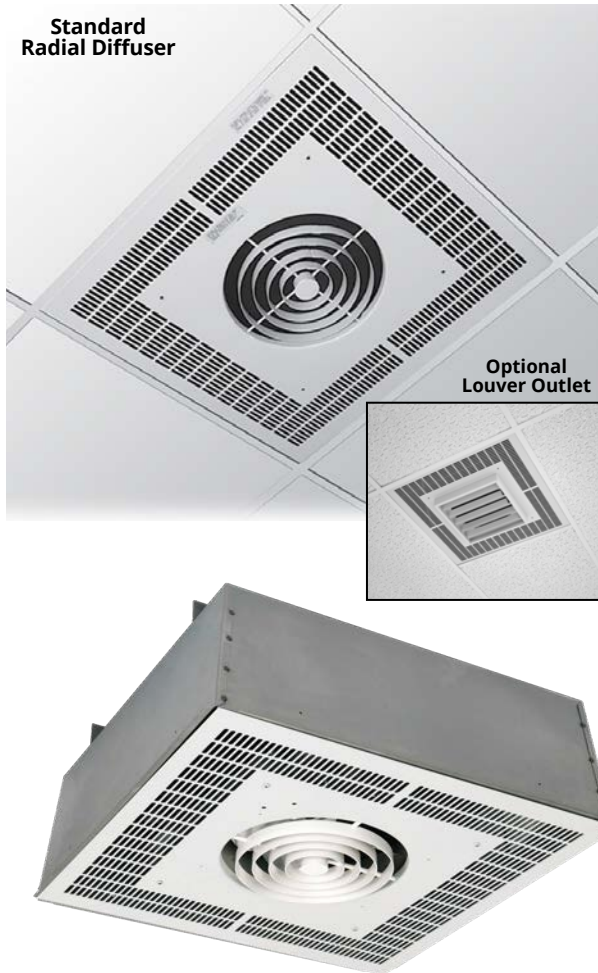

Features

- White powder coated 20 gauge grill
- All units have manual reset thermal limit, 24V control transformer, and 24V relay (A1 suffix)
- Enclosed steel fin sheath element
- Rough in dimensions: 23 $\frac{1}{16}$ " sq. x 9 $\frac{1}{8}$ " deep
- Maximum mounting is 12'
- Made in U.S.A.



WARNING: This product can expose you to chemicals including nickel which is known to the State of California to cause cancer, and chromium, which is known to the State of California to cause birth defects and/or reproductive harm. For more information go to www.P65Warnings.ca.gov.

Notes

- Optional controls must be factory installed.
- Field installation is not acceptable and violates ETL listing and factory warranty.
- Degrees F air rise is measured at 1,000 F.P.M. and 600 CFM
- Throw designed for 8 to 12 foot ceilings. dB = 63.9
- Unit Weight: 45 lbs. | Low Voltage: UT1001
- Recommended remote thermostats: Low voltage - UT1001
- Maximum mounting is 12' AFF

Product Specifications

Contractor shall supply and install heavy duty ceiling mounted forced air electric heater(s) of the wattage, voltage and phase as indicated on the plans. The heater shall be so designed to provide an even distribution of heated air to the space to be heated by drawing return air in the periphery of the heater, across and through the element and be discharged from the center section of the heater by means of an electric motor and axial flow fan blade.

Heaters shall be recessed type and mounted flush with the finished ceiling. The return grille assembly shall be constructed of a one piece heavy gauge steel with $\frac{1}{4}$ " slots for return air and concentric rings for uniform air discharge. Grille assembly shall be attached to chassis by tamper-resistant (allen head) machine screws. All parts of enclosure shall be heavy gauge steel, zinc coated both sides and finished in neutral off white powder coat paint.

Enclosure shall be constructed of $\frac{1}{6}$ " x $\frac{3}{8}$ " rounded edge horizontal steel louvers which shall be spaced for maximum opening of $\frac{5}{16}$ ". Louvers shall be welded at every intersection to evenly spaced $\frac{1}{8}$ " diameter vertical members. Discharge grille to have concentric rings for uniform air discharge. Grille assembly shall be attached to chassis by tamper-resistant (allen head) machine screws. All part of enclosure shall be heavy gauge steel, Zinc coated both sides and finished in neutral off white colored powder coat finish.

Motor shall be permanently lubricated, unit bearing, totally enclosed, with impedance protection. Motors shall operate at no more than 1300 RPM and shall be same voltage as the heater.

Heaters shall have a rating of 600 CFM at 1,000 F.P.M. with a maximum temperature rise of 44°F and 63.9 dB sound level.

Element assemblies shall consist of two or three corrosion resistant steel sheathed type elements mechanically bonded to common corrosion resistant steel fins. Each sheathed element shall consist of helically coiled Nickel Chromium alloy resistant wire completely embedded in and surrounded by magnesium oxide, enclosed and wedged into corrosion resistant steel sheaths. Elements shall have 2" cold conductor pins extending into sheath and shall have a density of no more than 60 Watts per inch.

Heaters shall be equipped with a "manual reset" thermal overload which disconnects elements and motor in the event normal operating temperatures are exceeded. For safety, if opened due to abnormal temperature, thermal overload shall remain open until manually reset. Automatic reset thermal overloads which allow the element to continue to cycle under abnormal conditions will not be accepted. Heaters shall be ETL listed.

3480 Series Commercial Fan Forced Recessed Mounted Ceiling Heater

Standard Models

MFG CATALOG NUMBER	MFG MODEL NUMBER	KW	BTUs	VOLTS	PH	AMPS	TEMP RISE	LIST	
03153302	F3482A1	2	6826	208	1	9.6	15 °F	2208	
03152602	H3482A1			240		8.3		2208	
03149702	G3482A1			277		7.2		2208	
03184702	P3482A1			480		4.2		2412	
04702802	J3482A1	2	6826	208	3	5.6	15 °F	2365	
03984902	K3482A1			240		4.8		2365	
04702402	Y3482A1			480		2.4		2574	
03153202	F3483A1			208		14.4		2230	
03148402	H3483A1	3	10200	240	1	12.5	22 °F	2230	
03148102	G3483A1			277		10.8		2230	
03184802	P3483A1			480		6.3		2439	
04706402	J3483A1			208		8.3		2392	
03985002	K3483A1	3	10200	240	3	7.2	22 °F	2392	
04702502	Y3483A1			480		3.6		2600	
03153602	F3484A1			208		19.2		2258	
03155402	H3484A1	4	13600	240	1	16.8	30 °F	2258	
03148002	G3484A1			277		14.4		2258	
03185002	P3484A1			480		8.3		2463	
03148702	J3484A1			208		11.1		2438	
03148202	K3484A1	4	13600	240	3	9.7	30 °F	2438	
03185802	Y3484A1			480		4.8		2644	
03154802	F3485A1			208		24.1		2531	
03155102	H3485A1	5	17000	240	1	20.8	37 °F	2531	
03149602	G3485A1			277		18.1		2531	
03185402	P3485A1			480		10.4		2750	
03150802	J3485A1			208		13.9		2687	
03180902	K3485A1	5	17000	240	3	12.1	37 °F	2687	
03184002	Y3485A1			480		6.1		2901	
03661002	PT3480	Recess Frame - Weight 5 lbs.							256
International Models									
0470971	M3482T2i	2	6826	220	1	9.1	15 °F	2120	
0470988	N3482T2i			240		8.3			
0470995	M3483T2i	3	10200	220	1	13.6	22 °F	2144	
0471008	N3483T2i			240		12.5			
0471015	M3484T2i	4	13600	220	1	18.2	30 °F	2171	
0471022	N3484T2i			240		16.7			

*Optional Louver Outlet - \$125 Adder

Factory Installed Control Sections

SUFFIX	DESCRIPTION	LIST
S	Disconnect Switch	254
T	Thermostat (0° - 110°F)	153
RELAYS FOR FIELD SUPPLIED CONTROL - NIGHTLY SETBACK		
R*	Relay Control Voltage Same as Heater (control voltage field supplied)	125
R1	Relay 24V Control Voltage (control voltage field supplied)	207
R2	Relay 120V Control Voltage (control voltage field supplied)	189

Note: When relay for the field is supplied, night setback is built into the heater. The A1 option is replaced by this relay to be controlled by building supplied voltage to the relay.
* 208/240 volt models only

Product Dimensions

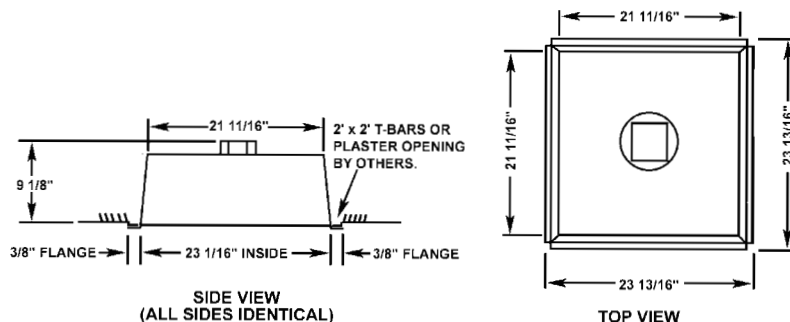

3470 Series Commercial Fan Forced Surface Mounted Ceiling Heater

Product Specifications

CONSTRUCTION:

Made in U.S.A.
Contractor shall supply and install heavy duty ceiling mounted forced air electric heater(s) of the wattage, voltage and phase as indicated on the plans. The heater shall so be designed to provide an even distribution of heated air to the space to be heated by drawing return air in the periphery of the heater, across and through the element and be discharged from the center section of the heater by mean of an electric motor and axial flow fan blade.

MOTOR: Motor shall be permanently lubricated, unit bearing, totally enclosed shaded pole type with impedance protection. Motors shall operate at no more than 1300 RPM and shall be same voltage as the heater.

PERFORMANCE: Heaters shall have a rating of 600 CFM at 1,000 F.P.M. with a maximum temperature rise of 44°F and 63.9 dB rating.

ELEMENT: Element assemblies shall consist of two or three corrosion resistant steel sheathed type elements mechanically bonded to common corrosion resistant steel fins. Each sheathed element shall consist of helically coiled Nickel Chromium alloy resistant wire completely embedded in and surrounded by Magnesium Oxide, enclosed and wedged into corrosion resistant steel sheaths. Elements shall have 2" cold conductor pins extending into sheath and shall have a density of no more than 60 watts per inch.

THERMAL OVERLOAD: Heaters shall be equipped with a "manual reset" thermal overload which disconnects elements and motor in the event normal operating temperatures are exceeded. For safety, if opened due to abnormal temperature, thermal overload shall remain open until manually reset. Automatic reset thermal overloads which allow the element to continue to cycle under abnormal conditions will not be accepted.

COMMERCIAL AND INSTITUTIONAL APPLICATIONS: Use in - vestibules, entrance ways, lobbies, rest rooms and small office and guard building applications.



WARNING: This product can expose you to chemicals including nickel which is known to the State of California to cause cancer, and chromium, which is known to the State of California to cause birth defects and/or reproductive harm. For more information go to www.P65Warnings.ca.gov.



***Optional Louver Diffuser**

Product Dimensions

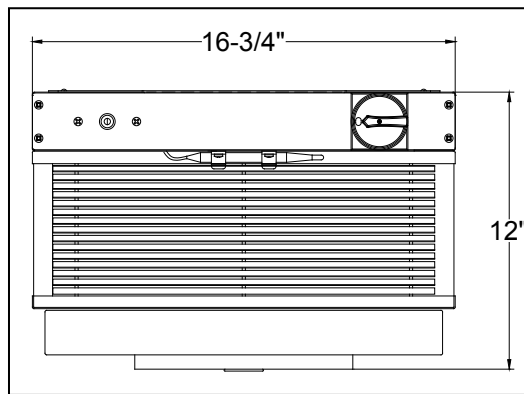

Standard Models

MFG CATALOG NUMBER	MFG MODEL NUMBER	KW	BTUS	VOLTS	PH	AMPS	TEMP RISE	LIST
03982602	F3472A1	2	6826	208	1	9.6	15 °F	2208
03982702	H3472A1			240		8.3	15 °F	2208
03982802	G3472A1			277		7.2	15 °F	2208
03243302	P3472A1			480		4.2	15 °F	2412
03983702	J3472A1	2	6826	208	3	5.6	15 °F	2365
03983802	K3472A1			240		4.8	15 °F	2365
04702202	Y3472A1			480		2.4	15 °F	2574
03810602	F3473A1			208		14.4	22 °F	2230
03982902	H3473A1	3	10200	240	1	12.5	22 °F	2230
03983002	G3473A1			277		10.8	22 °F	2230
03243402	P3473A1			480		6.3	22 °F	2439
03983902	J3473A1			208		8.3	22 °F	2418
03984002	K3473A1	3	10200	240	3	7.2	22 °F	2418
04702302	Y3473A1			480		3.6	22 °F	2622
03983102	F3474A1			208		19.2	30 °F	2258
03983202	H3474A1			240		16.8	30 °F	2258
03983302	G3474A1	4	13600	277	1	14.4	30 °F	2258
03243502	P3474A1			480		8.3	30 °F	2463
03984102	J3474A1			208		11.1	30 °F	2438
03984202	K3474A1			240		9.7	30 °F	2438
03243602	Y3474A1	5	17000	480	3	4.8	30 °F	2644
03983402	F3475A1			208		24.1	37 °F	2531
03983502	H3475A1			240		20.8	37 °F	2531
03983602	G3475A1			277		18.1	37 °F	2531
03243702	P3475A1	5	17000	480	1	10.4	37 °F	2750
03984302	J3475A1			208		13.9	37 °F	2687
03984402	K3475A1			240		12.1	37 °F	2687
03243802	Y3475A1			480		6.1	37 °F	2901
International Models								
04709102	M3472T2i	2	6826	220	1	9.1	15 °F	2120
04709202	N3472T2i			240		8.3	15 °F	2120
04709302	M3473T2i	3	10200	220	1	13.6	22 °F	2171
04709402	N3473T2i			240		12.5	22 °F	2171
04709502	M3474T2i	4	13600	220	1	18.2	30 °F	2171
04709602	N3474T2i			240		16.7	30 °F	2171

Notes

- Optional controls must be factory installed. (Field installation is not acceptable and violates and factory warranty)
- Degree F air rise is measured at 1,000 F.P.M. and 600 CFM. Throw designed for 8 to 12 foot ceilings
- Decibel rating 63.9
- Unit weight: 42 lbs.
- Recommended Remote Thermostats:
Low Voltage: UT1001
- Maximum mounting is 12' AFF

Factory Installed Control Sections

SUFFIX	DESCRIPTION	LIST
S	Disconnect Switch	254
T	Single Pole Thermostat (40°-110°F)	153
RELAYS FOR FIELD SUPPLIED NIGHTLY SETBACK		
R*	Relay control voltage same as heater (control voltage field supplied) *208/240 volt models only	125
R1	Relay 24V Control Voltage (control voltage field supplied)	207
R2	Relay 120V Control Voltage (control voltage field supplied)	189

Optional Adjustable Louver Diffuser - **\$125** Adder

Note: When relay for the field is supplied, night setback is built into the heater. The A1 option is replaced by this relay to be controlled by building supplied voltage to the relay.

3340 Series Heavy Duty Recessed Mounted Ceiling Heater



Features

- Dual vane axial fan blades
- Lockable disconnect switch
- Automatic purge
- Manual reset thermal limit
- Low voltage control
- Steel block fin elements
- Optional built in thermostat with 40° - 110°F range
- Heavy duty 20 gauge powder coated grille, hinged for easy access during maintenance.
- Mounts in standard 2 x 4 T-Bar ceiling grid
- Dimensions 47 1/16" L x 23 1/16" W x 6 1/4" deep
- When ordered without thermostat, terminal block included for field connection of remote low voltage single stage thermostat
- Models offered with BMS relay. (relay requires field supplied 24V source)
- Made in U.S.A.

WARNING: This product can expose you to chemicals including nickel which is known to the State of California to cause cancer, and chromium, which is known to the State of California to cause birth defects and/or reproductive harm. For more information go to www.P65Warnings.ca.gov.



Product Specifications

Furnish and install Heavy-Duty Forced Air T-Bar mounted ceiling heaters, where specified. The overall dimensions are 47 1/16" L x 23 1/16" W x 6 1/4" deep. The units shall be available in ratings of 6000,8000, & 9600 watts at 208 volt (1 or 3Ø), 240 volt (1 or 3Ø), 277 volt (1Ø), & 480 volt (3Ø). The heaters shall have (2) low-speed 600 RPM, 4-pole motors which drives vane axial blowers to deliver a quiet 350 CFM of down flow air. The two heating elements shall be of the sealed tubular type with large, parallel steel fins for quick heat transfer. Units shall have as a standard, a manual reset thermal overload cut-off for added safety, fan delay switch, and manual disconnect switch. Optional built-in tamper proof thermostat which shall be calibrated to provide a range of 40°F. to 110°F. An optional 24 volt control relay* shall be installed for control from Building Management System (BMS). Optional accessory shall include a semi-recess mounting adapter and a 16-gauge heavy duty grille. All heaters shall be listed by ETL. The heating element shall be supplied with a manufacturer's one year limited warranty.

MODEL NUMBER	CATALOG NUMBER	kW	BTU's	VOLTS	PH	CFM	LIST	MODEL NUMBER	CATALOG NUMBER	kW	BTU's	VOLTS	PH	CFM	LIST
F3346TB	04937802	6	20478	208	1	350	4200	F3346-BMSTB	04940402	6	20478	208	1	350	4200
H3346TB	04937902	6	20478	240	1	350	4200	H3346-BMSTB	04940502	6	20478	240	1	350	4200
G3346TB	04938002	6	20478	277	1	350	4200	G3346-BMSTB	04940602	6	20478	277	1	350	4200
J3346TB	04938102	6	20478	208	3	350	4200	J3346-BMSTB	04940702	6	20478	208	3	350	4200
K3346TB	04938202	6	20478	240	3	350	4200	K3346-BMSTB	04940802	6	20478	240	3	350	4200
P3346TB	04938302	6	20478	480	3	350	4200	P3346-BMSTB	04940902	6	20478	480	3	350	4200
G3348TB	04938402	8	27304	277	1	350	4600	G3348-BMSTB	04941002	8	27304	277	1	350	4600
J3348TB	04938502	8	27304	208	3	350	4600	J3348-BMSTB	04941102	8	27304	208	3	350	4600
K3348TB	04938602	8	27304	240	3	350	4600	K3348-BMSTB	04941202	8	27304	240	3	350	4600
P3348TB	04938702	8	27304	480	3	350	4600	P3348-BMSTB	04941302	8	27304	480	3	350	4600
J3349TB	04938802	9.6	32765	208	3	350	5100	J3349-BMSTB	04941402	9.6	32765	208	3	350	5100
K3349TB	04938902	9.6	32765	240	3	350	5100	K3349-BMSTB	04941502	9.6	32765	240	3	350	5100
P3349TB	04939002	9.6	32765	480	3	350	5100	P3349-BMSTB	04941602	9.6	32765	480	3	350	5100
F3346TTB	04939102	6	20478	208	1	350	4200	F3346T-BMSTB	04941702	6	20478	208	1	350	4200
H3346TTB	04939202	6	20478	240	1	350	4200	H3346T-BMSTB	04941802	6	20478	240	1	350	4200
G3346TTB	04939302	6	20478	277	1	350	4200	G3346T-BMSTB	04941902	6	20478	277	1	350	4200
J3346TTB	04939402	6	20478	208	3	350	4200	J3346T-BMSTB	04942002	6	20478	208	3	350	4200
K3346TTB	04939502	6	20478	240	3	350	4200	K3346T-BMSTB	04942102	6	20478	240	3	350	4200
P3346TTB	04939602	6	20478	480	3	350	4200	P3346T-BMSTB	04942202	6	20478	480	3	350	4200
G3348TTB	04939702	8	27304	277	1	350	4600	G3348T-BMSTB	04942302	8	27304	277	1	350	4600
J3348TTB	04939802	8	27304	208	3	350	4600	J3348T-BMSTB	04942402	8	27304	208	3	350	4600
K3348TTB	04939902	8	27304	240	3	350	4600	K3348T-BMSTB	04942502	8	27304	240	3	350	4600
P3348TTB	04940002	8	27304	480	3	350	4600	P3348T-BMSTB	04942602	8	27304	480	3	350	4600
J3349TTB	04940102	9.6	32765	208	3	350	5100	J3349T-BMSTB	04942702	9.6	32765	208	3	350	5100
K3349TTB	04940202	9.6	32765	240	3	350	5100	K3349T-BMSTB	04942802	9.6	32765	240	3	350	5100
P3349TTB	04940302	9.6	32765	480	3	350	5100	P3349T-BMSTB	04942902	9.6	32765	480	3	350	5100

CP & RCP Series Radiant Ceiling Panel Heaters

Product Description

For surface or recessed installation, radiant ceiling panels radiate energy like the solar radiation which warms us, heats objects, not the air. With no moving parts, these heating panels create gentle warmth and toasty comfort.

Radiant ceiling panels provide a low surface temperature and broad heat distribution. Clean, gentle comfortable heat that is ideal for offsetting perimeter heat loss or neutralizing downdrafts over glass. These versatile and flexible panels may be used virtually anywhere in homes, schools, hospitals, motels and a broad variety of other commercial or industrial installations.



WARNING: This product can expose you to chemicals including nickel which is known to the State of California to cause cancer, and chromium, which is known to the State of California to cause birth defects and/or reproductive harm. For more information go to www.P65Warnings.ca.gov.

Product Specifications

CONSTRUCTION:

Radiant Ceiling Panels shall be made of highest quality steel casing. Front panel shall be painted with textured powder coated finish. Electric Resistance element is fixed between dielectric material and insulation. Two inches of insulation is compressed to one inch by back panel to minimize upward heat loss and radiant efficiency. Radiant panels shall have 36" pre-wired flexible cable for easy installation and wiring connections. CP Series is 20 Gauge metal. Made in U.S.A.

INSTALLATION:

CP Series shall be designated as 2x2 or 2x4 size. All panels are 1" thick. The size shall be nominal dimension to be manufactured to fit drop ceiling systems. Standard units will fit regular "T" Bar frame. For regular or trim line or other frame sizes, special construction is required. RCP Series shall be used in recess mounting applications. RCP Series shall be 2" less in width to recess between nominal 24" center ceiling joists. RCP Series shall be complete with recess frame for finished construction.

ACCESSORIES:

Surface mounting frames shall be optional for surface mounting the CP Series, and are Aluminum mill finish. Frames can be painted white to match panel.

OPTIONS:

Silk-screening the exposed surface to match ceiling tiles is available, as well as silicone sealed metal parts for high humidity applications.

CP Series - "T" Bar & Surface Mounted

MFG CATALOG NUMBER	MFG MODEL NUMBER	WATTS	BTUs	AMPS	VOLTS	WT. (LBS)	LIST
Dimensions: 2' x 4' (Nominal) x 1"							
04587102	CP805	500	1707	2.4	208	20 lb.	683
04587202	CP125			4.2/2.1	120/240		683
04587302	CP705	750	2560	1.8	277	20 lb.	683
04587402	CP807			3.6	208		704
04587502	CP127			6.3/3.1	120/240		704
04587602	CP707			2.7	277		704
Dimensions: 2' x 2' (Nominal) x 1"							
04587702	CP802	250	853	1.2	208	13 lb.	450
04587802	CP122			2.1/1.0	120/240		450
04587902	CP702	375	1280	.9	277	13 lb.	450
04588002	CP803			1.8	208		544
04588102	CP123			3.1/1.6	120/240		544
04588202	CP703			1.4	277		544
04591002	SF400 Surface Frame for 2' x 4' Panels (CP only)					10 lb.	302
04590902	SF200 Surface Frame for 2' x 2' Panels					6 lb.	245

NOTE:

- + an additional \$952 adder for silk screening
- + \$95 adder for silicone
- + \$25.00 for each unit for application of silicone to ceiling panel for high humidity areas

RCP Series - Frame in Ceiling Mounted

MFG CATALOG NUMBER	MFG MODEL NUMBER	WATTS	BTUs	AMPS	VOLTS	WT. (LBS)	LIST
Dimensions: 2' x 4' (Including Recessing Frame)							
04588302	RCP805	500	1707	2.4	208	30 lb.	970
04588402	RCP125			4.2/2.1	120/240		970
04588502	RCP705	750	2560	1.8	277	30 lb.	970
04588602	RCP807			3.6	208		1067
04588702	RCP127			6.3/3.1	120/240		1067
04588802	RCP707			2.7	277		1067
Dimensions: 2' x 2' (Including Recessing Frame)							
04588902	RCP802	250	853	1.2	208	19 lb.	653
04589002	RCP122			2.1/1.0	120/240		653
04589102	RCP702	375	1280	.9	277	19 lb.	653
04589202	RCP803			1.8	208		815
04589302	RCP123			3.1/1.6	120/240		815
04589402	RCP703			1.4	277		815

International Models

MFG CATALOG NUMBER	MFG MODEL NUMBER	WATTS	BTUs	AMPS	VOLTS	WT. (LBS)	LIST
Dimensions: 2' x 4' (Nominal) x 1"							
04710302	CP2205i	420	1434	1.9	220	20	656
04710402	CP125i	500	1707	4.2/4.1	120/240		656
04710502	CP2207i	630	2150	2.9	220	20	677
04710602	CP127i	750	2560	6.3/3.1	120/240		677
Dimensions: 2' x 2' (Nominal) x 1"							
04710702	CP2202i	210	717	0.95		13	430
04710802	CP122i	250	853	2.1/1.0	120/240		430
04710902	CP2203i	315	1075	1.4	220	13	521
04711002	CP123i	375	1280	3.1/1.6	120/240		521
				1.4	277		521

MFG CATALOG NUMBER	MFG MODEL NUMBER	WATTS	BTUs	AMPS	VOLTS	WT. (LBS)	LIST
Dimensions: 2' x 4' (Including Recessing Frame)							
04711102	RCP2205i	420	1434	1.9	220	30	977
04711202	RCP125i	500	1707	4.2/4.1	120/240		930
04711302	RCP2207i	630	2150	2.9	220	30	1027
04711402	RCP127i	750	2560	6.3/3.1	120/240		1027
Dimensions: 2' x 2' (Including Recessing Frame)							
04711502	RCP2202i	210	717	0.95	220	19	626
04711602	RCP122i	250	853	2.1/1.0	120/240		626
04711702	RCP2203i	315	1075	1.4	220	19	784
04711802	RCP123i	375	1280	3.1/1.6	120/240		784

CVX Series Radiant Cove Ceiling Heater



Product Description

Cove Heaters have a subtly contoured concave surface with a saw-tooth profile. The concave parabolic face plate performs a two-fold function: (1) it focuses the infrared rays and (2) directs the heat downward along cold perimeters and toward the center of the room. The sawtooth surface design increases the radiating surface area by 45%, thereby increasing the comfort level of the room faster and ensuring more rapid recovery from heat losses.

Product Specifications

Furnish and install Electric Cove Heaters where specified. The heaters shall be constructed of .096" thick Aluminum. The heater surface shall be concave in contour and saw-tooth in profile. The finish shall be of powder coat white finish. The heaters shall be available in ratings from 325 through 1250 Watts, at 120, 240, 208 and 277 Volts. The heating element shall be of Nichrome wire, embedded in Magnesium Oxide powder, enclosed and sealed in Aluminum metal tubing. The heater shall be listed by ETL and the elements shall be supplied with a one year limited warranty. Made in U.S.A.

Standard Models

MFG CATALOG NUMBER	MFG MODEL NUMBER	WATTS	BTUs	AMPS	VOLTS	LENGTH	WT. (LBS)	LIST
04717102	CV3212X	325	1109	2.7	120	34"	7	296
04717202	CV32YX	325	1109	1.6	208	34"	7	296
04717302	CV32X	325	1109	1.4	240	34"	7	296
04717402	CV3227X	325	1109	1.2	277	34"	7	296
04575802	CV4512X	450	1536	3.8	120	42"	7	349
04575902	CV45X	450	1536	1.9	240	42"	7	349
04576002	CV45YX	450	1536	2.2	208	42"	7	349
04576102	CV4527X	450	1536	1.6	277	42"	7	349
04576202	CV6012X	600	2048	5.0	120	60"	10	431
04576302	CV60X	600	2048	2.5	240	60"	10	431
04576402	CV60YX	600	2048	2.9	208	60"	10	431
04576502	CV6027X	600	2048	2.2	277	60"	10	431
04576602	CV7512X	750	2560	6.3	120	72"	13	476
04576702	CV75X	750	2560	3.1	240	72"	13	476
04576802	CV75YX	750	2560	3.6	208	72"	13	476
04576902	CV7527X	750	2560	2.7	277	72"	13	476
04577002	CV9012X	900	3072	7.5	120	84"	14	537
04577102	CV90X	900	3072	3.8	240	84"	14	537
04577202	CV90YX	900	3072	4.3	208	84"	14	537
04577302	CV9027X	900	3072	3.2	277	84"	14	537
04577402	CV10012X	1000	3413	8.3	120	96"	17	561
04577502	CV100X	1000	3413	4.2	240	96"	17	561
04577602	CV100YX	1000	3413	4.8	208	96"	17	561
04577702	CV10027X	1000	3413	3.6	277	96"	17	561
04577802	CV11012X	1100	3754	9.2	120	108"	19	625
04577902	CV110X	1100	3754	4.6	240	108"	19	625
04578002	CV110YX	1100	3754	5.3	208	108"	19	625
04578102	CV11027X	1100	3754	4.0	277	108"	19	625
04578202	CV12512X	1250	4266	10.4	120	120"	21	689
04578302	CV125X	1250	4266	5.2	240	120"	21	689
04578402	CV125YX	1250	4266	6.0	208	120"	21	689
04578502	CV12527X	1250	4266	4.5	277	120"	21	689

International Models

04711902	CV4522Xi	450	1536	2.0	220	42"	7	336
04712002	CV45Xi	450	1536	1.9	240	42"	7	336
04712102	CV6022Xi	600	2048	2.7	220	60"	10	421
04712202	CV60Xi	600	2048	2.5	240	60"	10	421
04712302	CV7522Xi	750	2560	3.4	220	72"	13	462
04712402	CV75Xi	750	2560	3.1	240	72"	13	462
04712502	CV9022Xi	900	3072	4.1	220	84"	14	522
04712602	CV90Xi	900	3072	3.8	240	84"	14	522
04712702	CV10022Xi	1000	3413	4.5	220	96"	17	546
04712802	CV100Xi	1000	3413	4.2	240	96"	17	546
04712902	CV11022Xi	1100	3754	5.0	220	108"	19	605
04713002	CV110Xi	1100	3754	4.6	240	108"	19	605
04713102	CV12522Xi	1250	4266	5.7	220	120"	21	669
04713202	CV125Xi	1250	4266	5.2	240	120"	21	669

Accessories & Dimensions

MFG CATALOG NUMBER	MFG MODEL NUMBER	DESCRIPTION	WT. (LBS)	LIST
04579202	CVCBX	Ceiling Bracket*	1/2	27
04578602	CVB42X	42" Blank Section	6	83
04578702	CVB60X	60" Blank Section	8	120
04578802	CVB84X	84" Blank Section	12	158

*Order 2 for units up to 72"
Order 3 for units over 72"

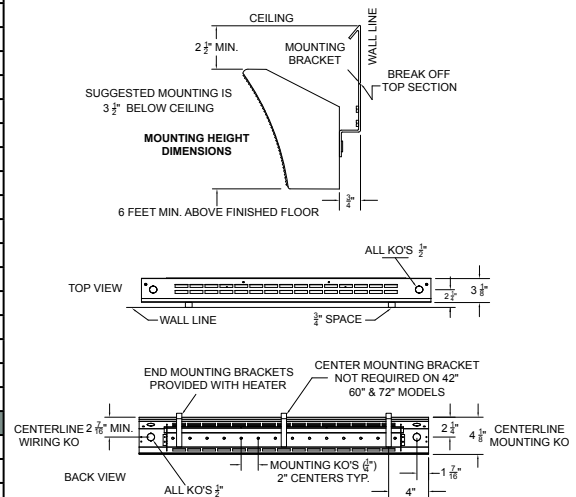

WARNING: This product can expose you to chemicals including nickel which is known to the State of California to cause cancer, and chromium, which is known to the State of California to cause birth defects and/or reproductive harm. For more information go to www.P65Warnings.ca.gov.

305 Series Midsized Commercial Fan Forced Wall Heater - Multiple Wattage



Features

- Wattage selectable at time of installation
- Models shipped wired to highest wattage
- Approved for horizontal mounting - right or left discharge
- Fan purge circuit
- Disconnect switch
- Drywall depth embossments on back can
- Thermostat knob included with unit
- 18 gauge powder coated steel & extruded Aluminum front
- Manual reset thermal limit
- Steel block fin element
- Propeller style fan blade: 1060 RPM motor; 100 CFM
- Weight = 6 lbs.
- Rough in dimensions: 9 ¼" Wide x 12 ½" High x 3 ⅝" Deep
- Grill dimensions: 10" Wide x 13 ⅞" High
- Approved for wall or ceiling installation
- Made in U.S.A.

Standard Models

MFG CATALOG NUMBER	MFG MODEL NUMBER	SELECTABLE INSTALLATION WATTAGE	MAX BTUs	VOLTS	MAX AMPS	LIST
TAMPERPROOF IN-BUILT DOUBLE POLE THERMOSTAT (40° - 100° TEMPERATURE RANGE)						
09962102	E3055T2DWB	750 or 1500	5120	120	12.5	519
09962202	E3058T2DWB	900 or 1800	6143	120	15.0	517
09962502	F3052T2DWB	1000 or 2000	6826	208	8.3	517
09456902	F30522T2DWB	500 or 750 or 1000 or 1250 or 1500 or 1750 or 2250	7680	208	10.8	599
09962802	H3052T2DWB	750 or 1000 - 1500 or 2000	6826	208 / 240	8.3	520
09457202	H30522T2DWB	500 or 750 or 1000 or 1250 or 1500 or 1750 or 2250	7680	240	9.4	596
09963102	G3052T2DWB	2000	6826	277	7.2	528

Accessories

MFG CATALOG NUMBER	MFG MODEL NUMBER	DESCRIPTION	LIST
09969402	305EX8	1" EXTENDER	72
09969302	305EX16	2" EXTENDER	74
09969202	305EX32	4" SURFACE MOUNT FRAME	86

Note: Please see Draft Barrier Heaters - General Product Information page for custom color availability; add 10% to net heater cost.

4400 Series Low Profile Commercial Fan Forced Wall Heater - With Wall Box

- Powder coated 20 gauge steel front with extruded Aluminum frame
- Manual reset thermal limit
- Finned tubular steel element
- Propeller style fan blade - 2200 RPM/70 CFM
- Weight 9 lbs.
- Rough in dimensions:
 - 14 ½" wide x 7 ⅞" high x 3 ½" deep
 - Grill dimensions: 16 ⅞" wide x 8" high
- Unit not approved for ceiling mount applications
- Unit can be positioned to allow left, right or top discharge
- Made in U.S.A.



Standard Models

MFG CATALOG NUMBER	MFG MODEL NUMBER	VOLTS	WATTS	MAX BTUs	AMPS	LIST
DOUBLE POLE IN-BUILT THERMOSTAT (RANGE 0° - 110° F)						
03283202	F4420T2RP	208	2000	6826	9.6	528
03283302	HF4475T2RP	240/208	750 / 562	2560 / 1920	3.1 / 2.7	
03283402	HF4410T2RP	240/208	1000 / 750	3413 / 2560	4.2 / 3.6	
03283502	HF4415T2RP	240/208	1500 / 1125	5120 / 3840	6.3 / 5.4	
03283602	HF4420T2RP	240/208	2000 / 1500	6826 / 5120	8.3 / 7.2	
SINGLE POLE IN-BUILT THERMOSTAT (RANGE 0° - 110° F)						
03283702	E4475TRP	120	750	2560	6.25	496
03283802	E4410TRP	120	1000	3413	8.33	
03283902	E4415TRP	120	1500	5120	12.5	
03284002	F4420TRP	208	2000	6826	9.6	

Accessories

MFG CATALOG NUMBER	MFG MODEL NUMBER	DESCRIPTION	WT. (LBS)	LIST
03299102	4400EX8	1" SEMI RECESSING EXTENDER	2	77
03299002	4400EX16	2" SEMI RECESSING EXTENDER	3	82
03298902	4400EX32	4" SURFACE MOUNTING FRAME	4	86
03284402	4300PB	WALL PLATE ADAPTOR (OD 21.5"x12.25")	1	57

Note: Please see Draft Barrier Heaters - General Product Information page for custom color availability; add 10% to net heater cost.

3340 Series Heavy Duty Wall Heater



Features

- Dual vane axial fan blades
- Lockable disconnect switch
- Automatic purge
- Manual reset thermal limit
- Low voltage control
- Steel block fin elements
- Optional built in thermostat with 40° - 110°F range
- Heavy duty 18 gauge powder coated grille
- Extruded aluminum trim frame, no visible screws
- 4" Surface mounting frame included (3340EX32)
- Rough in dimensions 30-1/2 in wide x 19-1/2 in high x 4" deep
- When ordered without thermostat, terminal block included for field connection of remote low voltage single stage thermostat
- Models offered with BMS relay. (relay requires field supplied 24V source)
- Optional 2" semi recess frame available (3340EX16)
- Made in U.S.A.

WARNING: This product can expose you to chemicals including nickel which is known to the State of California to cause cancer, and chromium, which is known to the State of California to cause birth defects and/or reproductive harm. For more information go to www.P65Warnings.ca.gov.



Product Specifications

Furnish and install Heavy-Duty Forced Air wall heaters, where specified. The heaters shall be constructed of a heavy 18 gauge steel housing with an extruded Aluminum frame. The rough-in dimensions are 30 1/2" Wide x 19 1/2" High x 4" Deep. The units shall be available in ratings of 6000,8000, & 9600 watts at 208 volt (1 or 3Ø), 240 volt (1 or 3Ø), 277 volt (1Ø), & 480 volt (3Ø). The heaters shall have (2) low-speed 600 RPM, 4-pole motors which drives vane axial blowers to deliver a quiet 350 CFM of down flow air. The two heating elements shall be of the sealed tubular type with large, parallel steel fins for quick heat transfer. Units shall have as a standard, a manual reset thermal overload cut-off for added safety, fan delay switch, and manual disconnect switch. Optional built-in tamper proof thermostat which shall be calibrated to provide a range of 0°F. to 110°F. An optional 24 volt control relay* shall be installed for control from Building Management System (BMS). Optional accessory shall include a semi-recess mounting adapter and a 16 gauge Heavy Duty Grille. All heaters shall be listed by ETL. The heating element shall be supplied with a manufacturer's 1-year limited warranty.



Standard Models

MODEL LISTING FOR BROWN MODELS														
MFG CATALOG NUMBER	MFG MODEL NUMBER	MFG CATALOG NUMBER	MFG MODEL NUMBER	MFG CATALOG NUMBER	MFG MODEL NUMBER	MFG CATALOG NUMBER	MFG MODEL NUMBER	WATTS	BTUs	VOLTS	PHASE	AMPS	WT. (LBS)	LIST
NO STAT / NO RELAY		WITH STAT ONLY		RELAY ONLY		WITH STAT AND RELAY								
04759602	F3346	04758402	F3346T	04761002	F3346-BMS	04762302	F3346T-BMS	6000	20478	208	1	30.64	68	3695
04759702	H3346	04758502	H3346T	04761102	H3346-BMS	04762402	H3346T-BMS	6000	20478	240	1	26.6	68	3695
04759802	G3346	04760902	G3346T	04761202	G3346-BMS	04762502	G3346T-BMS	6000	20478	277	1	23.3	68	3695
04759902	J3346	04758602	J3346T	04761302	J3346-BMS	04762602	J3346T-BMS	6000	20478	208	3	18.5	68	3695
04760002	K3346	04758702	K3346T	04761402	K3346-BMS	04762702	K3346T-BMS	6000	20478	240	3	16.1	68	3695
04760102	P3346	04758802	P3346T	04761502	P3346-BMS	04762802	P3346T-BMS	6000	20478	480	3	8.0	68	3695
04760202	G3348	04758902	G3348T	04761602	G3348-BMS	04762902	G3348T-BMS	8000	27304	277	1	30.5	68	4488
04760302	J3348	04759002	J3348T	04761702	J3348-BMS	04763002	J3348T-BMS	8000	27304	208	3	24.0	68	4488
04760402	K3348	04759102	K3348T	04761802	K3348-BMS	04763102	K3348T-BMS	8000	27304	240	3	20.9	68	4488
04760502	P3348	04759202	P3348T	04761902	P3348-BMS	04763202	P3348T-BMS	8000	27304	480	3	10.5	68	4488
04760602	J3349	04759302	J3349T	04762002	J3349-BMS	04763302	J3349T-BMS	9600	32765	208	3	28.5	68	5279
04760702	K3349	04759402	K3349T	04762102	K3349-BMS	04763402	K3349T-BMS	9600	32765	240	3	24.7	68	5279
04760802	P3349	04759502	P3349T	04762202	P3349-BMS	04763502	P3349T-BMS	9600	32765	480	3	12.4	68	5279

Optional Accessories

MFG CATALOG NUMBER	MFG MODEL NUMBER	LIST
04764102	3340EX16 - Semi Recess Frame	370
---	Add HD (Suffix) 16 Gauge HD Grille	476

3340 Series are custom built and subject to 100% cancellation/restock charges.

3340 Series Heavy Duty Wall Heater

Features



- Dual vane axial fan blades
- Lockable disconnect switch
- Automatic purge
- Manual reset thermal limit
- Low voltage control
- Steel block fin elements
- Optional built in thermostat with 40° - 110°F range
- Heavy duty 18 gauge powder coated grille
- Extruded aluminum trim frame, no visible screws
- 4" Surface mounting frame included (3340EX32)
- Rough in dimensions 30-1/2 in wide x 19-1/2 in high x 4" deep
- When ordered without thermostat, terminal block included for field connection of remote low voltage single stage thermostat
- Models offered with BMS relay. (relay requires field supplied 24V source)
- Optional 2" semi recess frame available (3340EX16)
- Made in U.S.A.

WARNING: This product can expose you to chemicals including nickel which is known to the State of California to cause cancer, and chromium, which is known to the State of California to cause birth defects and/or reproductive harm. For more information go to www.P65Warnings.ca.gov.



Product Specifications

Furnish and install Heavy-Duty Forced Air wall heaters, where specified. The heaters shall be constructed of a heavy 18 gauge steel housing with an extruded Aluminum frame. The rough-in dimensions are 30 1/2" Wide x 19 1/2" High x 4" Deep. The units shall be available in ratings of 6000,8000, & 9600 watts at 208 volt (1 or 3Ø), 240 volt (1 or 3Ø), 277 volt (1Ø), & 480 volt (3Ø). The heaters shall have (2) low-speed 600 RPM, 4-pole motors which drives vane axial blowers to deliver a quiet 350 CFM of down flow air. The two heating elements shall be of the sealed tubular type with large, parallel steel fins for quick heat transfer. Units shall have as a standard, a manual reset thermal overload cut-off for added safety, fan delay switch, and manual disconnect switch. Optional built-in tamper proof thermostat which shall be calibrated to provide a range of 0°F. to 110°F. An optional 24 volt control relay* shall be installed for control from Building Management System (BMS). Optional accessory shall include a semi-recess mounting adapter and a 16 gauge Heavy Duty Grille. All heaters shall be listed by ETL. The heating element shall be supplied with a manufacturer's 1-year limited warranty.

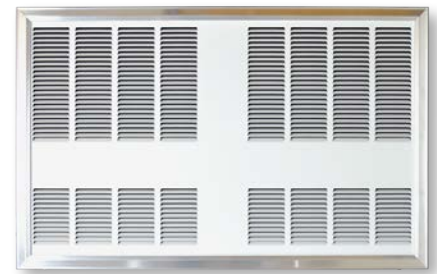

Standard Models

MODEL LISTING FOR WHITE MODELS														
MFG CATALOG NUMBER	MFG MODEL NUMBER	MFG CATALOG NUMBER	MFG MODEL NUMBER	MFG CATALOG NUMBER	MFG MODEL NUMBER	MFG CATALOG NUMBER	MFG MODEL NUMBER	WATTS	BTUs	VOLTS	PHASE	AMPS	WT. (LBS)	LIST
NO STAT / NO RELAY		WITH STAT ONLY		RELAY ONLY		WITH STAT AND RELAY								
04917602	F3346-W	04918902	F3346T-W	04920202	F3346-BMS-W	04921502	F3346T-BMS-W	6000	20478	208	1	30.64	68	3695
04917702	H3346-W	04919002	H3346T-W	04920302	H3346-BMS-W	04921602	H3346T-BMS-W	6000	20478	240	1	26.6	68	3695
04917802	G3346-W	04919102	G3346T-W	04920402	G3346-BMS-W	04921702	G3346T-BMS-W	6000	20478	277	1	23.3	68	3695
04917902	J3346-W	04919202	J3346T-W	04920502	J3346-BMS-W	04921802	J3346T-BMS-W	6000	20478	208	3	18.5	68	3695
04918002	K3346-W	04919302	K3346T-W	04920602	K3346-BMS-W	04921902	K3346T-BMS-W	6000	20478	240	3	16.1	68	3695
04918102	P3346-W	04919402	P3346T-W	04920702	P3346-BMS-W	04922002	P3346T-BMS-W	6000	20478	480	3	8.0	68	3695
04918202	G3348-W	04919502	G3348T-W	04920802	G3348-BMS-W	04922102	G3348T-BMS-W	8000	27304	277	1	30.5	68	4488
04918302	J3348-W	04919602	J3348T-W	04920902	J3348-BMS-W	04922202	J3348T-BMS-W	8000	27304	208	3	24.0	68	4488
04918402	K3348-W	04919702	K3348T-W	04921002	K3348-BMS-W	04922302	K3348T-BMS-W	8000	27304	240	3	20.9	68	4488
04918502	P3348-W	04919802	P3348T-W	04921102	P3348-BMS-W	04922402	P3348T-BMS-W	8000	27304	480	3	10.5	68	4488
04918602	J3349-W	04919902	J3349T-W	04921202	J3349-BMS-W	04922502	J3349T-BMS-W	9600	32765	208	3	28.5	68	5279
04918702	K3349-W	04920002	K3349T-W	04921302	K3349-BMS-W	04922602	K3349T-BMS-W	9600	32765	240	3	24.7	68	5279
04918802	P3349-W	04920102	P3349T-W	04921402	P3349-BMS-W	04922702	P3349T-BMS-W	9600	32765	480	3	12.4	68	5279

Optional Accessories

MFG CATALOG NUMBER	MFG MODEL NUMBER	LIST
04764202	3340EX16-W - Semi Recess Frame	370
---	Add HD (Suffix) 16 Gauge HD Grille	476

3340 Series are custom built and subject to 100% cancellation/restock charges.

3320 Series Commercial Fan Forced Wall Heater



Features

- Disconnect switch
- Automatic fan delay circuit
- Automatic reset thermal limit
- Powder coated 18 gauge steel grill with extruded
- Aluminum front frame
- Steel block fin element
- Vane axial fan blade: 600 RPM motor; 175
- Rough-in dimensions: 14 1/8" Wide x 19 1/2" High x 4" Deep
- Grill dimensions: 15 29/32" Wide x 20 27/32" High
- Built-In tamper proof thermostat
- Made in U.S.A.

WARNING: This product can expose you to chemicals including nickel which is known to the State of California to cause cancer, and chromium, which is known to the State of California to cause birth defects and/or reproductive harm. For more information go to www.P65Warnings.ca.gov.



Product Specifications

Heavy-duty forced air wall heaters, where specified. The heaters shall be constructed of a heavy 18 gauge steel housing with an extruded Aluminum frame. The rough-in dimensions are 14 1/8" Wide x 19 1/2" High x 4" Deep. The units shall be available in ratings from 750 to 4800 Watts at 240, 208, and 277 Volts. The heaters shall have a low-speed 600 RPM, 4-pole motor

which drives a vane axial blower to deliver a quiet 175 CFM of down flow air. The heating element shall be of the sealed tubular type with large, parallel steel fins for quick heat transfer. Unit shall have as a standard, a thermal overload cut-off for added safety, fan delay switch and built-in tamper proof thermostat which shall be calibrated to provide a range of 0°F. to 110°F. and manual disconnect switch. Optional accessories shall include a surface and semi-recess mounting adapter. All heaters shall be listed by ETL. The heating element shall be supplied with a manufacturer's 1-year limited warranty.

Standard Models

MFG CATALOG NUMBER	MFG MODEL NUMBER	WATTS	BTUs	VOLTS	AMPS	WT. (lbs)	LIST
IN-BUILT SINGLE POLE TAMPER-PROOF THERMOSTAT (0°F - 110°F TEMPERATURE RANGE) FOR DOUBLE POLE THERMOSTAT REPLACE "T" IN MODEL NUMBER WITH "T2" -- ADD \$53							
1-Phase							
03820502	E3321TD-RP	750	2560	120	6.25	26	1054
03819902	E3322TD-RP	1000	3413	120	8.3	26	1054
03808802	E3323TD-RP	1500	5120	120	12.5	26	1055
03809302	F3326TD-RP	4000	13649	208	19.2	26	1075
03810202	F3327TD-RP	4800	16378	208	23	26	1128
03809402	HF3323TD-RP	1500 / 1125	5120 / 3840	240 / 208	6.2 / 5.4	26	1075
03809502	HF3324TD-RP	2000 / 1500	6824 / 5120	240 / 208	8.3 / 7.2	27	1075
03809602	HF3325TD-RP	3000 / 2250	10236 / 7677	240 / 208	12.5 / 10.8	29	1075
03809702	HF3326TD-RP	4000 / 3000	13649 / 7677	240 / 208	16.7 / 14.4	29	1075
03810302	H3327TD-RP	4800	16378	240	20	29	1115
03809802	G3323TD-RP	1500	5120	277	4.1	26	1073
03809902	G3324TD-RP	2000	6824	277	7.2	27	1073
03810002	G3325TD-RP	3000	7677	277	10.8	29	1073
03810102	G3326TD-RP	4000	13649	277	14.4	29	1073
03810402	G3327TD-RP	4800	16378	277	17.3	29	1104
International Models							
03964202	M3324TD-RPi	3360 / 1680	6824 / 5732	220	15.3 / 7.64	27	1075
03964302	M3325TD-RPi	4032 / 2016	13761 / 6879	220	18.3 / 9.16	27	1075

Accessories

MFG CATALOG NUMBER	MFG MODEL NUMBER	DESCRIPTION	TYPE	WT. (LBS)	LIST
03778502	BOX 3310	Additional Rough-in Box	Field Installed	3	164
03784502	3320EX33	4" Surface Mounting Frame		1	154
03829302	3320EX16	2" Semi Recess Extender		1	131
----	Suffix - HD	16 Gauge Steel Heavy Duty Grill	Factory Installed	2	168
----	Suffix - R	24V BMS Relay	Factory Installed	1	150

3320 Series Commercial Fan Forced Wall Heater

Features

* NOW AVAILABLE *

480V MODELS



- Disconnect switch
- Automatic fan delay circuit
- Automatic reset thermal limit
- Powder coated 18 gauge steel grill with extruded Aluminum front frame
- Steel block fin element
- Vane axial fan blade: 600 RPM motor; 175 CFM
- Rough-in dimensions: 14 1/8" wide x 19 1/2" high x 4" deep
- Grill dimensions: 15 29/32" Wide x 20 27/32" High
- Built-In tamper proof thermostat
- Made in U.S.A.

WARNING: This product can expose you to chemicals including nickel which is known to the State of California to cause cancer, and chromium, which is known to the State of California to cause birth defects and/or reproductive harm. For more information go to www.P65Warnings.ca.gov.



Product Specifications

Heavy-duty forced air wall heaters, where specified. The heaters shall be constructed of a heavy 18 gauge steel housing with an extruded Aluminum frame. The rough-in dimensions are 14 1/8" Wide x 19 1/2" High x 4" Deep. The units shall be available in ratings from 3000 to 4800 Watts at 240, 208, and 277 Volts. The heaters shall have a low-speed 600 RPM, 4-pole motor which drives a vane axial blower to deliver a quiet 175 CFM of down flow air. The heating element shall be of the sealed tubular type with large, parallel steel fins for quick heat transfer. Unit shall have as a standard, a thermal overload cut-off for added safety, fan delay switch and built-in tamper proof thermostat which shall be calibrated to provide a range of 0°F. to 110°F. and manual disconnect switch. Optional accessories shall include a surface and semi-recess mounting adapter. All heaters shall be listed by ETL. The heating element shall be supplied with a manufacturer's 1-year limited warranty.

Standard Models

MFG CATALOG NUMBER	MFG MODEL NUMBER	WATTS	BTUs	VOLTS	AMPS	WT. (LBS)	LIST
IN-BUILT SINGLE POLE TAMPER-PROOF THERMOSTAT (0°F - 110°F TEMPERATURE RANGE)							
3-Phase							
04763602	J3325TD-RP	3000	10239	208	8.3	30	1265
04763702	K3325TD-RP	3000	10239	240	7.2	30	1265
04763802	P3325T-RP	3000	10239	480*	3.6	30	1265
03980702	J3326TD-RP	4000	13649	208	11.11	30	1291
03980902	K3326TD-RP	4000	13649	240	9.64	30	1291
04763902	P3326T-RP	4000	13652	480*	4.8	30	1291
03980802	J3327TD-RP	4800	16378	208	13.33	30	1355
03981002	K3327TD-RP	4800	16378	240	11.57	30	1355
04764002	P3327T-RP	4800	16382	480*	5.8	30	1355

*Disconnect switch not available on 480V units

Accessories

MFG CATALOG NUMBER	MFG MODEL NUMBER	DESCRIPTION	TYPE	WT. (LBS)	LIST
03778502	BOX 3310	Additional Rough-in Box	Field Installed	3	164
03784502	3320EX33	4" Surface Mounting Frame		1	154
03829302	3320EX16	2" Semi Recess Extender		1	131
----	Suffix - HD	16 Gauge Steel Heavy Duty Grill	Factory Installed	2	168
----	Suffix - R	24V BMS Relay	Factory Installed	1	150

3420 & 3450 Series Heavy-Duty Fan Forced Wall Heaters



Without Tamper Proof Cover

WARNING: This product can expose you to chemicals including nickel which is known to the State of California to cause cancer, and chromium, which is known to the State of California to cause birth defects and/or reproductive harm. For more information go to www.P65Warnings.ca.gov.

Features

- Powder coated bar stock steel tamper proof grille, with extruded Aluminum frame and 16-gauge housing
- In-built double pole tamper proof thermostat with a 40°-120°F temperature range and positive off; 3 phase heaters have 3 pole thermostat for positive off position with a 40°-120°F temperature range
- Manual reset thermal limit switch
- Corrosion resistant steel tubular element with brazed steel fins
- Permanently lubricated, unit bearing, shaded pole motor with impedance protection
- Propeller type fan blade:
 - Made in U.S.A.
- 400 RPM motor; 245 CFM
 - Wall box included with heater
- Factory installed options:
 - contactors (3420 / 3450 Series)
 - control transformer (3450 series)



Standard Models

HEATER		WALL BOX		WATTS	BTUs	VOLTS	PH	AMPS	WT. (LBS)	HEATER LIST
MFG CATALOG NUMBER	MFG MODEL NUMBER	MFG CATALOG NUMBER	MFG MODEL NUMBER							
SERIES 3420 - ROUGH-IN DIMENSIONS: 19 5/8" H x 14 3/16" W x 4 1/8" D GRILL DIMENSIONS: 21 1/2" H x 17 1/2" W										
06911302	F3422T	06915702	Box 3420	2000	6826	208	1	9.6	41	1776
06911902	H3422T			2000	6826	240	1	8.3		1776
06911702	G3422T			2000	6826	277	1	7.2		1776
03846202	J3422T			2000	6826	208	3	5.6		2039
03846402	K3422T			2000	6826	240	3	4.8		2039
06912302	F3423T			3000	10239	208	1	14.4		1814
06913102	H3423T			3000	10239	240	1	12.5		1814
06912702	G3423T			3000	10239	277	1	10.8		1794
03238502	J3423T			3000	10239	208	3	8.3		2039
03846502	K3423T			3000	10239	240	3	7.3		2039
06913302	F3424T			4000	13652	208	1	19.2		1846
06913802	H3424T			4000	13652	240	1	16.7		1846
06913602	G3424T			4000	13652	277	1	14.4		1846
06914002	J3424T			4000	13652	208	3	11.1		2039
06914102	K3424T			4000	13652	240	3	9.6		2039
06914302	F3425T			5000	17065	208	1	24		2061
06915102	H3425T			5000	17065	240	1	20.8		2061
06914802	G3425T			5000	17065	277	1	18.1		2061
06915302	J3425T			5000	17065	208	3	13.9		2216
06915602	K3425T			5000	17065	240	3	12.0		2216

HEATER		WALL BOX		WATTS	BTUs	VOLTS	PH	AMPS	WT. (LBS)	HEATER LIST
MFG CATALOG NUMBER	MFG MODEL NUMBER	MFG CATALOG NUMBER	MFG MODEL NUMBER							
SERIES 3450 - ROUGH-IN DIMENSIONS: 23 5/8" H x 14 3/16" W x 4 1/8" D GRILL DIMENSIONS: 25" H x 17 1/2" W										
04765502	F3452T1D	06919102	Box 3450	2000	6826	208	1	9.6	55	2245
04765602	H3452T1D			2000	6826	240	1	8.3		2245
04765702	F3453T1D			3000	10239	208	1	14.4		2460
04765802	H3453T1D			3000	10239	240	1	12.5		2460
04765902	F3454T1D			4000	13652	208	1	19.2		2320
04766001	H3454T1D			4000	13652	240	1	16.7		2209
04766102	F3455T1D			5000	17065	208	1	24.1		2524
04766202	H3455T1D			5000	17065	240	1	20.8		2524
04766302	G3452T1D			2000	6826	277	1	7.2		2245
04766402	G3453T1D			3000	10239	277	1	10.8		2460
04766502	G3454T1D			4000	13652	277	1	14.4		2320
04766602	G3455T1D			5000	17065	277	1	18.1		2524
04767902	J3452T1DR			2000	6826	208	3	5.6		2512
04768002	J3453T1DR			3000	10239	208	3	8.3		2512
04768102	J3454T1DR			4000	13652	208	3	11.1		2512
04768202	J3455T1DR			5000	17065	208	3	13.9		2739
04768302	K3452T1DR			2000	6826	240	3	4.8		2512
04768402	K3453T1DR			3000	10239	240	3	7.3		2512
04768502	K3454T1DR			4000	13652	240	3	9.6		2512
04768602	K3455T1DR			5000	17065	240	3	12		2739

Notes: Please see Draft Barrier Heaters - General Product Information page for custom color availability - add 10% to net heater cost; Products listed in this section are custom built and subject to 100% cancellation/restocking charges.

Contractor shall supply and install heavy duty wall mounted forced air electric heaters of the wattage, voltage and phase as specified. The heater shall so be designed to provide an even distribution of heated air to the space to be heated by drawing return air in the peripheral area of the heater across and through the element which shall then be discharged from the center section of the heater by means of an electric motor and axial flow fan blade. Heaters shall be recessed type to extend no more than 1 ½" from the finished wall or surface mounted to extend no more than 5 ¾" from the finished wall or semi-recessed type to extend no more than 3 ½" from finished wall or semi-recessed type to extend no more than 2 ½" from finished wall.

ENCLOSURE:

Heater front shall withstand 10.8 ft. lbs. (324 poundals) impact and 400 lbs. static force applied to an 8 sq. in. area at center grille location with less than ¼" permanent distortion. The combination return and supply grille assembly shall be constructed of ¼" x ¾" rounded edge horizontal steel louvers which shall be spaced for maximum opening of ¼". Louvers shall be welded at every intersection to three evenly spaced 1/16" diameter vertical members and completely framed in a heavy gauge natural anodized Aluminum extrusion. Front assembly shall be attached to the chassis by hidden tamper-resistant (Allen-head) machine screws. All other parts shall be 16 gauge steel Zinc coated, both sides finished in a bronze colored baked powder coat finish.

MOTOR:

Motor shall be a permanently lubricated unit bearing, totally enclosed shaded pole type with impedance protection. Motors shall operate at no more than 1400 RPM and shall be same voltage as the heater. A protective shield shall surround the motor to separate return air from heated air.

PERFORMANCE:

Heaters shall have a rating of 245 CFM at 660 F.P.M. with a maximum temperature rise of 73°F.

ELEMENTS:

Element assemblies shall consist of two or three corrosion resistant steel sheathed type elements mechanically bonded to common corrosion resistant steel fins. Each sheathed element shall consist of helically coiled Nickel Chromium alloy resistant wire completely embedded in and surrounded by Magnesium Oxide, enclosed and wedged into corrosion resistant steel sheaths. Elements shall have 2" cold conductor pins extending into the sheath and shall have a density of no more than 60 Watts per inch.

THERMAL OVERLOAD:

Heaters shall be equipped with a "manual reset" thermal overload which disconnects elements and motor in the event normal operating temperatures are exceeded. For safety, if opened due to abnormal temperature, thermal overload shall remain open until manually reset. Automatic reset thermal overloads which allow the element to continue to cycle under abnormal conditions will not be accepted.

APPROVAL:

Heaters shall be ETL Listed.

3450 CONTROL SYSTEM:

Single phase heaters shall be provided with disconnect and thermostat, three phase heaters shall be provided with disconnect, thermostat and line voltage contactor. The disconnect switch will break all ungrounded conductors and shall be lockable per the N.E.C. The thermostat shall be of the tamper-proof hydraulic design with a temperature range of 40°F - 110°F. Optional 24V transformer and contactor shall be provided with a terminal block for connection to a low voltage wall mounted thermostat or BMS. The heater will be provided with a tamper-proof cover to prevent adjustment by unauthorized personnel.

3420 CONTROL SYSTEM:

Heaters will be provided with thermostat of the tamper-proof hydraulic design with a temperature range of 40°F - 120°F. The thermostat will serve as a disconnect switch in the "off" position, breaking all breaking all ungrounded conductors. An optional 24V contactor shall be provided with connections for field supplied 24V or connection to BMS. The heater will be provided with a tamper-proof cover to prevent adjustment by unauthorized personnel.

CONTACTORS:

Where required, heaters shall be equipped with a heavy-duty, definite purpose contactor with flame path separators. Contactors shall cycle all ungrounded conductors. Contactor shall have holding a coils of 24V.

CONTROL TRANSFORMERS:

Heater shall be equipped with a Class 2 control transformer if permitted, sealed rating of 20 VA, to supply control circuits of 24V

3420 & 3450 Series Heavy-Duty Fan Forced Wall Heaters

Factory Installed Accessories

- 3-phase units will include 24V controls.
- 24V control (R1A1 suffix) optional on single phase units.

MFG MODEL NUMBER	DESCRIPTION	SERIES OPTIONS		LIST
		3420	3450	
Suffix - R1	Contactors with 24V Coil	YES	YES	298
Suffix - A1	Control Transformers With 24V Secondary	NO	YES	164

MFG CATALOG NUMBER	MFG MODEL NUMBER	DESCRIPTION	WT. (LBS)	LIST
06916002	3420EX34	4" Surface Mounting Sleeve	5	166
06915902	3420EX16	2" Semi-Recessing Sleeve	4	158
06915802	3420EX8	1" Semi-Recessing Sleeve	3	129
06915702	Box 3420	3420 Wall Box	4	256
06919402	3450EX34	4" Surface Mounting Sleeve	6	166
06919302	3450EX16	2" Semi-Recessing Sleeve	4	158
06919202	3450EX8	1" Semi-Recessing Sleeve	3	129
06919102	Box 3450	3450 Wall Box	5	298

3450SD Series Setback on Demand Heavy-Duty Fan Forced Wall Heaters

Features



3450SD White Without Tamper Proof Cover



3450SD Bankers Bronze (Tamper Proof)

- Heavy duty architectural style
- Automatic fan purge circuit
- Manual reset thermal limit switch
- Powder coated bar stock grill with extruded Aluminum frame and 16-gauge housing
- Set desired comfort level and set-back level up to 12°F
- The thermostat learns your schedule based on detected movement and returns the area to the desired temperature using two stage operation. If the thermostat does not detect movement within one hour, setback occurs to the preset level
- Occupancy sensor defaults to economy mode after one hour, sensor has a 94 degree angular range and a 16' linear range
- Tamper proof grill covers the thermostat
- Corrosion resistant steel tubular element with brazed steel fins
- Permanently lubricated, unit bearing, shaded pole motor with impedance protection
- Factory preset to correct operating system voltage of heater
- Propeller type fan blade: -1400 RPM motor; 245 CFM
- Wall box included with heater
- Available in white, consult factory
- Made in USA



Standard Models

HEATER		WATTS	BTUs	VOLTS	PH	AMPS	WT. (LBS)	LIST
MFG CATALOG NUMBER	MFG MODEL NUMBER							
SERIES 3450SD - ROUGH-IN DIMENSIONS: 23 1/8" H x 14 1/4" W x 4 1/4" D								
GRILL DIMENSIONS: 25 1/2" H x 17 1/6" W								
03985102	F3452SD	2000	6826	208	1	9.6	55	3673
03985202	H3452SD	2000	6826	240	1	8.3		3673
03985302	G3452SD	2000	6826	277	1	7.2		3673
03985402	J3452SD	2000	6826	208	3	5.6		3940
03985502	K3452SD	2000	6826	240	3	4.8		3940
03985602	F3453SD	3000	10239	208	1	14.4		3698
03985702	H3453SD	3000	10239	240	1	12.5		3698
03985802	G3453SD	3000	10239	277	1	10.8		3698
03985902	J3453SD	3000	10239	208	3	8.3		3940
03986002	K3453SD	3000	10239	240	3	7.3		3940
03986102	F3454SD	4000	13652	208	1	19.2		3747
03986202	H3454SD	4000	13652	240	1	16.7		3747
03986302	G3454SD	4000	13652	277	1	14.4		3747
03986402	J3454SD	4000	13652	208	3	11.1		3940
03986502	K3454SD	4000	13652	240	3	9.6		3940
03986602	F3455SD	5000	17065	208	1	24.03		3952
03986702	H3455SD	5000	17065	240	1	20.8	3952	
03986802	G3455SD	5000	17065	277	1	18.1	3952	
03986902	J3455SD	5000	17065	208	3	13.9	4168	
03987002	K3455SD	5000	17065	240	3	12.0	4168	

3310 Series Fan Forced Wall Heater - Without Summer Fan Switch



Features

- Powder coated 18-gauge steel front
- Automatic reset thermal limit
- Vane axial fan blade: 600 RPM / 175 CFM
- Rough in dimensions:
- 14 1/8" Wide x 19 1/2" High x 4" Deep
- Grill dimensions: 16 3/16" Wide x 21" High
- Steel block fin element
- Tamper proof plug button included with unit
- Weight 22 lbs.
- Units with dual wattage, factory wired to highest wattage
- Wattage selectable at time of installation on some models
- Made in U.S.A.



Standard Models

MODELS WITH IN-BUILT DOUBLE POLE THERMOSTAT (0° - 110° F TEMPERATURE RANGE)								
IVORY		WHITE		WATTS	MAX BTUs	VOLTS	AMPS	LIST
MFG CATALOG NUMBER	MFG MODEL NUMBER	MFG CATALOG NUMBER	MFG MODEL NUMBER					
03263402	E3312TRP	03264802	E3312TRPW	1000	3413	120	8.3	786
03263502	E3313TRP	03264902	E3313TRPW	1500	5120	120	12.5	786
				750	2560	120	6.25	786
03263602	F3316TRP	03265002	F3316TRPW	4000	13648	208	19.2	797
03263702	F3317TRP	03265102	F3317TRPW	4800	16380	208	23	819
03264002	HF3315TRP	03265402	HF3315TRPW	3000 / 2250	10240	240 / 208	12.5 / 10.8	796
				1500 / 1125	5120	241 / 208	6.2 / 5.4	796
03264102	HF3316TRP	03265502	HF3316TRPW	4000 / 3000	13648	242 / 208	16.8 / 14.4	797
				2000 / 1500	6826	243 / 208	8.3 / 7.2	797
03264202	H3317TRP	03265602	H3317TRPW	4800	16380	240	20.0	837
03264302	G3314TRP	03265702	G3314TRPW	2000	6826	277	7.2	796
03264402	G3315TRP	03265802	G3315TRPW	3000	10240	277	10.8	796
03264502	G3316TRP	03265902	G3316TRPW	4000	13648	277	14.4	796
03264602	G3317TRP	03266002	G3317TRPW	4800	16380	277	17.3	823
MODELS WITH IN-BUILT SINGLE POLE THERMOSTAT (0° - 110° F TEMPERATURE RANGE)								
03825202	E3312TRP	03826102	E3312TRPW	1000	3413	120	8.3	733
03806502	E3313TRP	03841602	E3313TRPW	1500	5120	120	12.5	733
				750	2560	120	6.25	733
03799402	F3316TRP	03841802	F3316TRPW	4000	13648	208	19.2	745
03803002	F3317TRP	03841902	F3317TRPW	4800	16380	208	23	765
03805602	HF3315TRP	03822202	HF3315TRPW	3000 / 2250	10240	240 / 208	12.5 / 10.8	765
				1500 / 1125	5120	241 / 208	6.2 / 5.4	765
03799802	HF3316TRP	03822302	HF3316TRPW	4000 / 3000	13648	242 / 208	16.8 / 14.4	745
				2000 / 1500	6826	243 / 208	8.3 / 7.2	745
03803102	H3317TRP	03822402	H3317TRPW	4800	16380	240	20.0	784
03805902	G3314TRP	03842602	G3314TRPW	2000	6826	277	7.2	743
03807502	G3315TRP	03842702	G3315TRPW	3000	10240	277	10.8	743
03800102	G3316TRP	03842802	G3316TRPW	4000	13648	277	14.4	743
03791702	G3317TRP	03842902	G3317TRPW	4800	16380	277	17.3	771
MODELS WITHOUT AN IN-BUILT THERMOSTAT								
03266202	E3312RP	03267602	E3312RPW	1000	3413	120	8.3	695
03266302	E3313RP	03267702	E3313RPW	1500	5120	120	12.5	695
				750	2560	120	6.25	695
03285302	F3316RP	03267802	F3316RPW	4000	13648	208	19.2	711
03266502	F3317RP	03267902	F3317RPW	4800	16380	208	23	733
03266802	HF3315RP	03268202	HF3315RPW	3000 / 2250	10240	240 / 208	12.5 / 10.8	711
				1500 / 1125	5120	241 / 208	6.2 / 5.4	711
03266902	HF3316RP	03268302	HF3316RPW	4000 / 3000	13648	242 / 208	16.8 / 14.4	711
				2000 / 1500	6826	243 / 208	8.3 / 7.2	711
03267002	H3317RP	03268402	H3317RPW	4800	16380	240	20.0	749
03267102	G3314RP	03268502	G3314RPW	2000	6826	277	7.2	710
03267202	G3315RP	03268602	G3315RPW	3000	10240	277	10.8	710
03267302	G3316RP	03268702	G3316RPW	4000	13648	277	14.4	710
03267402	G3317RP	03268802	G3317RPW	4800	16380	277	17.3	735

3310 Series Fan Forced Wall Heater - With Summer Fan Switch



WARNING: This product can expose you to chemicals including nickel which is known to the State of California to cause cancer, and chromium, which is known to the State of California to cause birth defects and/or reproductive harm. For more information go to www.P65Warnings.ca.gov.



Features

- Powder coated 18-gauge steel front
- Automatic reset thermal limit
- Steel block fin element
- Weight 22 lbs.
- Vane axial fan blade: 600 RPM / 175 CFM
- Grill dimensions: 16 3/16" wide x 21" high
- Rough in dimensions: 14 1/8" wide x 19 1/2" high x 4" deep
- Units with dual wattage, factory wired to highest wattage
- Tamper proof plug button included with unit
- Wattage selectable at time of installation on some models
- Made in U.S.A.



Ideal Applications

Offices, conference rooms, reception areas, hallways, entryways, lobbies, stairwells or small commercial spaces.



Product Specifications

Typical specifications: furnish and install electric forced air heaters where specified. The heaters shall be constructed of a heavy gauge steel housing. The rough-in dimensions are 14 1/8" wide x 19 1/2" high x 4" deep. The finish shall be powder coated paint in ivory or white color. The units shall be available in ratings from 750 through 4800 Watts. The heaters shall have a low speed 600 RPM motor which drives a vane axial blower to deliver a quiet 175 CFM of down flow air. The heating element shall be of the sealed block fin type with large, parallel steel fins for quick heat transfer.

Unit shall have a standard thermal overload cutoff for added safety, a fan switch for fan only operation, and is available with a single pole, or double pole built-in thermostat, or no thermostat. The in-built thermostat shall be calibrated to provide a range of 0° - 110°F. All heaters shall be listed by ETL. The heating element shall be supplied with a manufacturer's one year limited warranty.

Note: Fan switch not available on 277V models. 277V models are available without a fan switch on previous page.

3310 Series Fan Forced Wall Heater - With Summer Fan Switch

Standard Models

MODELS WITH IN-BUILT DOUBLE POLE THERMOSTAT (0° - 110°F TEMPERATURE RANGE)								
IVORY		WHITE		WATTS	MAX BTUs	VOLTS	AMPS	LIST
MFG CATALOG NUMBER	MFG MODEL NUMBER	MFG CATALOG NUMBER	MFG MODEL NUMBER					
03260602	E3312T2SRP	03262002	E3312T2SRPW	1000	3413	120	8.3	802
03260702	E3313T2SRP	03262102	E3313T2SRPW	1500	5120	120	12.5	802
03260702	E3313T2SRP	03262102	E3313T2SRPW	750	2560	120	6.25	802
03260802	F3316T2SRP	03262202	F3316T2SRPW	4000	13648	208	19.2	819
03260902	F3317T2SRP	03262302	F3317T2SRPW	4800	16380	208	23	839
03261202	HF3315T2SRP	03262602	HF3315T2SRPW	3000 / 2250	10240	240 / 208	12.5 / 10.8	819
03261202	HF3315T2SRP	03262602	HF3315T2SRPW	1500 / 1125	5120	240 / 208	6.2 / 5.4	819
03261302	HF3316T2SRP	03262702	HF3316T2SRPW	4000 / 3000	13648	240 / 208	16.8 / 14.4	819
03261302	HF3316T2SRP	03262702	HF3316T2SRPW	2000 / 1500	6826	240 / 208	8.3 / 7.2	819
03261402	H3317T2SRP	03262802	H3317T2SRPW	4800	16380	240	20.0	852
MODELS WITH IN-BUILT SINGLE POLE THERMOSTAT (0° - 110°F TEMPERATURE RANGE)								
03825702	E3312TSRP	03825902	E3312TSRPW	1000	3413	120	8.3	753
03796102	E3313TSRP	03840102	E3313TSRPW	1500	5120	120	12.5	753
03796102	E3313TSRP	03840102	E3313TSRPW	750	2560	120	6.25	753
03777102	F3316TSRP	03840202	F3316TSRPW	4000	13648	208	19.2	765
03777802	F3317TSRP	03840302	F3317TSRPW	4800	16380	208	23	786
03776002	HF3315TSRP	03840702	HF3315TSRPW	3000 / 2250	10240	240 / 208	12.5 / 10.8	788
03776002	HF3315TSRP	03840702	HF3315TSRPW	1500 / 1125	5120	240 / 208	6.2 / 5.4	788
03776902	HF3316TSRP	03840802	HF3316TSRPW	4000 / 3000	13648	240 / 208	16.8 / 14.4	788
03776902	HF3316TSRP	03840802	HF3316TSRPW	2000 / 1500	6826	240 / 208	8.3 / 7.2	788
03777602	H3317TSRP	03840902	H3317TSRPW	4800	16380	240	20.0	801
INTERNATIONAL MODELS								
----	----	03964802	M3315T2SRPWi	3360	11468	220	15.27	835
----	----	03964802	M3315T2SRPWi	1680	5734	220	7.64	835
----	----	03964902	M3316T2SRPWi	4032	13761	220	18.33	835
----	----	03964902	M3316T2SRPWi	2016	6881	220	9.16	835

Accessories - All 3310 Models

IVORY		WHITE		DESCRIPTION	ACCESSORY TYPE	LIST
MFG CATALOG NUMBER	MFG MODEL NUMBER	MFG CATALOG NUMBER	MFG MODEL NUMBER			
03778502	BOX3310	03778502	BOX3310	ADDITIONAL BACK CAN	Field Installed	164
03299502	3310EX33R	03299602	3310EX33WR	SURFACE MOUNTING FRAME		142
SUFFIX D				DISCONNECT SWITCH	Factory Installed	171

3310 Series Fan Forced Wall Heater - 3 Phase

MFG CATALOG NUMBER	MFG MODEL NUMBER	WATTS	MAX BTUs	VOLTS	AMPS	PHASE	LIST
03996302	J3315TD-RPW	3000	10239	208	8.33	3	896
03996602	K3315TD-RPW	3000	10239	240	7.2	3	896
03996902	P3315T-RPW	3000	10239	480	3.6	3	896
03996402	J3316TD-RPW	4000	13649	208	11.11	3	896
03996702	K3316TD-RPW	4000	13649	240	9.64	3	896
03997002	P3316T-RPW	4000	13649	480	4.8	3	896
03996502	J3317TD-RPW	4800	16378	208	13.33	3	918
03996802	K3317TD-RPW	4800	16378	240	11.57	3	918
03997102	P3317T-RPW	4800	16378	480	5.8	3	918

Accessories - 3 Phase Models

MFG CATALOG NUMBER	MFG MODEL NUMBER	DESCRIPTION	LIST
03997702	3310EX33 - BROWN	Surface Mounting Frame	142

3200 Series Midsized Fan Forced Wall Heater - With Wall Box



Shown with built-in thermostat

Features

- Units have white powder coat finish
- Approved for horizontal mounting - right or left discharge
- Drywall depth embossments on back can
- Powder coated 18-gauge steel front
- Manual reset thermal limit
- Finned tubular steel element
- Weight 6 lbs.
- Propeller style fan blade: 2200 RPM / 70 CFM
- Optional field installed In-built thermostat
- Two-wire installation
- Rough in dimensions: 9 ¼" Wide, 12 ½" high, 3 ⅝" deep
- Grill dimensions: 9 ⅝" Wide, 13" high
- Made in U.S.A.

WARNING: This product can expose you to chemicals including nickel which is known to the State of California to cause cancer, and chromium, which is known to the State of California to cause birth defects and/or reproductive harm. For more information go to www.P65Warnings.ca.gov.



Standard Models

MFG CATALOG NUMBER	MFG MODEL NUMBER	VOLTS	WATTS	MAX BTUS	AMPS	LIST
BUILT-IN DOUBLE POLE (POSITIVE OFF) THERMOSTAT 40° - 100° F RANGE						
03834602	F3220T2RPW	208	2000	6826	9.6	408
03834702	H3275T2RPW	240	750	2560	3.1	408
03834802	HF3210T2RPW	240/208	1000 / 750	3413 / 2560	4.2 / 3.6	408
03834902	HF3215T2RPW	240/208	1500 / 1125	5120 / 3840	6.3 / 5.4	408
03835002	HF3220T2RPW	240/208	2000 / 1500	6826 / 5120	8.3 / 7.2	408
03835102	HF3222T2RPW	240/208	2250 / 1688	7680 / 5762	9.4 / 8.1	408
International Models - BUILT-IN DOUBLE POLE (POSITIVE OFF) THERMOSTAT 40° - 100° F RANGE						
03963802	M3210T2RPWi	220	840	2867	3.8	418
03963902	M3215T2RPWi	220	1260	4300	5.7	418
03964002	M3220T2RPWi	220	1680	5734	7.6	398
03964102	M3222T2RPWi	220	1890	6451	8.6	418
Standard Models - BUILT-IN SINGLE POLE (POSITIVE OFF) THERMOSTAT 40° - 100° F RANGE						
03835202	E3275TRPW	120	750	2560	6.25	385
03835302	E3210TRPW	120	1000	3413	8.33	385
03835402	E3215TRPW	120	1500	5120	12.5	385
NO BUILT-IN THERMOSTAT						
03835502	E3275RPW	120	750	2560	6.25	352
03835602	E3210RPW	120	1000	3413	8.33	352
03835702	E3215RPW	120	1500	5120	12.5	352
03835802	F3220RPW	208	2000	6826	9.6	352
03835902	H3275RPW	240	750	2560	3.1	352
03836002	HF3210RPW	240/208	1000 / 750	3413 / 2560	4.2 / 3.6	352
03836102	HF3215RPW	240/208	1500 / 1125	5120 / 3840	6.3 / 5.4	352
03836202	HF3220RPW	240/208	2000 / 1500	6826 / 5120	8.3 / 7.2	352
03836302	HF3222RPW	240/208	2250 / 1688	7680 / 5762	9.4 / 8.1	352

Accessories

FIELD INSTALLED COMPONENTS			
MFG CATALOG NUMBER	MFG MODEL NUMBER	DESCRIPTION	LIST
03836402	32T1	Single Pole thermostat with positive off for 120V units 40° - 100° F	80
03836502	32T2	Double Pole thermostat with positive off for 240/208V units 40° - 100° F	91

SURFACE MOUNTED EXTENDERS & FRAMES			
WHITE		DESCRIPTION	LIST
MFG CATALOG NUMBER	MFG MODEL NUMBER		
09969702	303EX8RW	1" EXTENDER	71
09969602	303EX16RW	2" EXTENDER	72
09969502	303EX32RW	4" SURFACE MOUNT FRAME	82

4300 Series Low Profile Fan Forced Wall Heater - With Wall Box



Features

- Available in ivory or white
- Powder coated 20 gauge steel front
- Manual reset thermal limit
- Finned tubular steel element
- Weight 9 lbs.
- Propeller style fan blade - 2200 RPM / 70 CFM
- Rough in dimensions: 14 1/2" Wide, 7 1/8" High, 3 1/2" Deep
- Grill dimensions: 16 3/4" Wide, 7 5/8" High
- Unit not approved for ceiling mount applications
- Unit can be positioned to allow left, right or top discharge
- Made in U.S.A.

⚠ WARNING: This product can expose you to chemicals including nickel which is known to the State of California to cause cancer, and chromium, which is known to the State of California to cause birth defects and/or reproductive harm. For more information go to www.P65Warnings.ca.gov.



Standard Models

IVORY		WHITE		VOLTS	WATTS	MAX BTUs	AMPS	LIST
MFG CATALOG NUMBER	MFG MODEL NUMBER	MFG CATALOG NUMBER	MFG MODEL NUMBER					
DOUBLE POLE IN-BUILT THERMOSTAT (RANGE 0° - 110°F)								
03276902	F4320T2RP	03277402	F4320T2RPW	208	2000	6826	9.6	396
03277002	HF4375T2RP	03277502	HF4375T2RPW	240/208	750 / 562	2560 / 1920	3.1 / 2.7	396
03277102	HF4310T2RP	03277602	HF4310T2RPW	240/208	1000 / 750	3413 / 2560	4.2 / 3.6	396
03277202	HF4315T2RP	03277702	HF4315T2RPW	240/208	1500 / 1125	5120 / 3840	6.3 / 5.4	396
03277302	HF4320T2RP	03277802	HF4320T2RPW	240/208	2000 / 1500	6826 / 5120	8.3 / 7.2	396
International Models - DOUBLE POLE IN-BUILT THERMOSTAT (RANGE 0° - 110°F)								
----	----	03964402	M4375T2RPi	220	630	2150	2.9	410
----	----	03964502	M4310T2RPi	220	840	2869	3.8	410
----	----	03964602	M4315T2RPi	220	1260	4300	5.7	410
----	----	03964702	M4320T2RPi	220	1680	5733	7.6	410
Standard Models - SINGLE POLE INBUILT THERMOSTAT (RANGE 0° - 110°F)								
03277902	E4375TRP	03278702	E4375TRPW	120	750	2560	6.25	375
03278002	E4310TRP	03278802	E4310TRPW	120	1000	3413	8.33	375
03278102	E4315TRP	03278902	E4315TRPW	120	1500	5120	12.5	375
03278202	F4320TRP	03279002	F4320TRPW	208	2000	6826	9.6	375
03278302	HF4375TRP	03279102	HF4375TRPW	240/208	750 / 562	2560 / 1920	3.1 / 2.7	375
03278402	HF4310TRP	03279202	HF4310TRPW	240/208	1000 / 750	3413 / 2560	4.2 / 3.6	375
03278502	HF4315TRP	03279302	HF4315TRPW	240/208	1500 / 1125	5120 / 3840	6.3 / 5.4	375
03278602	HF4320TRP	03279402	HF4320TRPW	240/208	2000 / 1500	6826 / 5120	8.3 / 7.2	375
NO IN-BUILT THERMOSTAT								
03279502	E4375RP	03280302	E4375RPW	120	750	2560	6.25	333
03279602	E4310RP	03280402	E4310RPW	120	1000	3413	8.33	333
03279702	E4315RP	03280502	E4315RPW	120	1500	5120	12.5	333
03279802	F4320RP	03280602	F4320RPW	208	2000	6826	9.6	333
03279902	HF4375RP	03280702	HF4375RPW	240/208	750 / 562	2560 / 1920	3.1 / 2.7	333
03280002	HF4310RP	03280802	HF4310RPW	240/208	1000 / 750	3413 / 2560	4.2 / 3.6	333
03280102	HF4315RP	03280902	HF4315RPW	240/208	1500 / 1125	5120 / 3840	6.3 / 5.4	333
03280202	HF4320RP	03281002	HF4320RPW	240/208	2000 / 1500	6826 / 5120	8.3 / 7.2	333

Accessories

IVORY		WHITE		ACCESSORY OPTIONS	WT. (LBS)	LIST		
MFG CATALOG NUMBER	MFG MODEL NUMBER	MFG CATALOG NUMBER	MFG MODEL NUMBER					
03276502	4300EX8	03284502	4300EX8W	1" SEMI RECESSING EXTENDER	2	74		
03276602	4300EX16	03284602	4300EX16W	2" SEMI RECESSING EXTENDER	3	78		
03276702	4300EX32	03284702	4300EX32W	4" SURFACE MOUNTING FRAME	4	82		
03276802	4300P	03284802	4300PW	WALL PLATE ADAPTOR (OD 21.5" x 12.25")	1	57		
FIELD INSTALLED THERMOSTATS				03297702	43T	SINGLE POLE THERMOSTAT 0° - 110° F	1	78
				03297802	43T2	DOUBLE POLE THERMOSTAT 0° - 110° F	1	87

4800 Series Register Style Fan Forced Wall Heater - With Wall Box



⚠ WARNING: This product can expose you to chemicals including nickel which is known to the State of California to cause cancer, and chromium, which is known to the State of California to cause birth defects and/or reproductive harm. For more information go to www.P65Warnings.ca.gov.



Features

- Units have white powder coat finish
- Powder coated 20 gauge steel front
- Manual reset thermal limit
- Finned tubular steel element
- Propeller style fan blade - 2200 RPM / 70 CFM.
- Rough in dimensions: 14 1/2" wide x 7 1/8" high x 3 1/2" deep
- Grill dimensions: 16 3/4" Wide x 7 5/8" High
- Unit not approved for ceiling mount applications
- Left discharge only / weight: 9 lbs
- Made in U.S.A.

Standard Models

MFG CATALOG NUMBER	MFG MODEL NUMBER	VOLTS	WATTS	MAX BTUs	AMPS	LIST
DOUBLE POLE IN-BUILT THERMOSTAT (40° - 130° F TEMPERATURE RANGE)						
03281502	F4820T2RPW	208	2000	6826	9.6	433
03281602	HF4875T2RPW	240/208	750 / 562	2560 / 1920	3.1 / 2.7	433
03281702	HF4810T2RPW	240/208	1000 / 750	3413 / 2560	4.2 / 3.6	433
03281802	HF4815T2RPW	240/208	1500 / 1125	5120 / 3840	6.3 / 5.4	433
03281902	HF4820T2RPW	240/208	2000 / 1500	6826 / 5120	8.3 / 7.2	433
SINGLE POLE IN-BUILT THERMOSTAT (0° - 110° F TEMPERATURE RANGE)						
03282002	E4875TRPW	120	750	2560	6.25	406
03282102	E4810TRPW	120	1000	3413	8.33	406
03282202	E4815TRPW	120	1500	5120	12.5	406
03282302	F4820TRPW	208	2000	6826	9.6	406
NO IN-BUILT THERMOSTAT						
03282402	E4875RPW	120	750	2560	6.25	370
03282502	E4810RPW	120	1000	3413	8.33	370
03282602	E4815RPW	120	1500	5120	12.5	370
03282702	F4820RPW	208	2000	6826	9.6	370
03282802	HF4875RPW	240/208	750 / 562	2560 / 1920	3.1 / 2.7	370
03282902	HF4810RPW	240/208	1000 / 750	3413 / 2560	4.2 / 3.6	370
03283002	HF4815RPW	240/208	1500 / 1125	5120 / 3840	6.3 / 5.4	370
03283102	HF4820RPW	240/208	2000 / 1500	6826 / 5120	8.3 / 7.2	370

Accessories

MFG CATALOG NUMBER	MFG MODEL NUMBER	DESCRIPTION	WT. (LBS)	LIST
03284502	4300EX8W	1" SEMI RECESSING EXTENDER	2	74
03284602	4300EX16W	2" SEMI RECESSING EXTENDER	3	78
03284702	4300EX32W	4" SURFACE MOUNTING FRAME	4	82
03284802	4300PW	WALL PLATE ADAPTOR (OD 21.5" x 12.25")	1	57
03297702	43T	SINGLE POLE THERMOSTAT 0° - 110° F	1	78
03297902	48T2	DOUBLE POLE THERMOSTAT 40° - 130° F	1	83

Draft Barrier Heaters - General Product Information

All draft barrier heaters, unless otherwise noted, are build to order items. Consult factory for lead times. Additional charges may be incurred if changes are made after production has begun - consult factory.

Electric draft barrier heaters are an ideal supplemental heat source designed to fit under large windows and combat cold air drafts where heat loss is most predominant.

Heaters can be wall or floor mounted, or recessed. Ideal installation locations are in industrial or commercial space such as:

- offices
- hallways
- lobbies or entry ways
- conference rooms
- commercial buildings or anywhere with floor to ceiling windows



Electric Draft Barrier Features

- "UNI-LOCK" construction allows snap-fit, 2 piece installation
- Heavy Gauge Aluminum Extruded enclosures, 6063 heat treated to T-5 hardness
- DBT/DBF & RDBT-PD-12 gauge front & back
- ASHDB Series is 16 gauge Steel Front with 18 Steel gauge back ¼" pencil proof discharge louvers
- Thermal protection by full length linear limits
- Multiple heaters, factory wired on same back plate, available in up to 10' lengths
- Totally enclosed junction boxes
- Custom colors and finishes available (see chart)

DIGIT	EXAMPLE	MFG MODEL NUMBER DESIGNATION - "ASI" DRAFT BARRIER
DIGIT 1=	DBT	Series Model Number (DBT/DBF, etc.)
DIGIT 2=	PD	Use if Pedestals are Required* 2' to 5' Heaters require 2 pedestals 6' to 8' Heaters require 3 pedestals 9' & 10' Heaters require 4 pedestals
DIGIT 3=	4	Heated Length of Heater (for extended enclosure, specify amount of required enclosure on order write up, IE: 4' Heated length with 2'6" of extended enclosure
DIGIT 4=	250	Wattage per Linera foot (may not exceed allowable wattages on specific models, refer to catalog page to verify maximum WPF)
DIGIT 5=	ITS (etc)	Control Options: Refer to list price chart for available options (Verify on each model which options may be factory installed)

NOTE:

- Extended enclosures and Blank Sections are NOT punched. When a Control Section is specified, ALWAYS allow for an extended enclosure to compensate for the 6" or 12" length of the Section required.
- Note on order when finished backs are required and add list adder to model list.
- Total heater amperage must not exceed the 25 Amp rating of the high temperature limit at any voltage or wattage. This applies to all Sill Line Model Series.

COMPLETED EXAMPLE: DBT-PD-4250-ITS

NOTE: SEE 9100 AND 9300 SERIES PAGES FOR THEIR MODEL CONFIGURATION.

Voltage & Wattage Specification

VOLTAGE	STANDARD WATTAGES PER FOOT	HEATER LENGTHS
120-277	100, 125, 150, 165, 187, 200, 250*, 300, 333*, 375*	2' through 10'

* Units with extended enclosures may require more pedestals than standard length, must verify length of heater after extended enclosures for total amount of pedestals.

NOTE: All bottom inlet units must be mounted a minimum of 3 inches above finished floor.
NOTE: All dual ASHDB models have single phase elements.

Draft Barrier Heaters - General Product Information

Control Options

SUFFIX DESIGNATION	DESCRIPTION	LIST ADDER
CS 6	6" control section / will contain up to 2 control options	84
CS 12	12" control section / will contain up to 3 control options	84
ITS	Single pole, 25 Amp integral thermostat, 120,208,240 & 277 Volts	122
ITD	Double pole, 25 Amp integral thermostat, 120,208,240 & 277 Volts	131
IDS	Double pole disconnect, 20 Amp, 120, 208, 240 & 277 Volts	122
IDS 30	30 Amp disconnect (9300 Series)	162
IDS 40	40 Amp disconnect (9300 Series)	162
LVTR	Low voltage controls (trans & relay) (9300 Series)	343
PR 120-277/24	Power relay, 18 Amp tested Must specify coil voltage single pole	162
PR 120-277/120		162
PR 120-277/240		162
ATR*	Single pole, rated 25 Amps, 120 to 240 Volts, Contacts rated up to 277 Volts (must specify) Coils are 24 Volt; 24 Volt transformer	517

CUSTOM PAINT COLORS		
Durable Powder Coat Paint Finish		
COLOR	SIZE	LIST
Bankers Bronze (standard)		---
Eggshell White	Under 100 feet	5%
Black		
Gray		
Beige		
Simulated Bronze or Clear Anodized		
Special Colors 5 lb Increment - CONSULT FACTORY		

Note: Please refer to each model to verify how many controls may be integrally mounted, Control sections will add length to the heater. Must use control section with PR 240/24, PR 208/24, 208/208 and ATR

Note: If using line voltage thermostat on single phase heaters you cannot exceed 25 Amps due to Amp rating of thermostat. 347, 480, and 600V models can use up to 30 Amps with in-built thermostat.

WARNING: This product can expose you to chemicals including nickel which is known to the State of California to cause cancer, and chromium, which is known to the State of California to cause birth defects and/or reproductive harm. For more information go to www.P65Warnings.ca.gov.

9100 Series - Radius Front Draft Barrier Heater

ETL listed up to 250 Watts / foot for industrial, commercial, or residential applications



WARNING: This product can expose you to chemicals including nickel which is known to the State of California to cause cancer, and chromium, which is known to the State of California to cause birth defects and/or reproductive harm. For more information go to www.P65Warnings.ca.gov.

Features

- Standard color: Bankers Bronze
- "UNI-LOCK" construction allows snap-fit, 2 piece installation
- Units can be controlled by optional In-Built thermostat or can be constructed with relays and / or transformers for low voltage or line voltage wall thermostats
- Thermal protection by full length manual reset linear limits
- Optional duplex receptacle section
- Wiring junction boxes on each end of the unit
- Custom colors and finishes available (consult factory)
- Limited by max Amp draw of 25 Amps (with no controls)
- Additional charges may be incurred if changes are made after production has begun - consult factory
- Made in U.S.A.

HOW TO DESIGNATE A MODEL:

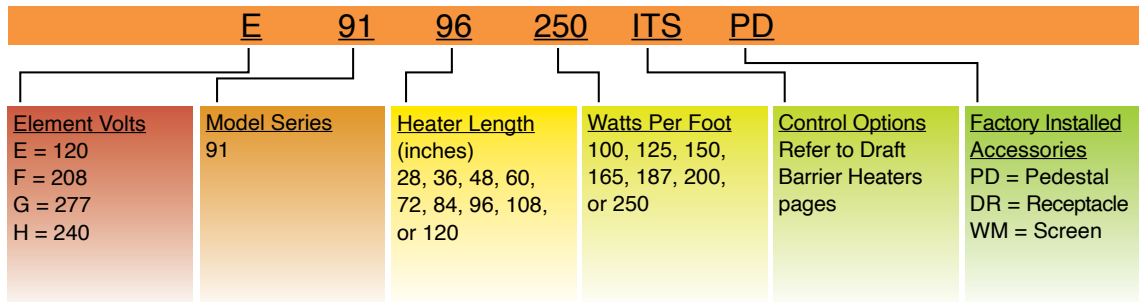

Note: For control option pricing see chart above.

Product Description

TECHNICAL INFORMATION	
AIR INTAKE	bottom
AIR DISCHARGE	Top
MIN MOUNTING HEIGHT	3"
MAX WATTS / FOOT	250
MAX ALLOWABLE AMPS	25 Amps (16 Amps with disconnect)
VOLTAGE / PHASE	120V/208V/240V/277V single phase

TECHNICAL INFORMATION	
HEIGHT	4 ½"
DEPTH	3 ⅝"
LENGTH	28" to 120" in 1' increments
CABINET MATERIAL	Aluminum
MATERIAL GAUGE	14
OPTIONAL CONTROLS THAT CAN BE BUILT INTO UNIT	Thermostat and disconnect switch (control section required for relays)

Factory Installed Accessories

SUFFIX	DESCRIPTION	LIST
DR	Duplex Receptacle in 4" Extended Enclosure (not available with 120" heater)	321
PD	28" through 60" - 2 Required	214
	72" through 96" - 3 Required	318
	108" through 120" - 4 Required	423
WM	¼" wire mesh under grill	12

Field Installed Accessories

MFG MODEL	DESCRIPTION	LIST
9100ICS	Inside Corner Section 90° or 135°	306
9100OCS	Outside Corner Section 90° or 135°	306
9100EC	Right or Left End Cap	100
9100SP	Splice Plate	75

Standard Models

	MFG MODEL	UNIT LENGTH	LIST	FINISHED BACK ADDER
Heater	9128	28"	499	69
	9136	36"	575	81
	9148	48"	660	84
	9160	60"	770	94
	9172	72"	876	101
	9184	84"	1008	120
	9196	96"	1104	130
	91108	108"	1215	150
	91120	120"	1332	167

	MFG MODEL	UNIT LENGTH	LIST	FINISHED BACK ADDER
Blank Section	91BS012	12"	140	58
	91BS024	24"	187	69
	91BS036	36"	242	81
	91BS048	48"	293	84
	91BS060	60"	343	94
	91BS072	72"	397	101
	91BS084	84"	483	120
	91BS096	96"	499	130
	91BS108	108"	552	150
	91BS120	120"	604	167

Note: All models are suitable for International use
Note: Extended enclosure per foot is \$36

CABINET

9100 Series shall be constructed of 14 gauge extruded 6063 Aluminum heat treated to T5 hardness. The uni-lock construction shall allow easy installation and access to back plate for wiring. The snap-fit front cover makes installation and service very simple. Custom factory enclosures to $\frac{1}{16}$ inch increments are built for exact wall to wall fit up to 10 foot enclosure lengths. The 14 gauge back plate will have electrical knockouts for incoming power on each end adjacent to junction box. Pedestal mounted units will have incoming power connection through the pedestal on bottom of unit and will have smooth back for optional finished back. The die punched front cover will have no screw heads or fasteners.

ELEMENTS

High mass sheathed element construction with Nickel-Chromium resistance wire embedded in compacted efficient die-electric to ensure proper heat transfer. Aluminum fins mechanically bonded to stainless steel tube allows for increased surface area and even heat transfer.

LIMIT CONTROLS

Manual reset hydraulic thermal overload covers full length of heating element and shuts down heater when safe operating temperatures are exceeded.

WIRING

Wiring shall be in either end of the enclosure. Wiring can be in the junction box or optional control section if additional controls are needed. Pedestal mounted units shall have $1\frac{1}{4}$ " hole through the pedestal and in the bottom of the enclosure for incoming power wiring. All heaters have a factory supplied built in raceway for wiring from either end of the heater or for wiring of continuous heater connections.

CONTROLS

Optional controls include single or double pole thermostat and disconnect switch that are factory wired in enclosed junction box on each end of heater enclosure. Relay, transformer relay and duplex receptacle options shall be mounted in extended length control section. Control section will add to heater enclosure length. The control section for the duplex receptacle will add 4" to enclosure length. The control section for other optional components or combinations of components will have two options (6" or 12") depending on controls required.

APPLICATION

The 9100 series is ETL listed for commercial, industrial or residential applications on all units up to 250 Watts per foot.

Product Dimensions

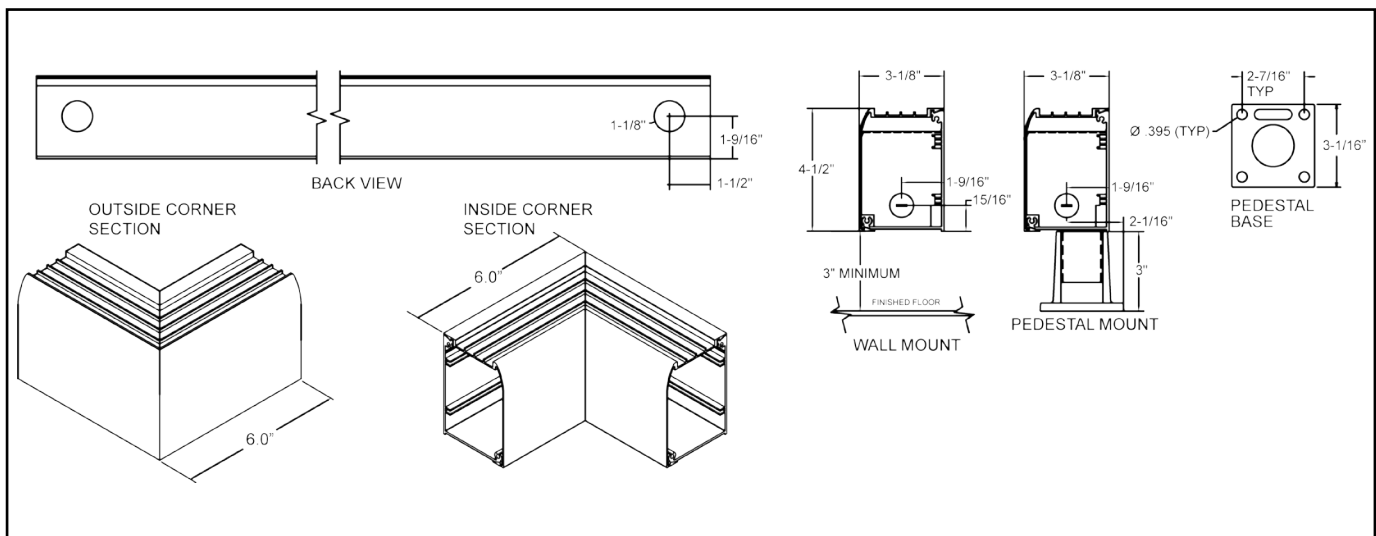

9300 Series - Radius Front Draft Barrier Heater



ETL listed up to 750 Watts/foot for industrial or commercial applications.



WARNING: This product can expose you to chemicals including nickel which is known to the State of California to cause cancer, and chromium, which is known to the State of California to cause birth defects and/or reproductive harm. For more information go to www.P65Warnings.ca.gov.

Not suitable for residential applications.

Features

- LEED and green compliance, 1 and 3 phase applications
- Industrial or commercial applications
- Standard color: Bankers Bronze (powder coated)
- Also available in other standard TPI colors and custom colors for an additional charge
- Uni-lock construction for snap fit 2 piece installation
- Temperature control can be in-built or wall mounted
- Thermal protection by full length manual reset linear limits
- Optional accessories include: duplex receptacle, and inside or outside corner sections for wall to wall custom fit.
- Additional charges may be incurred if changes are made after production has begun - consult factory.
- Made in U.S.A.

HOW TO DESIGNATE A MODEL:

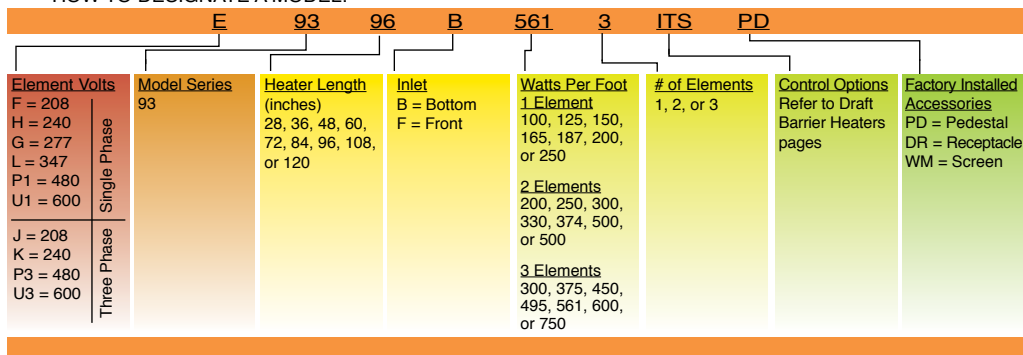

Note: 480V single phase units minimum 36" heated length; 600V single phase units minimum 48" heated length 347-480-600 single phase and all three phase units are built with low voltage option factory installed / For control option pricing see page 58

Product Description

TECHNICAL INFORMATION	
Air Intake	Bottom / Front
Air Discharge	Top
Min Mounting Height	3" for bottom intake / 0" for front intake
Max Watts / Foot	750
Max Allowable Amps	25 without relay, 40 with relay
Voltage / Phase	208V/240V/277V/347V,480V,600V Single Phase
	208V,240V,480V,600V Three Phase

TECHNICAL INFORMATION	
Height	7.5"
Depth	6.15"
Length	28" to 120" in 1' increments
Cabinet Material	Aluminum
Material Gauge	12
Optional Controls That Can Be Built Into Unit	Thermostat, Disconnect Switch, Transformer (some configurations may require control section)

Standard Models

MFG MODEL	UNIT LENGTH	LIST	FINISHED BACK ADDER
9328	28"	1296	103
9336	36"	1363	115
9348	48"	1537	122
9360	60"	1709	130
9372	72"	1831	137
9384	84"	1959	147
9396	96"	2066	156
93108	108"	2166	162
93120	120"	2305	173

MFG MODEL	UNIT LENGTH	LIST	FINISHED BACK ADDER
93BS012	12"	532	96
93BS024	24"	625	103
93BS036	36"	702	115
93BS048	48"	811	122
93BS060	60"	906	130
93BS072	72"	981	137
93BS084	84"	1075	147
93BS096	96"	1169	156
93BS108	108"	1265	162
93BS120	120"	1355	173

Factory Installed Accessories

SUFFIX	DESCRIPTION	LIST
DR	Duplex Receptacle in 4.5" Extended Enclosure (not available with 120" heater)	239
PD	28" through 60" - 2 Required	224
	72" through 96" - 3 Required	336
	108" through 120" - 4 Required	448
WM	1/4" wire mesh under grill	\$16/ FT
IDS30	30 Amp/240V Disconnect Switch	162
IDS40	40 Amp/600V Disconnect Switch	162

Note: If using line voltage thermostat on 1 phase heaters, you cannot exceed 25 Amps due to Amp rating of thermostat. 347, 480, and 600V can use 30 Amps with in-built thermostat.

Field Installed Accessories

MFG MODEL	DESCRIPTION	LIST
9300ICS	Inside Corner Section 90° or 135°	363
9300OCS	Outside Corner Section 90° or 135°	363
9300EC	Right or Left End Cap	140
9300SP	Splice Plate	75

Note: All models are suitable for International use

Note: Extended enclosure per foot is \$103.

CABINET

9300 Series shall be constructed of 12 gauge extruded 6063 Aluminum heat treated to T5 hardness. The uni-lock construction shall allow easy installation and access to back plate for wiring. The snap-fit front cover makes installation and service very simple. Custom factory enclosures to $\frac{1}{16}$ inch increments are built for exact wall to wall fit up to 10 foot enclosure lengths. The 12 gauge back plate will have electrical knockouts for incoming power on each end adjacent to junction box. Pedestal mounted units will have incoming power connection through the pedestal on bottom of unit and will have smooth back for optional finished back. The die punched front cover will have no screw heads or fasteners.

ELEMENTS

High mass sheathed element construction with Nickel-Chromium resistance wire embedded in compacted efficient dielectric to ensure proper heat transfer. Aluminum fins mechanically bonded to stainless steel tube allows for increased surface area and even heat transfer.

LIMIT CONTROLS

Manual reset hydraulic thermal overload covers full length of heating element and shuts down heater when safe operating temperatures are exceeded.

WIRING

Wiring shall be in either end of the enclosure. Wiring can be in the junction box or optional control section if additional controls are needed. Pedestal mounted units shall have $1\frac{1}{4}$ " hole through the pedestal and in the bottom of the enclosure for incoming power wiring. All heaters have a factory supplied built in raceway for wiring from either end of the heater or for wiring of continuous heater connections.

CONTROLS

Optional controls include single or double pole thermostat and disconnect switch that are factory wired in enclosed junction box on each end of heater enclosure. **If necessary, control section will add to heater enclosure length.** The control section for other optional components or combinations of components will have two options (6" or 12") depending on controls required.

APPLICATION

The 9300 series is ETL listed for commercial or industrial applications on all units up to 750 Watts per foot. 3 phase units have a minimum of 300 Watts per foot. 3 phase units require three elements.

Product Dimensions

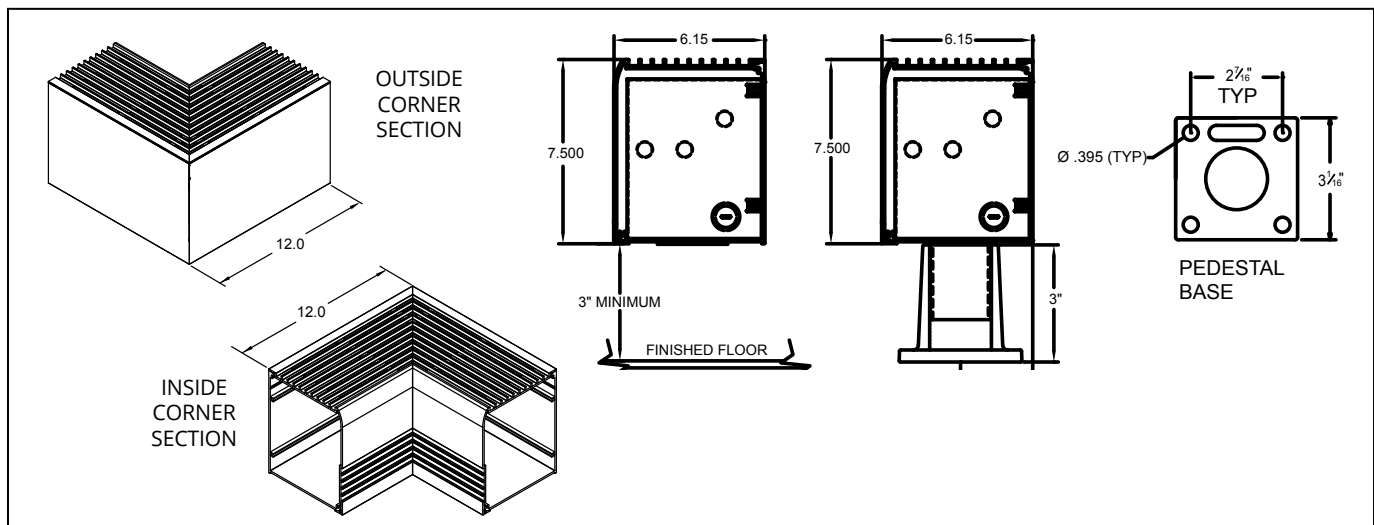

DBF/DBT Series - Draft Barrier Heater

DBT Series

DBF Series

Cabinet dimensions:
3 1/2" x 6" x 10' maximum length
Made in U.S.A.

DBT Series
Wall mount model
300 WPF Max.

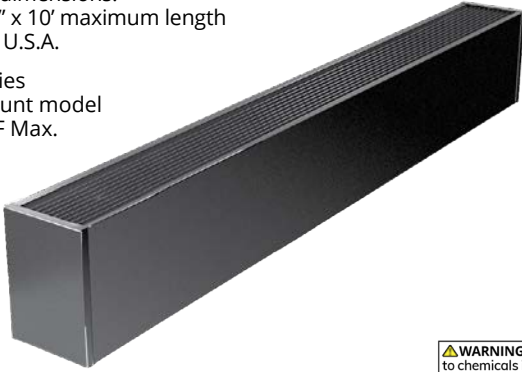

DBF Floor Mount Model
250 WPF Max.

⚠ WARNING: This product can expose you to chemicals including nickel which is known to the State of California to cause cancer, and chromium, which is known to the State of California to cause birth defects and/or reproductive harm. For more information go to www.P65Warnings.ca.gov.

**Not suitable for residential applications.
Built to order: consult factory for lead time.**

MFG MODEL NUMBER	LENGTH	LIST PAINTED BRONZE	
		HEATER	FINISHED BACK ADDER
DBF-2/DBT-2	2'	558	72
DBF-3/DBT-3	3'	660	96
DBF-4/DBT-4	4'	773	88
DBF-5/DBT-5	5'	908	100
DBF-6/DBT-6	6'	1110	108
DBF-7/DBT-7	7'	1238	103
DBF-8/DBT-8	8'	1370	136
DBF-9/DBT-9	9'	1512	156
DBF-10/DBT-10	10'	1635	171
Extended enclosure per foot		83	
BLANK SECTION			
DBF/DBT-100BS	1'	166	63
DBF/DBT-200BS	2'	249	72
DBF/DBT-300BS	3'	326	82
DBF/DBT-400BS	4'	404	87
DBF/DBT-500BS	5'	782	100
DBF/DBT-600BS	6'	559	107
DBF/DBT-700BS	7'	650	130
DBF/DBT-800BS	8'	736	136
DBF/DBT-900BS	9'	819	156
DBF/DBT-1000BS	10'	947	171

ACCESSORIES DESCRIPTION	LIST PAINTED BRONZE
DBF/DBT IC / Inside Corner Section - 90 - 180°	304
DBF/DBT OC / Outside Corner Section - 180 - 270 Degrees - 6" longest side	
DBF/DBT ECR / Right Hand End Cap - DBF/DBT ECL / Left Hand End Cap	107
DBF/DBT IECR / Inside Fitting Right End Cap - DBF/DBT IECL / Inside Fitting Left End Cap	122
DBF/DBT WT / 2" - 6" Wall Trim	75
DBF/DBT SP / 1 1/2" Splice Plate	
DBF/DBT MF / Mullion Front up to 1'	123
DBF/DBT IF / Inside Filler up to 1'	
3/4" Conduit Raceway (standard is 1/2")	\$11.00 PER FOOT
Mesh / 1/4" Wire Mesh under Grill	\$16.00 PER FOOT
Pedestals - specify 2" or 3"	\$106.00 PER PEDESTAL

See chart for required amount per heater



Cabinet Dimensions:
7" x 6" x 10' Maximum Length
Made in U.S.A.



WARNING: This product can expose you to chemicals including nickel which is known to the State of California to cause cancer, and chromium, which is known to the State of California to cause birth defects and/or reproductive harm. For more information go to www.P65Warnings.ca.gov.

NOTE:

**Not suitable for residential applications.
300 Watts per foot max
Pedestals included with unit.
Rounded enclosure with flat top discharge.
Special build: consult factory for lead time.**

MFG MODEL NUMBER	LENGTH	LIST
		PAINTED BRONZE
RDBT-PD-2	2'	932
RDBT-PD-3	3'	1100
RDBT-PD-4	4'	1297
RDBT-PD-5	5'	1508
RDBT-PD-6	6'	1745
RDBT-PD-7	7'	1971
RDBT-PD-8	8'	2197
RDBT-PD-9	9'	2424
RDBT-PD-10	10'	2687
Extended enclosure per foot		147
BLANK SECTIONS		
RDBT-PD-100BS	1'	519
RDBT-PD-200BS	2'	683
RDBT-PD-300BS	3'	860
RDBT-PD-400BS	4'	1036
RDBT-PD-500BS	5'	1212
RDBT-PD-600BS	6'	1392
RDBT-PD-700BS	7'	1563
RDBT-PD-800BS	8'	1745
RDBT-PD-900BS	9'	1921
RDBT-PD-1000BS	10'	2130

ACCESSORIES DESCRIPTION	PAINTED BRONZE LIST
RDBT-PDIC / Inside Corner Section 90 - 180 Degrees	189
RDBT-PDOC / Outside Corner Section 180 - 270 Degrees - 6" longest side	189
RDBT-PDIECR/Inside Fitting Right End Cap RDBT-PDIECL/Inside Fitting Left End Cap	154
¾" Conduit Raceway (standard is ½")	\$11.00 per foot
Mesh - ¼" Wire Mesh under Grill	\$16.00 per foot

NOTE: RDBT-PD Series will permit a thermostat mounted on one side and a disconnect on the other side. More or other controls require a 6" or 12" control section. Typically, thermostats are mounted on the left side of heater. Control sections will add to length of heater.



Cabinet Dimensions: 5 1/2" x 8" thru 20" x 10' max length
 Cannot be Anodized
 Made in U.S.A.

⚠ WARNING: This product can expose you to chemicals including nickel which is known to the State of California to cause cancer, and chromium, which is known to the State of California to cause birth defects and/or reproductive harm. For more information go to www.P65Warnings.ca.gov.



Not suitable for residential applications. 500 Watts per foot maximum.
16-gauge steel enclosure, 18-gauge back plate. Heights may vary from 8" up to 20".
Bottom intake / Top discharge. Special build - consult factory for lead time.

MFG MODEL NUMBER / LENGTH	WATTS/FT.	LIST					
		8-12" HIGH		13-16" HIGH		17-20" HIGH	
		HEATER	FINISHED BACK ADDER	HEATER	FINISHED BACK ADDER	HEATER	FINISHED BACK ADDER
ASHDB-2 2'	to 250	780	84	854	129	992	162
	251-500	892	84	982	129	1116	162
ASHDB-3 3'	to 250	898	88	992	131	1173	173
	251-500	909	88	1116	131	1281	173
ASHDB-4 4'	to 250	1026	96	1129	137	1351	183
	251-500	1144	96	1552	137	1485	183
ASHDB-5 5'	to 250	1132	103	1270	146	1533	187
	251-500	1268	103	1396	146	1667	187
ASHDB-6 6'	to 250	1334	117	1444	158	1772	200
	251-500	1453	117	1577	158	1897	200
ASHDB-7 7'	to 250	1559	129	1654	162	2025	205
	251-500	1684	129	1789	162	2157	205
ASHDB-8 8'	to 250	1820	135	1913	179	2280	219
	251-500	1913	135	2044	179	2404	219
ASHDB-9 9'	to 250	2022	143	2168	186	2534	228
	251-500	2140	143	2296	186	2661	228
ASHDB-10 10'	to 250	2245	156	2424	197	2792	245
	251-500	2373	156	2556	197	2914	245
Extended enclosure per foot		88		111		133	
BLANK SECTIONS							
ASHDB-8/20-100BS 1'		247	76	297	113	313	129
ASHDB-8/20-200BS 2'		333	84	390	117	472	134
ASHDB-8/20-300BS 3'		433	88	481	143	607	137
ASHDB-8/20-400BS 4'		474	96	590	131	748	149
ASHDB-8/20-500BS 5'		563	103	689	135	889	156
ASHDB-8/20-600BS 6'		669	98	795	191	1028	167
ASHDB-8/20-700BS 7'		789	129	872	156	1207	179
ASHDB-8/20-800BS 8'		859	135	970	162	1348	191
ASHDB-8/20-900BS 9'		958	143	1097	173	1506	197
ASHDB-8/20-1000BS 10'		1056	156	1208	186	1556	245

ACCESSORIES DESCRIPTION	8-12" High	13-16" High	17-20" High
	LIST		
ASHDB IC / Inside Corner Section 90 - 180 Degrees	497	519	546
ASHDB OC / Outside Corner Section 180 - 270 Degrees - 6" longest side	497	519	546
ASHDB ECR / Right End Cap ASHDB ECL / Left End Cap	85	136	178
ASHDB SP / 1 1/2" Splice Plate	85	136	178
ASHDB WT / 2" - 6" Wall Trim	85	136	178
3/4" Conduit Raceway (standard is 1/2")	\$11.00 per foot		
Mesh / 1/4" Wire Mesh under Grill	\$16.00 per foot		
Pedestals - Specify 2" or 3"	\$106.00 per pedestal		
See chart for required amount per heater			

NOTE: ASHDB Series will permit a thermostat mounted on one side and a disconnect on the other side, more or other controls require a 6" or 12" control section. Typically, thermostats are mounted on left side of heater. Control section will add to length of heater.



Features

- Heavy-duty bar grate. Constructed of solid extruded aluminum bars with clear anodized finish
- Stainless steel element with aluminum fins
- Limit Control - Automatic reset capillary extending full length of heated section.
- Adjustable levelers to allow positioning flush with finished floor - accessible from the top of the heater
- Large wiring compartments with 3/4 inch conduit wireway allows wiring from either end
- Control sections and blank sections available
- Knockouts provided on ends and sides to allow inter-connection of heaters and accessories

Product Description

The 9900 series heaters are fixed location convection heaters intended for commercial / industrial use. The 9900 Series can be fully recessed into the floor with 'zero' clearance to combustibles or surface mounted and wrapped with a custom built enclosure on the sides and ends with 'zero' clearance. Continuous runs can be accomplished by installing heaters end to end. Blank Sections and Control Sections are available. All electrical components are factory assembled.



HOW TO DESIGNATE A MODEL:

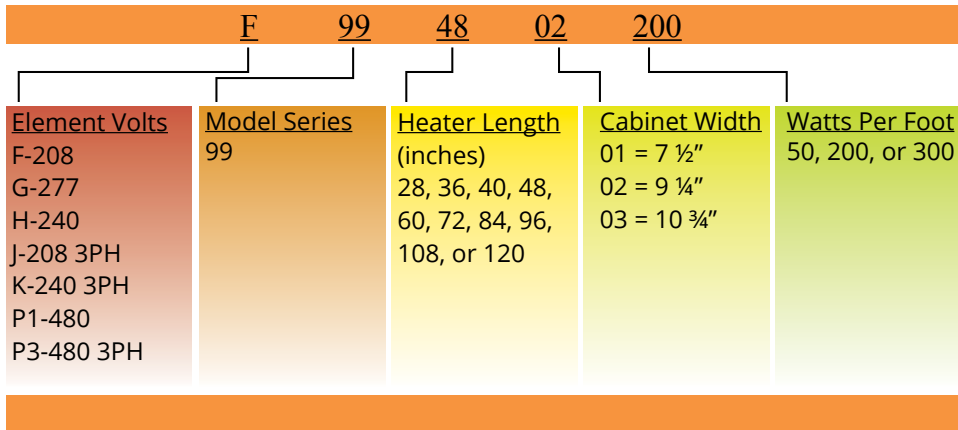

Product Dimensions

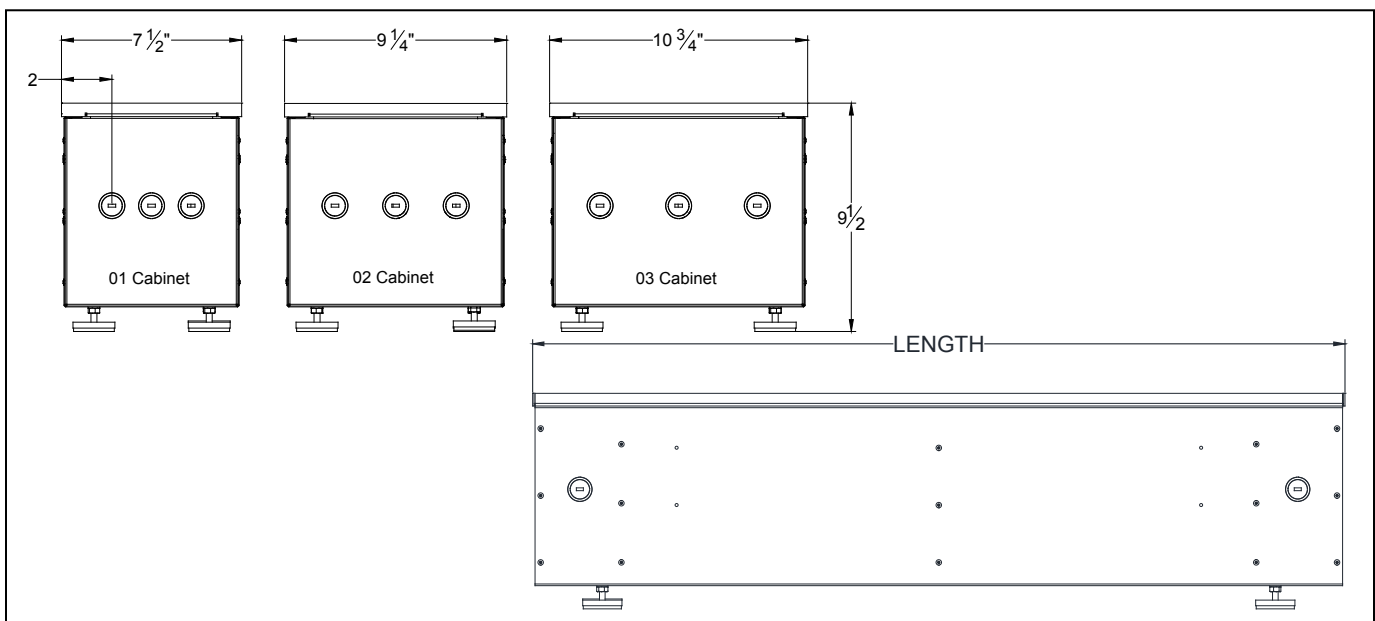

9900 Series - Commercial / Industrial Floor Heater

Product Specifications

CABINET

01 Cabinet Width: 1 element, available with 150 or 200 watts/foot maximum with the exception of the 28" model, maximum wattage for the 28"* unit is 300 watts. single phase voltages only

02 Cabinet Width: 2 elements, available with 200 or 300 watts/foot maximum with the exception of the 28" model, maximum wattage for the 28"* unit is 400 watts. single phase voltages only.

03 Cabinet Width: 3 elements, available 300 watts/foot maximum with the exception of the 28" model, maximum wattage for the 28"* unit is 400 watts. single and three phase voltages

Note: Design limitations affect certain 28 inch models. Contact factory for availability.

CONTROLS

Relays and transformers available for all voltages. ATR available for 208,240 and 277 single phase only.

Standard Models

MFG CATALOG NUMBER	MFG MODEL NUMBER	VOLTS	LENGTH	WATTS	AMPS	LIST	MFG CATALOG NUMBER	MFG MODEL NUMBER	VOLTS	LENGTH	WATTS	AMPS	LIST
05666402	F9928-01-86	208	28"	200	.96	1648	05680302	F9948-03-200	208	48"	800	3.85	2746
05667302	F9928-01-129	208	28"	300	1.44	1648	05674402	F9948-02-300	208	48"	1200	5.77	2840
05680102	F9928-03-129	208	28"	300	1.44	2011	05681202	F9948-03-300	208	48"	1200	5.77	2746
05674202	F9928-02-172	208	28"	400	1.92	1936	05668402	H9948-01-150	240	48"	600	2.5	2236
05681002	F9928-03-172	208	28"	400	1.92	2011	05669302	H9948-01-200	240	48"	800	3.33	2236
05668202	H9928-01-86	240	28"	200	.83	1648	05675202	H9948-02-200	240	48"	800	3.33	2840
05669102	H9928-01-129	240	28"	300	1.25	1648	05682102	H9948-03-200	240	48"	800	3.33	2746
05681902	H9928-03-129	240	28"	300	1.25	2011	05676102	H9948-02-300	240	48"	1200	5.00	2840
05675902	H9928-02-172	240	28"	400	1.67	1936	05683002	H9948-03-300	240	48"	1200	5.00	2746
05682802	H9928-03-172	240	28"	400	1.67	2011	05670202	G9948-01-150	277	48"	600	2.17	2236
05670002	G9928-01-86	277	28"	200	.72	1648	05671102	G9948-01-200	277	48"	800	2.89	2236
05670902	G9928-01-129	277	28"	600	2.17	1648	05676902	G9948-02-200	277	48"	800	2.89	2840
05677602	G9928-02-172	277	28"	400	1.44	1936	05683802	G9948-03-200	277	48"	800	2.88	2746
05684502	G9928-03-172	277	28"	400	1.44	2011	05677802	G9948-02-300	277	48"	1200	4.33	2840
05666502	F9936-01-150	208	36"	450	2.16	2021	05684702	G9948-03-300	277	48"	1200	4.33	2746
05667402	F9936-01-200	208	36"	600	2.88	2021	05671902	P9948-01-150	480	48"	600	1.25	2236
05673402	F9936-02-200	208	36"	600	2.88	1948	05672702	P9948-01-200	480	48"	800	1.67	2236
05680202	F9936-03-200	208	36"	600	2.88	2270	05678602	P9948-02-200	480	48"	800	1.67	2840
05674302	F9936-02-300	208	36"	900	4.33	1948	05679402	P9948-02-300	480	48"	1200	2.50	2840
05681102	F9936-03-300	208	36"	900	4.33	2270	05685502	P9948-03-300	480	48"	1200	2.50	2746
05668302	H9936-01-150	240	36"	450	1.88	2021	05666702	F9960-01-150	208	60"	750	3.6	3086
05669202	H9936-01-200	240	36"	600	2.5	2021	05667602	F9960-01-200	208	60"	1000	4.81	3086
05675102	H9936-02-200	240	36"	600	2.50	1948	05673602	F9960-02-200	208	60"	1000	4.81	3600
05682002	H9936-03-200	240	36"	600	2.50	2270	05680402	F9960-03-200	208	60"	1000	4.81	3435
05676002	H9936-02-300	240	36"	900	3.75	1948	05674502	F9960-02-300	208	60"	1500	7.21	3600
05682902	H9936-03-300	240	36"	900	3.75	2270	05681302	F9960-03-300	208	60"	1500	7.21	3435
05670102	G9936-01-150	277	36"	450	1.62	2021	05668502	H9960-01-150	240	60"	750	3.13	3086
05671002	G9936-01-200	277	36"	600	2.17	2021	05669402	H9960-01-200	240	60"	1000	4.17	3086
05676802	G9936-02-200	277	36"	600	2.17	1948	05675302	H9960-02-200	240	60"	1000	4.17	3600
05683702	G9936-03-200	277	36"	600	2.16	2270	05682202	H9960-03-200	240	60"	1000	4.17	3435
05677702	G9936-02-300	277	36"	900	3.25	1948	05676202	H9960-02-300	240	60"	1500	6.25	3600
05684602	G9936-03-300	277	36"	900	3.25	2270	05683102	H9960-03-300	240	60"	1500	6.25	3435
05671802	P9936-01-150	480	36"	450	0.94	2021	05670302	G9960-01-150	277	60"	750	2.70	3086
05672602	P9936-01-200	480	36"	600	1.25	2021	05671202	G9960-01-200	277	60"	1000	3.61	3086
05678502	P9936-02-200	480	36"	600	1.25	1948	05677002	G9960-02-200	277	60"	1000	3.61	3600
05679302	P9936-02-300	480	36"	900	1.88	1948	05683902	G9960-03-200	277	60"	1000	3.61	3435
05685402	P9936-03-300	480	36"	900	1.875	2270	05677902	G9960-02-300	277	60"	1500	5.42	3600
05666602	F9948-01-150	208	48"	600	2.88	2236	05684802	G9960-03-300	277	60"	1500	5.42	3435
05667502	F9948-01-200	208	48"	800	3.85	2236	05672002	P9960-01-150	480	60"	750	1.56	3086
05673502	F9948-02-200	208	48"	800	3.85	2840	05672802	P9960-01-200	480	60"	1000	2.08	3086

9900 Series - Commercial / Industrial Floor Heater

Standard Models

MFG CATALOG NUMBER	MFG MODEL NUMBER	VOLTS	LENGTH	WATTS	AMPS	LIST	MFG CATALOG NUMBER	MFG MODEL NUMBER	VOLTS	LENGTH	WATTS	AMPS	LIST
05678702	P9960-02-200	480	60"	1000	2.1	3600	05667002	F9996-01-150	208	96"	1200	5.77	4542
05679502	P9960-02-300	480	60"	1500	3.13	3600	05667902	F9996-01-200	208	96"	1600	7.69	4542
05685602	P9960-03-300	480	60"	1500	3.13	3435	05673902	F9996-02-200	208	96"	1600	7.69	5323
05666802	F9972-01-150	208	72"	900	4.33	3588	05680702	F9996-03-200	208	96"	1600	7.69	5039
05667702	F9972-01-200	208	72"	1200	5.77	3588	05674802	F9996-02-300	208	96"	2400	11.54	5323
05673702	F9972-02-200	208	72"	1200	5.77	4121	05681602	F9996-03-300	208	96"	2400	11.54	5039
05680502	F9972-03-200	208	72"	1200	5.77	3975	05668802	H9996-01-150	240	96"	1200	5.0	4542
05674602	F9972-02-300	208	72"	1800	8.65	3975	05669702	H9996-01-200	240	96"	1600	6.67	4542
05681402	F9972-03-300	208	72"	1800	8.65	3975	05675602	H9996-02-200	240	96"	1600	6.67	5323
05668602	H9972-01-150	240	72"	900	3.75	3588	05682502	H9996-03-200	240	96"	1600	6.67	5039
05669502	H9972-01-200	240	72"	1200	5.00	3588	05676502	H9996-02-300	240	96"	2400	10.0	5323
05675402	H9972-02-200	240	72"	1200	5.00	4121	05683402	H9996-03-300	240	96"	2400	10.0	5039
05682302	H9972-03-200	240	72"	1200	5.00	3975	05670602	G9996-01-150	277	96"	1200	4.33	4542
05676302	H9972-02-300	240	72"	1800	7.50	4121	05671502	G9996-01-200	277	96"	1600	5.78	4542
05683202	H9972-03-300	240	72"	1800	7.50	3975	05677302	G9996-02-200	277	96"	1600	5.78	5323
05670402	G9972-01-150	277	72"	900	3.25	3588	05684202	G9996-03-200	277	96"	1600	5.78	5039
05671302	G9972-01-200	277	72"	1200	4.33	3588	05678202	G9996-02-300	277	96"	2400	8.66	5323
05677102	G9972-02-200	277	72"	1200	4.33	4121	05685102	G9996-03-300	277	96"	2400	8.66	5039
05684002	G9972-03-200	277	72"	1200	4.33	3975	05672302	P9996-01-150	480	96"	1200	2.50	4542
05678002	G9972-02-300	277	72"	1800	6.50	4121	05673102	P9996-01-200	480	96"	1600	3.33	4542
05684902	G9972-03-300	277	72"	1800	6.5	3975	05679002	P9996-02-200	480	96"	1600	3.33	5323
05672102	P9972-01-150	480	72"	900	1.88	3588	05679802	P9996-02-300	480	96"	2400	5.00	5323
05672902	P9972-01-200	480	72"	1200	2.50	3588	05685902	P9996-03-300	480	96"	2400	5.00	5039
05678802	P9972-02-200	480	72"	1200	2.50	4121	05667102	F99108-01-150	208	108"	1350	6.49	4815
05679602	P9972-02-300	480	72"	1800	3.75	4121	05668002	F99108-01-200	208	108"	1800	8.65	4815
05685702	P9972-03-300	480	72"	1800	3.75	3975	05674002	F99108-02-200	208	108"	1800	8.65	5620
05666902	F9984-01-150	208	84"	1050	5.05	4049	05680802	F99108-03-200	208	108"	1800	8.65	5321
05667802	F9984-01-200	208	84"	1400	6.73	4049	05674902	F99108-02-300	208	108"	2700	13.0	5620
05673802	F9984-02-200	208	84"	1400	6.73	4704	05681702	F99108-03-300	208	108"	2700	13.0	5321
05680602	F9984-03-200	208	84"	1400	6.73	4467	05668902	H99108-01-150	240	108"	1350	5.63	4815
05674702	F9984-02-300	208	84"	2100	10.1	4704	05669802	H99108-01-200	240	108"	1800	7.50	4815
05681502	F9984-03-300	208	84"	2100	10.1	4467	05675702	H99108-02-200	240	108"	1800	7.50	5620
05668702	H9984-01-150	240	84"	1050	4.38	4049	05682602	H99108-03-200	240	108"	1800	7.50	5321
05669602	H9984-01-200	240	84"	1400	5.83	4049	05676602	H99108-02-300	240	108"	2700	11.25	5620
05675502	H9984-02-200	240	84"	1400	5.83	4704	05683502	H99108-03-300	240	108"	2700	11.25	5321
05682402	H9984-03-200	240	84"	1400	5.83	4467	05670702	G99108-01-150	277	108"	1350	4.87	4815
05676402	H9984-02-300	240	84"	2100	8.75	4704	05671602	G99108-01-200	277	108"	1800	6.49	4815
05683302	H9984-03-300	240	84"	2100	8.75	4467	05677402	G99108-02-200	277	108"	1800	6.50	5620
05670502	G9984-01-150	277	84"	1050	3.79	4049	05684302	G99108-03-200	277	108"	1800	6.5	5321
05671402	G9984-01-200	277	84"	1400	5.05	4049	05678302	G99108-02-300	277	108"	2700	9.75	5620
05677202	G9984-02-200	277	84"	1400	5.05	4704	05685202	G99108-03-300	277	108"	2700	9.75	5321
05684102	G9984-03-200	277	84"	1400	5.1	4467	05672402	P99108-01-150	480	108"	1350	2.81	4815
05678102	G9984-02-300	277	84"	2100	7.58	4704	05673202	P99108-01-200	480	108"	1800	3.75	4815
05685002	G9984-03-300	277	84"	2100	7.58	4467	05679102	P99108-02-200	480	108"	1800	3.75	5620
05672202	P9984-01-150	480	84"	1050	2.19	4049	05679902	P99108-02-300	480	108"	2700	5.63	5620
05673002	P9984-01-200	480	84"	1400	2.92	4049	05686002	P99108-03-300	480	108"	2700	5.63	5321
05678902	P9984-02-200	480	84"	1400	2.92	4704							
05679702	P9984-02-300	480	84"	2100	4.4	4704							
05685802	P9984-03-300	480	84"	2100	4.38	4467							

9900 Series - Commercial / Industrial Floor Heater

Standard Models

MFG CATALOG NUMBER	MFG MODEL NUMBER	VOLTS	LENGTH	WATTS	AMPS	LIST
05667202	F99120-01-150	208	120"	1500	7.21	5264
05668102	F99120-01-200	208	120"	2000	9.62	5264
05674102	F99120-02-200	208	120"	2000	9.62	6108
05680902	F99120-03-200	208	120"	2000	9.62	5799
05675002	F99120-02-300	208	120"	3000	14.42	6108
05681802	F99120-03-300	208	120"	3000	14.42	5799
05669002	H99120-01-150	240	120"	1500	6.25	5264
05669902	H99120-01-200	240	120"	2000	8.33	5264
05675802	H99120-02-200	240	120"	2000	8.33	6108
05682702	H99120-03-200	240	120"	2000	8.33	5799
05676702	H99120-02-300	240	120"	3000	12.5	6108
05683602	H99120-03-300	240	120"	3000	12.5	5799
05670802	G99120-01-150	277	120"	1500	5.42	5264
05671702	G99120-01-200	277	120"	2000	7.22	5264
05677502	G99120-02-200	277	120"	2000	7.22	6108
05684402	G99120-03-200	277	120"	2000	7.22	5799
05678402	G99120-02-300	277	120"	3000	10.83	5799
05685302	G99120-03-300	277	120"	3000	10.83	5799
05672502	P99120-01-150	480	120"	1500	3.13	5264
05673302	P99120-01-200	480	120"	2000	4.17	5264
05679202	P99120-02-200	480	120"	2000	4.17	6108
05680002	P99120-02-300	480	120"	3000	6.25	6108
05686102	P99120-03-300	480	120"	3000	6.3	5799

3 PHASE UNITS						
MFG CATALOG NUMBER	MFG MODEL NUMBER	VOLTS	LENGTH	WATTS	AMPS	LIST
05686202	J9928-03-129	208/3	28"	300	0.83	2079
05687102	J9928-03-172	208/3	28"	400	1.11	2079
05688002	K9928-03-129	240/3	28"	300	0.72	2079
05688902	K9928-03-172	240/3	28"	400	0.96	2079
05690602	P39928-03-172	480/3	28"	400	0.48	2079
05686302	J9936-03-200	208/3	36"	600	1.67	2228
05687202	J9936-03-300	208/3	36"	900	2.50	2228
05688102	K9936-03-200	240/3	36"	600	1.45	2228
05689002	K9936-03-300	240/3	36"	900	2.2	2228
05689802	P39936-03-200	480/3	36"	600	0.72	2228
05690702	P39936-03-300	480/3	36"	900	1.1	2228
05686402	J9948-03-200	208/3	48"	800	2.22	2743
05687302	J9948-03-300	208/3	48"	1200	3.33	2743
05688202	K9948-03-200	240/3	48"	800	1.93	2743
05689102	K9948-03-300	240/3	48"	1200	2.9	2743

3 PHASE UNITS CONTINUED						
MFG CATALOG NUMBER	MFG MODEL NUMBER	VOLTS	LENGTH	WATTS	AMPS	LIST
05689902	P39948-03-200	480/3	48"	800	0.96	2743
05690802	P39948-03-300		48"	1200	1.45	2743
05686502	J9960-03-200	208/3	60"	1000	2.78	3435
05687402	J9960-03-300		60"	1500	4.17	3435
05688302	K9960-03-200	240/3	60"	1000	2.4	3435
05689202	K9960-03-300		60"	1500	3.6	3435
05690002	P39960-03-200	480/3	60"	1000	1.2	3435
05690902	P39960-03-300		60"	1500	1.8	3435
05686602	J9972-03-200	208/3	72"	1200	3.33	3994
05687502	J9972-03-300		72"	1800	5.00	3994
05688402	K9972-03-200	240/3	72"	1200	2.9	3994
05689302	K9972-03-300		72"	1800	4.3	3994
05690102	P39972-03-200	480/3	72"	1200	1.45	3994
05691002	P39972-03-300		72"	1800	2.17	3994
05686702	J9984-03-200	208/3	84"	1400	3.89	4483
05687602	J9984-03-300		84"	2100	5.83	4483
05688502	K9984-03-200	240/3	84"	1400	3.4	4483
05689402	K9984-03-300		84"	2100	5.1	4483
05690202	P39984-03-200	480/3	84"	1400	1.69	4483
05691102	P39984-03-300		84"	2100	2.5	4483
05686802	J9996-03-200	208/3	96"	1600	4.44	5055
05687702	J9996-03-300		96"	2400	6.67	5055
05688602	K9996-03-200	240/3	96"	1600	3.9	5055
05689502	K9996-03-300		96"	2400	5.8	5055
05690302	P39996-03-200	480/3	96"	1600	1.93	5055
05691202	P39996-03-300		96"	2400	2.9	5055
05686902	J99108-03-200	208/3	108"	1800	5.00	5307
05687802	J99108-03-300		108"	2700	7.50	5307
05688702	K99108-03-200	240/3	108"	1800	4.3	5307
05689602	K99108-03-300		108"	2700	6.5	5307
05690402	P399108-03-200	480/3	108"	1800	2.17	5307
05691302	P399108-03-300		108"	2700	3.25	5307
05687002	J99120-03-200	208/3	120"	2000	5.56	5805
05687902	J99120-03-300		120"	3000	8.33	5805
05688802	K99120-03-200	240/3	120"	2000	4.8	5805
05689702	K99120-03-300		120"	3000	7.2	5805
05690502	P399120-03-200	480/3	120"	2000	2.4	5805
05691402	P399120-03-300		120"	3000	3.6	5805

9900 Series - Commercial / Industrial Floor Heater

Standard Models

BLANK SECTION			
MFG MODEL NUMBER	MFG CATALOG NUMBER	LENGTH	LIST
BS9928-01	05691502	28"	1449
BS9936-01	05691602	36"	1747
BS9948-01	05691702	48"	2228
BS9960-01	05691802	60"	2825
BS9972-01	05691902	72"	3324
BS9984-01	05692002	84"	3783
BS9996-01	05692102	96"	4209
BS99108-01	05692202	108"	4478
BS99120-01	05692302	120"	4919
BS9928-02	05692402	28"	1449
BS9936-02	05692502	36"	1747
BS9948-02	05692602	48"	2228
BS9960-02	05692702	60"	2825
BS9972-02	05692802	72"	3324
BS9984-02	05692902	84"	3783
BS9996-02	05693002	96"	4209
BS99108-02	05693102	108"	4479
BS99120-02	05693202	120"	4919
BS9928-03	05693302	28"	1449
BS9936-03	05693402	36"	1747
BS9948-03	05693502	48"	2229
BS9960-03	05693602	60"	2825
BS9972-03	05693702	72"	3324
BS9984-03	05693802	84"	3783
BS9996-03	05693902	96"	4209
BS99108-03	05694002	108"	4479
BS99120-03	05694102	120"	4919

CONTROL SECTION				
MFG CATALOG NUMBER	MFG MODEL NUMBER	VOLTS	PHASE	LIST
05694202	CS99-03-PC-480V 3PH	480	3	1769
05694302	CS99-03-PC-240V 3PH	240	3	1730
05694402	CS99-03-PC-208V 3PH	208	3	1730
05694502	CS99-03-PC-480V 1PH	480	1	1577
05694602	CS99-03-PC-277V 1PH	277	1	1536
05694702	CS99-03-PC-240V 1PH	240	1	1536
05694802	CS99-03-PC-208V 1PH	208	1	1536
05694902	CS99-02-PC-480V 1PH	480	1	1620
05695002	CS99-02-PC-277V 1PH	277	1	1620
05695102	CS99-02-PC-240V 1PH	240	1	1620
05695202	CS99-02-PC-208V 1PH	208	1	1620
05695302	CS99-01-PC-480V 1PH	480	1	1549
05695402	CS99-01-PC-277V 1PH	277	1	1507
05695502	CS99-01-PC-240V 1PH	240	1	1507
05695602	CS99-01-PC-208V 1PH	208	1	1507
MFG CATALOG NUMBER	MFG MODEL NUMBER	VOLTS	AMPS	LIST
05695702	CS99-03-LVTR 480V 15A	480	15	1141
05695802	CS99-03-LVTR 277V 30A	277	30	1141
05695902	CS99-03-LVTR 240V 30A	240	30	1141
05696002	CS99-03-LVTR 208V 30A	208	30	1141
05696102	CS99-03-ATR 277V 18A	277	18	1220
05696202	CS99-03-ATR 240V 22A	240	22	1310
05696302	CS99-03-ATR 208V 22A	208	22	1338
05696402	CS99-02-LVTR 480V 15A	480	15	1185
05696502	CS99-02-LVTR 277V 30A	277	30	1143
05696602	CS99-02-LVTR 240V 30A	240	30	1143
05696702	CS99-02-LVTR 208V 30A	208	30	1143
05696802	CS99-02-ATR 277V 18A	277	18	1263
05696902	CS99-02-ATR 240V 22A	240	22	1353
05697002	CS99-02-ATR 208V 22A	208	22	1382
05697102	CS99-01-LVTR 480V 15A	480	15	1112
05697202	CS99-01-LVTR 277V 30A	277	30	1073
05697302	CS99-01-LVTR 240V 30A	240	30	1073
05697402	CS99-01-LVTR 208V 30A	208	30	1073
05697502	CS99-01-ATR 277V 18A	277	18	1192
05697602	CS99-01-ATR 240V 22A	240	22	1283
05697702	CS99-01-ATR 208V 22A	208	22	1311

Control Section Notes:

01, 02 or 03 designates the cabinet size, either 1, 2, or 3 elements.

The 'ATR' control sections are supplied with a low voltage transformer/relay for 208, 240 or 277V single phase units only. These units are supplied with connection for low voltage thermostat.

The 'LVTR' control sections have a transformer and a relay. These control sections can be used with 208, 240, 277, or 480V single or three phase applications.

The 'PC' control sections are proportional control. The 'PC' control sections will accept either a 0-10 VDC or 4-20 MA signal from a building management system or a stand alone 0-10 VDC thermostat.

3900 Series Hydronic Electric Baseboard Heater



WARNING: This product can expose you to chemicals including nickel which is known to the State of California to cause cancer, and chromium, which is known to the State of California to cause birth defects and/or reproductive harm. For more information go to www.P65Warnings.ca.gov.



- Permanent mount self contained unit
- Heating elements are immersed in a heat transferring liquid enclosed by a Copper tube casing with Aluminum fins
- Powder coated 12 gauge heavy duty extruded Aluminum housing with junction boxes located on each end of the unit
- Automatic linear limit
- Wire guard extends along the entire outlet area of the baseboard
- Commercial Brown unit has in-built wireway
- Special colors available, consult factory
- Suitable for high altitude applications
- 1 Year element warranty
- Made in U.S.A.

Standard Models

STANDARD WHITE		COMMERCIAL BROWN		WATTS	BTUs	VOLTS	AMPS	HEATER LENGTH (IN.)	WT. (LBS)	WHITE LIST	BROWN LIST
MFG CATALOG NUMBER	MFG MODEL NUMBER	MFG CATALOG NUMBER	MFG MODEL NUMBER								
01114102	E3904-28	01116402	E3904-28C	400	1360	120	3.3	28	16	562	600
01114202	F3904-28	01116502	F3904-28C	400	1360	208	1.92	28	16	562	600
01114302	H3904-28	01116602	H3904-28C	400/300	1360/1024	240/208	1.6/1.4	28	16	562	600
01114402	G3904-28	01116702	G3904-28C	400/300	1360/1024	277/240	1.4/1.25	28	16	562	600
01114502	E3906-36	01116802	E3906-36C	600	2048	120	5	36	22	645	685
01114602	F3906-36	01116902	F3906-36C	600	2048	208	2.9	36	22	645	685
01114702	H3906-36	01117002	H3906-36C	600/450	2048/1536	240/208	2.5/2.2	36	22	645	685
01114802	G3906-36	01117102	G3906-36C	600/450	2048/1536	277/240	2.2/1.9	36	22	645	685
01114902	E3910-48	01117202	E3910-48C	1000	3413	120	8.3	48	27	753	796
01115002	F3910-48	01117302	F3910-48C	1000	3413	208	4.8	48	27	753	796
01115102	H3910-48	01117402	H3910-48C	1000/750	3413/2560	240/208	4.2/3.6	48	27	753	796
01115202	G3910-48	01117502	G3910-48C	1000/750	3413/2560	277/240	3.6/3.1	48	27	753	796
01115302	E3912-60	01117602	E3912-60C	1250	4265	120	10.4	60	33	853	929
01115402	F3912-60	01117702	F3912-60C	1250	4265	208	6	60	33	853	929
01115502	H3912-60	01117802	H3912-60C	1250/938	4265/3201	240/208	5.2/4.5	60	33	853	929
01115602	G3912-60	01117902	G3912-60C	1250/938	4265/3201	277/240	4.5/3.9	60	33	853	929
01115702	E3915-72	01118002	E3915-72C	1500	5100	120	12.5	72	41	958	1027
01115802	F3915-72	01118102	F3915-72C	1500	5100	208	7.2	72	41	958	1027
01115902	H3915-72	01118202	H3915-72C	1500/1125	5100/3825	240/208	6.3/5.4	72	41	958	1027
01116002	G3915-72	01118302	G3915-72C	1500/1125	5100/3825	277/240	5.4/4.7	72	41	958	1027
01116102	F3920-96	01118402	F3920-96C	2000	6826	208	9.6	96	58	1139	1225
01116202	H3920-96	01118502	H3920-96C	2000/1500	6826/5100	240/208	8.3/7.2	96	58	1139	1225
01116302	G3920-96	01118602	G3920-96C	2000/1500	6826/5100	277/240	7.2/6.3	96	58	1139	1225

Product Specifications & Dimensions

The entire heater casing shall be constructed of 6063 extruded Aluminum. Minimum thickness of .100" (12 gauge) Aluminum shall be acceptable. Outlet grill shall cover entire length of air discharge opening and be constructed of steel. All casing and grill construction shall be painted with high quality durable powder coated paint.

The heating element shall be high quality Nichrome wire encased in Magnesium Oxide and sealed in copper tube. The heating element shall be sealed in .312" diameter Copper tube and be immersed in heat transfer liquid. Aluminum fins shall be mechanically bonded to the entire heated length of the element for even heat transfer.

Linear automatic thermal limit shall extend the entire heater length of element and protect heater in case of an over-temperature condition.

Optional field installed controls shall be mounted in junction box enclosures at either end of heater. Optional integral thermostat shall be located in junction box with adjustment knob or for tamper-proof operation. Optional disconnect switch shall be mounted in junction box. Optional 120 Volt or air conditioning receptacle shall be mounted in junction box.

Optional installation accessories shall include inside and outside corner sections for complete wall perimeter fit. Profile of corners and grill shall have appearance of heat sections for continuous architectural design. Corner accessories and heater sections shall be secured by alignment pins for easy alignment of multiple heater applications.

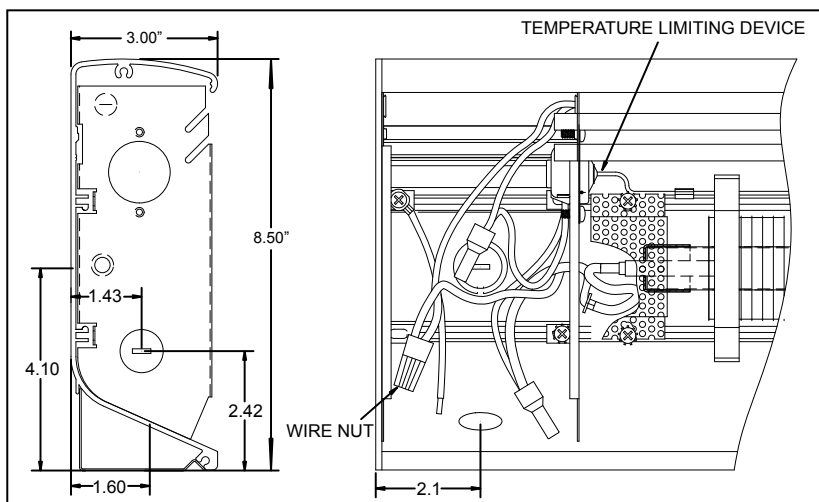

3700 Series Architectural Style Electric Baseboard Heater



- Available in white or brown with stainless steel heating element and aluminum fins
- Powder coated 12 gauge heavy duty extruded Aluminum housing construction with junction boxes located on each end of the unit
- An automatic thermal linear limit is used along the entire heated length of the unit
- Wire guard extends along the entire outlet area of the baseboard
- Special colors available, consult factory
- Made in U.S.A.



Standard Models

STANDARD WHITE		COMMERCIAL BROWN		WATTS	BTUs	VOLTS	AMPS	HEATER LENGTH (IN.)	WT. (LBS)	WHITE LIST	BROWN LIST
MFG CATALOG NUMBER	MFG MODEL NUMBER	MFG CATALOG NUMBER	MFG MODEL NUMBER								
01160002	E3703-024	01164302	E3703-024B	375	1275	120	3.1	24	14	486	506
01160102	F3703-024	01164402	F3703-024B	375	1275	208	1.8	24	14	486	506
01160202	H3703-024	01164502	H3703-024B	375 / 281	1275 / 955	240 / 208	1.6 / 1.4	24	14	486	506
01160302	G3703-024	01164602	G3703-024B	375 / 281	1275 / 955	277 / 240	1.6 / 1.2	24	14	486	506
01160402	E3705-028	01164702	E3705-028B	500	1706	120	4.2	28	16	537	558
01160502	F3705-028	01164802	F3705-028B	500	1706	208	2.4	28	16	537	558
01160602	H3705-028	01164902	H3705-028B	500 / 375	1706 / 1275	240 / 208	2.1 / 1.8	28	16	537	558
01160702	G3705-028	01165002	G3705-028B	500 / 375	1706 / 1275	277 / 240	1.8 / 1.6	28	16	537	558
01160802	E3706-036	01165102	E3706-036B	600	2040	120	5	36	22	622	643
01160902	F3706-036	01165202	F3706-036B	600	2040	208	2.9	36	22	622	643
01161002	H3706-036	01165302	H3706-036B	600 / 450	2040 / 1530	240 / 208	2.5 / 2.2	36	22	622	643
01161102	G3706-036	01165402	G3706-036B	600 / 450	2040 / 1530	277 / 240	2.2 / 1.9	36	22	622	643
01161202	E3707-040	01165502	E3707-040B	750	2550	120	6.3	40	27	633	654
01161302	F3707-040	01165602	F3707-040B	750	2550	208	3.6	40	27	633	654
01161402	H3707-040	01165702	H3707-040B	750 / 563	2550 / 1914	240 / 208	3.1 / 2.7	40	27	633	654
01161502	G3707-040	01165802	G3707-040B	750 / 563	2550 / 1914	277 / 240	2.7 / 2.6	40	27	633	654
01161602	E3710-048	01165902	E3710-048B	1000	3413	120	8.3	48	31	654	676
01161702	F3710-048	01166002	F3710-048B	1000	3413	208	4.8	48	31	654	676
01161802	H3710-048	01166102	H3710-048B	1000 / 750	3413 / 2550	240 / 208	4.2 / 3.6	48	31	654	676
01161902	G3710-048	01166202	G3710-048B	1000 / 750	3413 / 2550	277 / 240	3.6 / 3.1	48	31	654	676
01162002	G3707-048	01166302	G3707-048B	750	2550	277	3.4	48	31	654	676
01162102	E3712-060	01166402	E3712-060B	1250	4250	120	10.4	60	33	853	875
01162202	F3712-060	01166502	F3712-060B	1250	4250	208	6	60	33	853	875
01162302	H3712-060	01166602	H3712-060B	1250 / 938	4250 / 3189	240 / 208	5.2 / 4.5	60	33	853	875
01162402	G3712-060	01166702	G3712-060B	1250 / 938	4250 / 3189	277 / 240	4.5 / 3.9	60	33	853	875
01162502	G3709-060	01166802	G3709-060B	938	3189	277	3.4	60	33	853	875
01162602	E3715-072	01166902	E3715-072B	1500	5100	120	12.5	72	41	956	980
01162702	F3715-072	01167002	F3715-072B	1500	5100	208	7.2	72	41	956	980
01162802	H3715-072	01167102	H3715-072B	1500 / 1125	5100 / 3825	240 / 208	6.3 / 4.7	72	41	956	980
01162902	G3715-072	01167202	G3715-072B	1500 / 1125	5100 / 3825	277 / 240	5.4 / 4.7	72	41	956	980
01163002	G3711-072	01167302	G3711-072B	1125	3825	277	4.1	72	41	956	980
01163102	F3717-084	01167402	F3717-084B	1750	5950	208	8.4	84	49	1073	1095
01163202	H3717-084	01167502	H3717-084B	1750 / 1313	5950 / 4464	240 / 208	7.3 / 6.3	84	49	1073	1095
01163302	G3717-084	01167602	G3717-084B	1750 / 1313	5950 / 4464	277 / 240	6.3 / 5.5	84	49	1073	1095
01163402	G3713-084	01167702	G3713-084B	1313	4464	277	4.7	84	49	1073	1095
01163502	F3720-096	01167802	F3720-096B	2000	6826	208	9.6	96	58	1132	1168
01163602	H3720-096	01167902	H3720-096B	2000 / 1500	6826 / 5100	240 / 208	8.3 / 7.2	96	58	1132	1168
01163702	G3720-096	01168002	G3720-096B	2000 / 1500	6826 / 5100	277 / 240	7.2 / 6.3	96	58	1132	1168
01163802	G3715-096	01168102	G3715-096B	1500	5100	277	5.4	96	58	1132	1168
01163902	F3725-120	01168202	F3725-120B	2500	8532	208	12	120	67	1273	1292
01164002	H3725-120	01168302	H3725-120B	2500 / 1875	8532 / 6375	240 / 208	10.4 / 9.0	120	67	1273	1292
01164102	G3725-120	01168402	G3725-120B	2500 / 1875	8532 / 6375	277 / 240	9.0 / 7.8	120	67	1273	1292
01164202	G3718-120	01168502	G3718-120B	1875	6375	277	6.8	120	67	1273	1292

Note: Refer to 3900 Series for product dimension specification
 Note: See page 52 for custom color availability - add 10% to net heater cost

Product Specifications

- The entire heater casing shall be constructed of 6063 extruded Aluminum. Minimum thickness of .100" (12 gauge) Aluminum shall be acceptable. Outlet grill shall cover entire length of air discharge opening and be constructed of steel. All casing and grill construction shall be painted with high quality durable powder coated paint.
- The heating element shall be high quality Nichrome wire encased in Magnesium Oxide and sealed in a stainless steel tube.
- Linear automatic thermal limit shall extend the entire heater length of element and protect heater in case of an over-temperature condition.
- Optional field installed controls shall be mounted in junction box enclosures at either end of heater. Optional integral thermostat shall be located in junction box with adjustment knob or for tamper-proof operation. Optional field installed disconnect switch shall be mounted in junction box. Optional 120 Volt or air conditioning receptacle shall be mounted in junction box.
- Optional field installed accessories shall include inside and outside corner sections for complete wall perimeter fit. Profile of corners and grill shall have appearance of heat sections for continuous architectural design. Corner accessories and heater sections shall be secured by alignment pins for easy alignment of multiple heater applications.

Field Installed Accessories



3900T1C



3900T2C



3900ACC



3900RECC



3900DSC

DESCRIPTION	Standard White		Commercial Brown		LIST
	MFG CATALOG NUMBER	MFG MODEL NUMBER	MFG CATALOG NUMBER	MFG MODEL NUMBER	
Single Pole, In-Built T-Stat, 22A @ 120-240V; 18A @ 277V; 0°-110° F	01118702	3900T1	01119502	3900T1C	102
Double Pole, In-Built T-Stat, 22A @ 120-240V; 18A @ 277V; 0°-110° F	01118802	3900T2	01119602	3900T2C	131
Air Conditioning Receptacle Section, 20 Amp @ 125-277V	01118902	3900AC	01119902	3900ACC	120
120V. Receptacle Section, 15 Amp	01119002	3900REC	01120002	3900RECC	111
Disconnect Switch, 20 Amp @ 125-277VAC; DPST	01119402	3900DS	01120402	3900DSC	164



INSIDE CORNER



OUTSIDE CORNER

Baseboard Sections

STANDARD WHITE		COMMERCIAL BROWN		DESCRIPTION		LIST
MFG CATALOG NUMBER	MFG MODEL NUMBER	MFG CATALOG NUMBER	MFG MODEL NUMBER	SECTION	SIZE	
01121502	39BS28	0112215	39BS28C	Blank Section	28"	352
01121602	39BS36	0112222	39BS36C		36"	420
01121702	39BS48	0112239	39BS48C		48"	519
01121802	39BS60	0112246	39BS60C		60"	623
01121902	39BS72	0112253	39BS72C		72"	718
01122002	39BS96	0112260	39BS96C		96"	922
01150902	39BS120	0115100	39BS120C		120"	1230
01119102	3900-ICS	0112017	3900-ICSC	Inside Corner	-	203
01119202	3900-OCS	0112024	3900-OCSC	Outside Corner	-	206
01119302	3900-CS	01120302	3900-CSC	Control Section	4" Blank	258

Outside and inside corner sections are 6" on longest side.

Wireway Covers (White Units Only)

MFG CATALOG NUMBER	MFG MODEL NUMBER	LENGTH	WT. (LBS)	LIST
01122802	3900WW28	28"	2	80
01122902	3900WW36	36"	2.5	89
01123002	3900WW48	48"	3.5	104
01123102	3900WW60	60"	4.5	117
01123202	3900WW72	72"	5.5	125
01123302	3900WW96	96"	7.5	162
01151102	3900WW120	120"	7.5	218

Dimensions

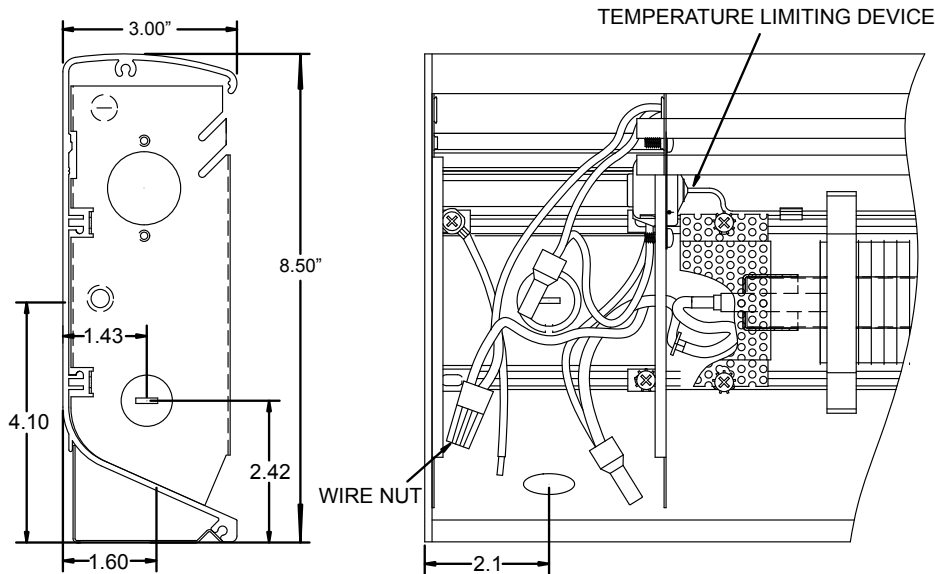

2900S Series Electric Baseboard - Stainless Steel Element Convection Heater

Features



- Available in white or ivory with stainless steel heating element and Aluminum fins
- Painted 22-gauge steel front with 20 gauge junction boxes located on each end of the heater - junction boxes contain quick connect cable clamps and 6" ground lead wires
- Over-temperature thermal limit extends entire length of heated area
- A full length wireway provided along the back of the heater - enclosed conduit available
- Heater can be mounted to the wall by using the key hole knockouts every 4" at the back of the heater
- Optional in-built thermostats field installed in the junction box
- For high altitude applications, delete the SW in the model number and add HAW
- Height: 6" Depth: 2 1/2"
- Made in U.S.A.



WARNING: This product can expose you to chemicals including nickel which is known to the State of California to cause cancer, and chromium, which is known to the State of California to cause birth defects and/or reproductive harm. For more information go to www.P65Warnings.ca.gov.

2900S Series Electric Baseboard - Stainless Steel Element Convection Heater

Standard Models

IVORY		WHITE		WATTS	BTUs	VOLTS	AMPS	HEATER LENGTH (IN)	WT. (LBS)	LIST
MFG CATALOG NUMBER	MFG MODEL NUMBER	MFG CATALOG NUMBER	MFG MODEL NUMBER							
01043002	E2903-024S	01049902	E2903-024SW	375	1275	120	3.1	24	5	96
01043102	F2903-024S	01050002	F2903-024SW	375	1275	208	1.8	24	5	96
01043202	H2903-024S	01050102	H2903-024SW	375 / 281	1275 / 955	240 / 208	1.6/1.4	24	5	96
01043302	G2903-024S	01050202	G2903-024SW	375 / 281	1275 / 955	277 / 240	1.6/1.2	24	5	96
01043402	E2905-028S	01050302	E2905-028SW	500	1706	120	4.2	28	6	98
01043502	F2905-028S	01050402	F2905-028SW	500	1706	208	2.4	28	6	98
01043602	H2905-028S	01050502	H2905-028SW	500 / 375	1706 / 1275	240 / 208	2.1/1.8	28	6	98
01043702	G2905-028S	01050602	G2905-028SW	500 / 375	1706 / 1275	277 / 240	1.8/1.6	28	6	98
01043802	E2906-036S	01050702	E2906-036SW	600	2040	120	5	36	7	115
01043902	F2906-036S	01050802	F2906-036SW	600	2040	208	2.9	36	7	115
01044002	H2906-036S	01050902	H2906-036SW	600 / 450	2040 / 1530	240 / 208	2.5/2.2	36	7	115
01044102	G2906-036S	01051002	G2906-036SW	600 / 450	2040 / 1530	277 / 240	2.2/1.9	36	7	115
01044202	E2907-040S	01051102	E2907-040SW	750	2550	120	6.3	40	8	118
01044302	F2907-040S	01051202	F2907-040SW	750	2550	208	3.6	40	8	118
01044402	H2907-040S	01051302	H2907-040SW	750 / 563	2550 / 1914	240 / 208	3.1/2.7	40	8	118
01044502	G2907-040S	01051402	G2907-040SW	750 / 563	2550 / 1914	277 / 240	2.7/2.6	40	8	118
01044602	E2910-048S	01051502	E2910-048SW	1000	3413	120	8.3	48	10	140
01044702	F2910-048S	01051602	F2910-048SW	1000	3413	208	4.8	48	10	140
01044802	H2910-048S	01051702	H2910-048SW	1000 / 750	3413 / 2550	240 / 208	4.2/3.6	48	10	140
01044902	G2910-048S	01051802	G2910-048SW	1000 / 750	3413 / 2550	277 / 240	3.6/3.1	48	10	140
01045002	G2907-048S	01051902	G2907-048SW	750	2550	277	3.4	48	10	140
01045102	E2912-060S	01052002	E2912-060SW	1250	4250	120	10.4	60	12	173
01030002	F2912-060S	01052102	F2912-060SW	1250	4250	208	6	60	12	173
01030102	H2912-060S	01052202	H2912-060SW	1250 / 938	4250 / 3189	240 / 208	5.2/4.5	60	12	173
01030202	G2912-060S	01052302	G2912-060SW	1250 / 938	4250 / 3189	277 / 240	4.5/3.9	60	12	173
01030302	G2909-060S	01052402	G2909-060SW	938	3189	277	3.4	60	12	173
01030402	E2915-072S	01052502	E2915-072SW	1500	5100	120	12.5	72	14	197
01030502	F2915-072S	01052602	F2915-072SW	1500	5100	208	7.2	72	14	197
01030602	H2915-072S	01052702	H2915-072SW	1500 / 1125	5100 / 3825	240 / 208	6.3/4.7	72	14	197
01030702	G2915-072S	01052802	G2915-072SW	1500 / 1125	5100 / 3825	277 / 240	5.4/4.7	72	14	197
01030802	G2911-072S	01052902	G2911-072SW	1125	3825	277	4.1	72	14	197
01030902	F2917-084S	01053002	F2917-084SW	1750	5950	208	8.4	84	16	218
01031002	H2917-084S	01053102	H2917-084SW	1750 / 1313	5950 / 4464	240 / 208	7.3/6.3	84	16	218
01031102	G2917-084S	01053202	G2917-084SW	1750 / 1313	5950 / 4464	277 / 240	6.3/5.5	84	16	218
01031202	G2913-084S	01053302	G2913-084SW	1313	4464	277	4.7	84	16	218
01031302	F2920-096S	01053402	F2920-096SW	2000	6826	208	9.6	96	18	240
01031402	H2920-096S	01053502	H2920-096SW	2000 / 1500	6826 / 5100	240 / 208	8.3/7.2	96	18	240
01031502	G2920-096S	01053602	G2920-096SW	2000 / 1500	6826 / 5100	277 / 240	7.2/6.3	96	18	240
01031602	G2915-096S	01053702	G2915-096SW	1500	5100	277	5.4	96	18	240
01032102	F2925-120S	01054202	F2925-120SW	2500	8532	208	12	120	22	263
01032202	H2925-120S	01054302	H2925-120SW	2500 / 1875	8532 / 6375	240 / 208	10.4/9.0	120	22	263
01032302	G2925-120S	01054402	G2925-120SW	2500 / 1875	8532 / 6375	277 / 240	9.0/7.8	120	22	263
01032402	G2918-120S	01054502	G2918-120SW	1875	6375	277	6.8	120	22	263

2900A Series - International Models

WHITE		WATTS	BTUs	VOLTS	HEATER LENGTH (IN)	WT. (LBS)	LIST
MFG CATALOG NUMBER	MFG MODEL NUMBER						
01157602	M2903-24AWi	375	1275	220	24"	10	134
01157702	H2903-24AWi	375	1275	240	24"	11	127
01157802	M2905-28AWi	500	1706	220	28"	11	133
01159702	H2905-28AWi	500	1706	240	28"	12	145
01158002	M2906-36AWi	600	2040	220	36"	11.5	145
01158102	H2906-36AWi	600	2040	240	36"	12.5	152
01158202	M2907-40AWi	750	2550	220	40"	13	152
01158302	H2907-40AWi	750	2550	240	40"	14	181
01158402	M2910-48AWi	1000	3413	220	48"	14	181
01158502	H2910-48AWi	1000	3413	240	48"	15	228
01158602	M2912-60AWi	1250	4250	220	60"	16	228
01158702	H2912-60AWi	1250	4250	240	60"	17	257
01158802	M2915-72AWi	1500	5100	220	72"	19	257
01158902	H2915-72AWi	1500	5100	240	72"	20	311
01159002	M2917-84AWi	1750	5950	220	84"	22	133
01180002	H2917-84AWi	1750	5950	240	84"	23	311
01180302	M2925-120AWi	2500	8532	220	120"	31	362
01180402	H2920-120AWi	2500	8532	240	120"	32	344

Note: Wireway length is the same as baseboard length.

2900C Series Electric Baseboard - Heavy Duty Commercial Convection Heater



WARNING: This product can expose you to chemicals including nickel which is known to the State of California to cause cancer, and chromium, which is known to the State of California to cause birth defects and/or reproductive harm. For more information go to www.P65Warnings.ca.gov.

- Bankers bronze with stainless steel heating element and Aluminum fins
- Powder coated 22 gauge steel front with 20 gauge junction boxes located on each end of the heater - junction boxes contain quick connect cable clamps and 6" ground lead wires
- Standard inlet and outlet wire guards
- Over-temperature thermal limit extends entire heated length of unit
- A full length wire way provided along the back of the heater
- Heater can be mounted to the wall by using the key hole knockouts every 4" at the back of the heater
- Optional in-built thermostats field installed in the junction box
- Height: 6" Depth: 2 1/2"
- Made in U.S.A.

Standard Models

MFG CATALOG NUMBER	MFG MODEL NUMBER	WATTS	BTUs	VOLTS	AMPS	HEATER LENGTH (IN)	WT. (LBS)	LIST
01038302	E2903-024C	375	1275	120	3.1	24	5	222
01038402	F2903-024C	375	1275	208	1.8	24	5	222
01038502	H2903-024C	375 / 281	1275 / 955	240 / 208	1.6 / 1.4	24	5	222
01038602	G2903-024C	375 / 281	1275 / 955	277 / 240	1.6 / 1.2	24	5	222
01038702	E2905-028C	500	1706	120	4.2	28	6	276
01038802	F2905-028C	500	1706	208	2.4	28	6	276
01038902	H2905-028C	500 / 375	1706 / 1275	240 / 208	2.1 / 1.8	28	6	276
01039002	G2905-028C	500 / 375	1706 / 1275	277 / 240	1.8 / 1.6	28	6	276
01039102	E2906-036C	600	2040	120	5.0	36	7	315
01039202	F2906-036C	600	2040	208	2.9	36	7	315
01039302	H2906-036C	600 / 450	2040 / 1530	240 / 208	2.5 / 2.2	36	7	315
01039402	G2906-036C	600 / 450	2040 / 1530	277 / 240	2.2 / 1.9	36	7	315
01039502	E2907-040C	750	2550	120	6.3	40	8	331
01039602	F2907-040C	750	2550	208	3.6	40	8	331
01039702	H2907-040C	750 / 563	2550 / 1914	240 / 208	3.1 / 2.7	40	8	331
01039802	G2907-040C	750 / 563	2550 / 1914	277 / 240	2.7 / 2.6	40	8	331
01039902	E2910-048C	1000	3413	120	8.3	48	10	382
01040002	F2910-048C	1000	3413	208	4.8	48	10	382
01040102	H2910-048C	1000 / 750	3413 / 2550	240 / 208	4.2 / 3.6	48	10	382
01040202	G2910-048C	1000 / 750	3413 / 2550	277 / 240	3.6 / 3.1	48	10	382
01040302	G2907-048C	750	2550	277	3.4	48	10	382
01040402	E2912-060C	1250	4250	120	10.4	60	12	454
01040502	F2912-060C	1250	4250	208	6.0	60	12	454
01040602	H2912-060C	1250 / 938	4250 / 3189	240 / 208	5.2 / 4.5	60	12	454
01040702	G2912-060C	1250 / 938	4250 / 3189	277 / 240	4.5 / 3.9	60	12	454
01040802	G2909-060C	938	3189	277	3.4	60	12	454
01040902	E2915-072C	1500	5100	120	12.5	72	14	521
01041002	F2915-072C	1500	5100	208	7.2	72	14	521
01041102	H2915-072C	1500 / 1125	5100 / 3825	240 / 208	6.3 / 4.7	72	14	521
01041202	G2915-072C	1500 / 1125	5100 / 3825	277 / 240	5.4 / 4.7	72	14	521
01041302	G2911-072C	1125	3825	277	4.1	72	14	521
01041402	F2917-084C	1750	5950	208	8.4	84	16	580
01041502	H2917-084C	1750 / 1313	5950 / 4464	240 / 208	7.3 / 6.3	84	16	580
01041602	G2917-084C	1750 / 1313	5950 / 4464	277 / 240	6.3 / 5.5	84	16	580
01041702	G2913-084C	1313	4464	277	4.7	84	16	580
01041802	F2920-096C	2000	6826	208	9.6	96	18	640
01041902	H2920-096C	2000 / 1500	6826 / 5100	240 / 208	8.3 / 7.2	96	18	640
01042002	G2920-096C	2000 / 1500	6826 / 5100	277 / 240	7.2 / 6.3	96	18	640
01042102	G2915-096C	1500	5100	277	5.4	96	18	640
01042602	F2925-120C	2500	8532	208	12.0	120	22	672
01042702	H2925-120C	2500 / 1875	8532 / 6375	240 / 208	10.4 / 9.0	120	22	672
01042802	G2925-120C	2500 / 1875	8532 / 6375	277 / 240	9.0 / 7.8	120	22	672
01042902	G2918-120C	1875	6375	277	6.8	120	22	672

International Models

MFG CATALOG NUMBER	MFG MODEL NUMBER	WATTS	BTUs	VOLTS	AMPS	HEATER LENGTH (IN)	WT. (LBS)	LIST
01180502	M2903-024CI	375	1275	220	1.7	24	5	215
01180602	H2903-024CI			240	240	24	5	215
01180702	M2905-028CI	500	1706	220	2.3	28	6	268
01180802	H2905-028CI			240	2.1	28	6	268
01180902	M2906-036CI	600	2040	220	2.7	36	7	304
01181002	H2906-036C			240	2.5	36	7	304
01181102	M2907-040CI	750	2550	220	3.4	40	8	319
01181202	H2907-040C			240	3.1	40	8	319
01181302	M2910-048CI	1000	3413	220	4.6	48	10	372
01181402	H2910-048CI			240	4.2	48	10	372
01181502	M2912-060CI	1250	4250	220	5.7	60	12	440
01181602	H2912-060C			240	5.2	60	12	440
01181702	M2915-072CI	1500	5100	220	6.8	72	14	532
01181802	H2915-072CI			240	6.3	72	14	532
01181902	M2917-084CI	1750	5950	220	8.0	84	16	561
01182002	H2917-084CI			240	7.3	84	16	561
01182102	M2920-096CI	2000	6826	220	9.1	96	18	621
01182202	H2920-096CI			240	8.3	96	18	621
01182302	M2925-120CI	2500	8532	220	11.4	120	22	651
01182402	H2925-120CI			240	10.4	120	22	651

Electric Baseboard - Accessories

In-Built Thermostat Kits

MFG CATALOG NUMBER	MFG MODEL NUMBER	DESCRIPTION	WT. (LBS)	LIST
01054602C	TBS	SPST-In-Built 22A @ 120-240V 18A @ 277V (0°-110°F)	1/2	68
01054702C	TBD	DPST-In-Built 22A @ 120-240V 18A @ 277V (0°-110°F)	1/2	87

*Junction box covers supplied with baseboard heater will work in conjunction with in-built thermostat kits.

WARNING: This product can expose you to chemicals including nickel which is known to the State of California to cause cancer, and chromium, which is known to the State of California to cause birth defects and/or reproductive harm. For more information go to www.P65Warnings.ca.gov.

Field Installed Accessories

DESCRIPTION	IVORY		WHITE		BANKERS BRONZE		WT. (LBS)	LIST
	MFG CATALOG NUMBER	MFG MODEL NUMBER	MFG CATALOG NUMBER	MFG MODEL NUMBER	MFG CATALOG NUMBER	MFG MODEL NUMBER		
Disconnect Switch, 20 Amp, 120-277V	01061002	DS	01061102	DSW	01061202	DSB	1	130
Corner Sections	01054902	CS	01055002	CSW	01055102	CSB		58
1" Joiner Kits	01055202	JK	01055302	JKW	01055402	JKB	1/4	41
6" Blank Relay Section (Relay Not Included)**	01055502	LVRS	01055602	LVRSW	01055702	LVRSB	1 1/2	157
Receptacle Section (Baseboard Mounted) 15 Amp 120 VAC	01055802	BDR115	01055902	BDR115W	01056002	BDR115B	2	41
Receptacle Section (Mounted in 6" Blank) 15 Amp 120 VAC	01056102	DR115	01056202	DR115W	01056302	DR115B		183
Transfer Switch (Mounted in 6" Blank) 16 Amp 120 VAC	01056402	SR120	01056502	SR120W	01056602	SR120B		231
Transfer Switch (Mounted in 6" Blank) 16 Amp 240 VAC	01056702	SR220	01056802	SR220W	01056902	SR220B		281

**Not for use with 24A06G-1 relay

WARNING: This product can expose you to chemicals including nickel which is known to the State of California to cause cancer, and chromium, which is known to the State of California to cause birth defects and/or reproductive harm. For more information go to www.P65Warnings.ca.gov.

Optional Wireway Covers

Blank Sections

MFG CATALOG NUMBER	MFG MODEL NUMBER	LENGTH (in.)	COVER LENGTH (in.)	WT. (LBS)	LIST	LENGTH	IVORY		WHITE		BANKERS BRONZE		WT. (LBS)	IVORY WHITE LIST	BRONZE LIST
							MFG CATALOG NUMBER	MFG MODEL NUMBER	MFG CATALOG NUMBER	MFG MODEL NUMBER	MFG CATALOG NUMBER	MFG MODEL NUMBER			
01057002	WWA01	24"	20	1	55	24"	01058002	BBS024A	01059002	BBS024AW	01060002	BBS024C	5	87	180
01057102	WWA02	28"	24	1.5	60	28"	01058102	BBS028A	01059102	BBS028AW	01060102	BBS028C	5 1/2	95	195
01057202	WWA03	36"	32	2	68	36"	01058202	BBS036A	01059202	BBS036AW	01060202	BBS036C	6	117	225
01057302	WWA04	40"	36	2.5	77	40"	01058302	BBS040A	01059302	BBS040AW	01060302	BBS040C	7	125	237
01057402	WWA05	48"	44	3	79	48"	01058402	BBS048A	01059402	BBS048AW	01060402	BBS048C	8	140	242
01057502	WWA06	60"	56	4	84	60"	01058502	BBS060A	01059502	BBS060AW	01060502	BBS060C	10	166	335
01057602	WWA07	72"	68	5	96	72"	01058602	BBS072A	01059602	BBS072AW	01060602	BBS072C	12	199	370
01057702	WWA08	84"	80	6	110	84"	01058702	BBS084A	01059702	BBS084AW	01060702	BBS084C	15	208	419
01057802	WWA09	96"	92	7	126	96"	01058802	BBS096A	01059802	BBS096AW	01060802	BBS096C	17	243	470
01057902	WWA00	120"	116	8	152	120"	01058902	BBS120A	01059902	BBS120AW	01060902	BBS120C	20	299	590

WARNING: This product can expose you to chemicals including nickel which is known to the State of California to cause cancer, and chromium, which is known to the State of California to cause birth defects and/or reproductive harm. For more information go to www.P65Warnings.ca.gov.

Mul-T-Mount Electric Infrared Heaters

Quartz Lamp Mul-T-Mount Heaters

- Short wavelength radiant heat emitter for indoor & total exposed outdoor heating applications
- Gold anodized interior reflector offered in symmetrical or asymmetrical heat pattern options
- Clear quartz lamp operates at 96% radiant efficiency & generates 8 Lumens per Watt
- Designed for indoor and totally exposed outdoor heating application areas
- Element life expectancy of 5,000 hours

WARNING: This product can expose you to chemicals including nickel which is known to the State of California to cause cancer, and chromium, which is known to the State of California to cause birth defects and/or reproductive harm. For more information go to www.P65Warnings.ca.gov.



TH/THSS Series & TH/THSS-AG Series

- Housing finish: bankers bronze or stainless steel
- Designed for rugged industrial applications
- Chain, suspension, wall, or recessed mounting options
- Shipped with clear quartz lamp
- AG suffix models include "glare" reducing sleeves



THA Series

- Extruded aluminum housing
- Nickel gray finish
- Designed for commercial applications
- Chain or suspension mounting options
- Shipped with clear quartz lamps and amber gray "glare" reducing sleeves
- Provides 94% element glare reduction for all heating indoor and outdoor applications

Product Specifications

Series:

222, 342, 462 (Painted Version) 2-lamp -- TH Series
222, 342, 462 (Stainless Steel Version) 2-lamp -- THSS Series
223, 343, 463 (Stainless Steel Version) 3-lamp -- THSS Series

Housing:

20-gauge Galvanized Steel with baked on bankers' bronze powder coated finish. 20-gauge Stainless Steel for durability and corrosion-resistance. Both housings are ETL Listed for either indoor or totally exposed outdoor applications.

Reflectors and End Caps:

.040 Gold anodized Aluminum reflectors and end caps for superior reflectivity. Five choices of reflector patterns including 30 narrow (symmetric & asymmetric), 60 degree medium (symmetric & asymmetric), and 90 degrees wide (symmetric). THSS models have stainless steel endcaps.

Elements:

Clear quartz lamps. Coiled tungsten filament located within a sealed quartz envelope, halogen filled, with porcelain end caps and 6" wire pigtail leads. Elements are 12mm in diameter and deliver a 96% radiant efficiency with high moisture and thermal shock resistance. Instantaneous heat-up and cool-down performance. Available wattages from 1600 to 3650 Watts per element. Available voltages from 208 to 600 Volts.

Controls:

Mul-T-Mount heaters are not manufactured with any control device on the unit. All controls are accessories and should be specified as such. Please consult the technical sales department of factory for help in determining applicable controls. Please follow installation instructions that accompany each heater.

Accessories:

Recessed mounting frames (painted or stainless steel), adjustable mounting brackets (stainless steel only), vertical mounting brackets (stainless steel only), wire guards, thermostats, snow detectors, SCR controllers, and power contactor panels (ICP Series).

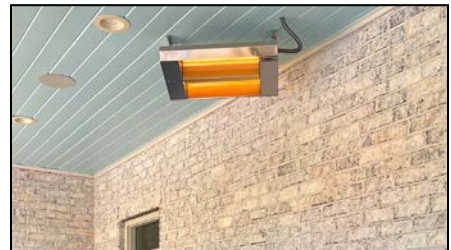

Quartz Lamp Glare Reduction Options



12mm Clear Quartz Lamp

- Approximately 96% radiant efficient
- 8 lumens per watt on a 3200 watt fixture, equals 25,600 lumens
- Can be mounted 10' and above indoors, 8' to 10' outdoors
- Emits a bright light, but extremely energy efficient site of installation



12mm Red Vycor Sleeve

- Slips over 12mm quartz lamp to reduce glare
- Filters approximately 90% of visible light
- Allows 90% of the energy to pass through to installed area
- Reduces 90% of the clear quartz lumens



8mm Clear Quartz Lamp with Amber Gray Sleeve

- When used together, reduces 94% of lumens of clear quartz lamp
- Allows 90% of energy to pass through sleeve to installed area
- Eliminates red glow found with using red vycor sleeve
- Shipped standard on all AG suffix & THA model series

Features:

In-built surface mounting brackets allows for fixture adjustment up to 45° horizontal tilt

In-built surface mounting brackets attached to the top wiring channel

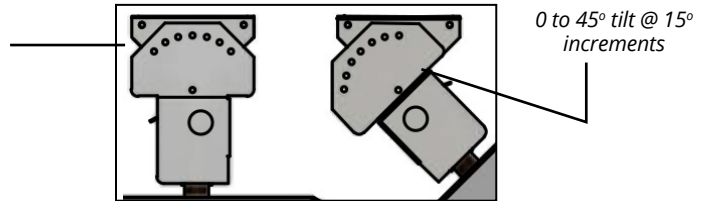

Product Dimensions

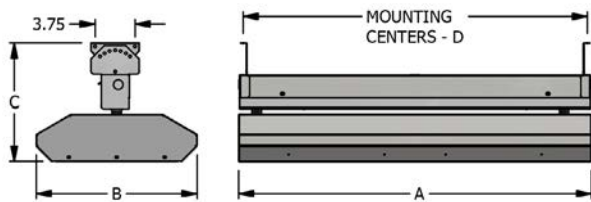

MUL-T-MOUNT SERIES	DIMENSIONS (IN.)			
	"A" LENGTH	"B" WIDTH	"C" HEIGHT	"D" MTG.CTR.
222	24"	15"	11"	23 1/2"
223	24"	21 1/2"	11"	23 1/2"
342	33"	15"	11"	32 1/2"
343	33"	21 1/2"	11"	32 1/2"
462	46"	15"	11"	45 1/2"
463	46"	21 1/2"	11"	45 1/2"

Mounting Clearances & Recommended Mounting Height

Mounting Clearances		Recommended Mounting Height	
2 & 3 Lamp Models	3" from ceiling	30° Symmetric & A30° Asymmetric Reflector - Indoor	14' - 30'
	24" from vertical surface	60° Symmetric & A60° Asymmetric Reflector - Indoor	12' - 18'
2 Lamp Models	72" from face of heater to combustible surface	90° Symmetric Reflector - Indoor	8' - 12'
3 Lamp Models	96" from face of heater to combustible surface	30° Symmetric & A30° Asymmetric Reflector - Outdoor	8' - 10'

Reflector Pattern Options

How to Choose the Correct Reflective Pattern:

1. Know your application usage type
2. Know if the heater will be used indoors or outdoors
3. Know if the heater will be recessed or surface mounted
4. Know if the heater can be tilted or requires asymmetrical reflective pattern to extend pattern from a vertical surface
5. If outdoors, know if heater is being used for spot heat or snow & ice prevention heat system

Two types of inner reflectors offered:

- Symmetrical Pattern
- Asymmetrical Pattern

Three types of degree patterns:

1. 30° Symmetrical or Asymmetric
2. 60° Symmetrical or Asymmetric
3. 90° Symmetrical

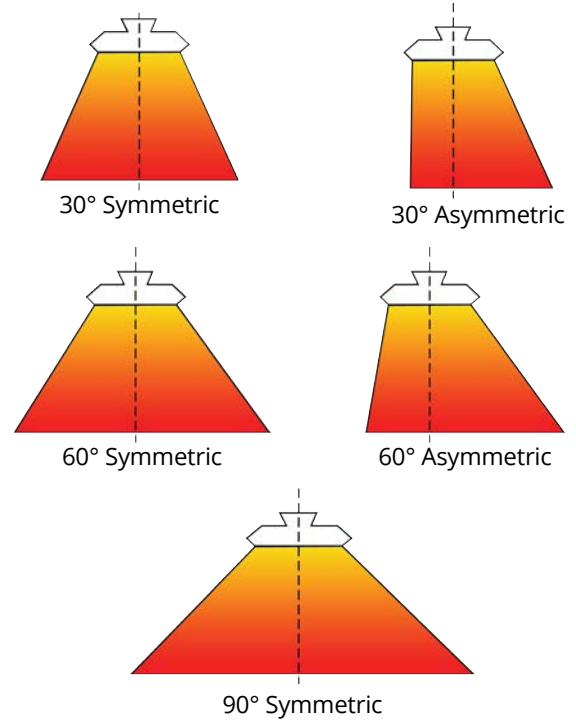

Benefits of Each Degree Pattern:

30° Patterns:

- Should be used outdoors or for indoor high-bay heating applications
- Primary pattern for outdoor snow & ice prevention heat systems

60° Patterns:

- Most common reflector selected
- Provides ideal heat patterns for indoor spot heating areas.
- Can be used for outdoor spot heating applications with low mounting heights requiring minimal temperature rises.

90° Patterns:

- Ideal for low ceiling heights
- Primary pattern for indoor total area heating applications requiring less than 15-Watts sq.ft.

Types of Electric Infrared Applications

- Indoor spot heating
- Outdoor spot heating
- Total area/building heating
- Outdoor snow & ice control heating systems

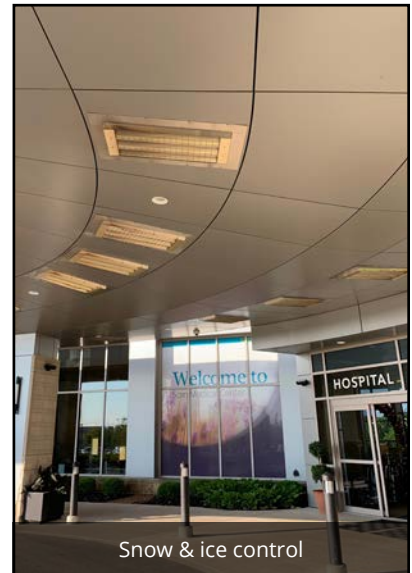

Sizing Chart

Reflective Pattern (°)	Heater Output (kW)	# of Qtz. Lamps	Mounting Heights (FT.)						Watts Delivered per Square Foot							
			8	10	12	14	16	18	20	Mounting Heights (FT.)						
			Heat Pattern Coverage at Floor Level						8	10	12	14	16	18	20	
			L x W	L x W	L x W	L x W	L x W	L x W	L x W	L x W	L x W	L x W	L x W	L x W	L x W	
30°	3.2	2 - Quartz Lamp Heaters	5.5 x 4	6.5 x 5.5	7.5 x 6.5	8.5 x 7.5	9.5 x 8.5	10.5 x 9.5	11.5 x 10.5	145.5	89.5	65.6	50.2	39.6	32.1	26.5
60°	3.2		10.5 x 9.5	13 x 12	15 x 14	17 x 16	N/R	N/R	N/R	32.1	20.5	15.2	11.8	-	-	-
90°	3.2		17 x 16	21 x 20	N/R	N/R	N/R	N/R	N/R	11.8	7.6	-	-	-	-	-
30°	5.0		6 x 4	7.5 x 5.5	8.5 x 6.5	9.5 x 7.5	10.5 x 8.5	11.5 x 9.5	12.5 x 10.5	208.3	121.2	90.5	70.2	56.0	45.8	38.1
60°	5.0		11.5 x 9.5	14 x 12	16 x 14	18 x 16	20.5 x 18.5	23 x 21	N/R	45.8	29.8	22.3	17.4	13.2	10.4	-
90°	5.0		18 x 16	22 x 20	26 x 24	N/R	N/R	N/R	N/R	17.4	11.4	8.0	-	-	-	-
30°	7.3		N/R	8.5 x 5.5	9.5 x 6.5	10.5 x 7.5	11.5 x 8.5	12.5 x 9.5	13.5 x 10.5	-	156.1	118.2	92.7	74.7	61.5	51.5
60°	7.3		12 x 10.5	15 x 12	17 x 14	19 x 16	21.5 x 18.5	24 x 21	N/R	57.9	40.6	30.7	24.0	18.4	14.5	-
90°	7.3		19 x 16	23 x 20	27 x 24	N/R	N/R	N/R	N/R	24.0	15.9	11.3	-	-	-	-
30°	4.8	3 - Quartz Lamp Heaters	5.5 x 5	6.5 x 6.5	7.5 x 7.5	8.5 x 8.5	9.5 x 9.5	10.5 x 10.5	11.5 x 11.5	174.5	113.6	85.3	66.4	53.2	43.5	36.3
60°	4.8		10.5 x 10.5	13 x 13	15 x 15	17 x 17	21 x 21	N/R	N/R	43.5	28.4	21.3	16.6	10.9	-	-
90°	4.8		17 x 17	21 x 21	N/R	N/R	N/R	N/R	N/R	16.6	10.9	-	-	-	-	-
30°	7.5		N/R	7.5 x 6.5	8.5 x 7.5	9.5 x 8.5	10.5 x 9.5	11.5 x 10.5	12.5 x 11.5	-	153.8	117.6	92.9	75.2	62.1	52.2
60°	7.5		11.5 x 10.5	14 x 13	16 x 15	18 x 17	20.5 x 19.5	23 x 22	N/R	62.1	41.2	31.3	24.5	18.8	14.8	-
90°	7.5		18 x 17	22 x 21	26 x 25	N/R	N/R	N/R	N/R	24.5	16.2	11.5	-	-	-	-
30°	10.95		N/R	8.5 x 6.5	9.5 x 7.5	10.5 x 8.5	11.5 x 9.5	12.5 x 10.5	13.5 x 11.5	-	198.2	153.7	122.7	100.2	83.4	70.5
60°	10.95		12 x 11	15 x 13	17 x 15	19 x 17	21.5 x 19.5	24 x 22	N/R	83.0	56.2	42.9	33.9	26.1	20.7	-
90°	10.95		19 x 17	23 x 21	27 x 25	N/R	N/R	N/R	N/R	33.9	22.7	16.2	-	-	-	-

NOTE: This chart provides the same heat pattern coverage for all Mul-T-Mount Heater Series regardless of housing materials, added sleeve, or element diameter.

Infrared Calculations & Sizing Details

Indoor Spot Heating

Average: 25-60 Watts per square foot

Calculation: Sq.ft. x desired temperature rise = TOTAL Watts required

Principles of Indoor Spot Heating:

- always cross beam patterns
- always try to heat from both sides of object
- avoid mounting below 8'
- avoid mounting unit directly over an individual's head

Total Area / Building Heating

Average: 8-20 watts per square foot

Calculation: Sq.ft. x .5 x desired temperature rise = TOTAL Watts required

Principles of Total Area/ Building Heating:

- always complete a "heat loss" calculation
- concentrate heat on perimeter areas
- avoid mounting below 8'
- avoid mounting unit directly over individual's head

Outdoor Spot Heating

Average: 2 watts per square foot per desired temperature rise

Calculation: Sq.ft. x 2 x desired temperature rise = TOTAL Watts required

Principles of Outdoor Spot Heating:

- use quartz lamps or quartz tubes
- always use the MTM, OCH, RPH heaters
- avoid 90° pattern heaters
- strive for blanket coverage of an area

Outdoor Snow & Ice Control Heating System

Average: 25-60 Watts per square foot

Calculation: Sq.ft. x required watts / sq.ft. = TOTAL Watts req.

Principles of Snow & Ice Control Heating:

- always use quartz lamps
- always use Mul-T-Mount heater models
- strive for blanket coverage of an area
- avoid 90° patterns
- never mount above 16'



TH & THSS Series Mul-T-Mount Electric Infrared Heaters

Product Description

- Available in 2 or 3-lamp Bankers Bronze or stainless steel finish
- Listed for suspended, totally exposed (outdoor, high-bay indoor) comfort heating and exterior snow & ice control applications
- Listed for recessed applications
- 20 gauge powder coated steel or stainless steel housings
- Gold anodized Aluminum reflectors & end caps
- 50% higher wattage densities for 3-element units
- 2-lamp wiring, single phase
- 3-lamp wiring, three or single phase
- Stainless steel models have non-corrosive housing, hardware and brackets. Durable in harsh atmospheres & outdoor environments.
- High temperature lead wires
- Clear 12mm diameter quartz lamp(s) included
- Elements provide a bright light, generating 8 Lumens per Watt
- Made in U.S.A.

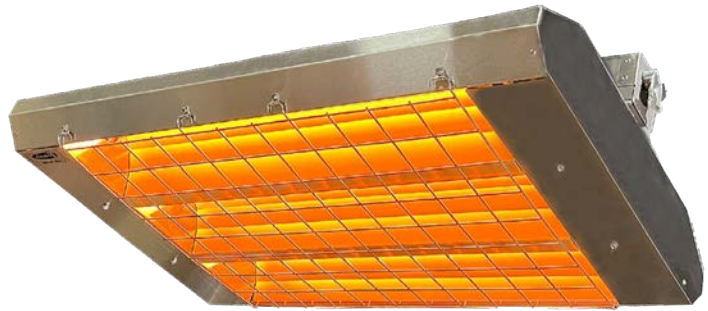

3-Lamp Stainless Steel Infrared Heater
(shown with CHWG Guard)

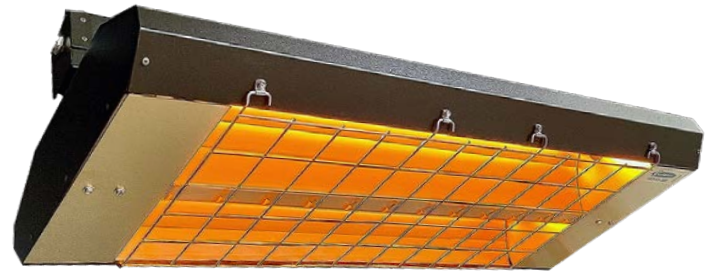

2-Lamp Bankers Bronze Infrared Heater

WARNING: This product can expose you to chemicals including nickel which is known to the State of California to cause cancer, and chromium, which is known to the State of California to cause birth defects and/or reproductive harm. For more information go to www.P65Warnings.ca.gov.



NOTE: 600-Volt models also available, contact factory for more information
Asymmetrical pattern units are also available for 30° & 60°

3-Lamp Mul-T-Mount Series - Bankers Bronze Or Stainless Steel Housing With (3) Clear 12 mm Quartz Lamps Included

BRONZE HOUSING		STAINLESS STEEL HOUSING		KW	BTUs	VOLTS	REFLECTOR PATTERN	12mm DIAMETER REPLACEMENT LAMP (see pg. 89)	WT. (LBS)	LIST	
MFG CATALOG NUMBER	MFG MODEL NUMBER	MFG CATALOG NUMBER	MFG MODEL NUMBER							Bankers Bronze	Stainless Steel
04874802	223-30-TH-208V	04436702	223-30-THSS-208V	4.8	16382	208	30° Symmetrical	63016209	25	1707	1921
04874902	223-30-TH-240V	04436802	223-30-THSS-240V	4.8	16382	240	30° Symmetrical	63016249	25	1707	1921
04875002	223-30-TH-277V	04436902	223-30-THSS-277V	4.8	16382	277	30° Symmetrical	63016279	25	1707	1921
04875102	223-30-TH-480V	04815802	223-30-THSS-480V	4.8	16382	480	30° Symmetrical	63016489	25	1707	1921
04875202	223-60-TH-208V	04432802	223-60-THSS-208V	4.8	16382	208	60° Symmetrical	63016209	25	1707	1921
04875302	223-60-TH-240V	04437302	223-60-THSS-240V	4.8	16382	240	60° Symmetrical	63016249	25	1707	1921
04875402	223-60-TH-277V	04437402	223-60-THSS-277V	4.8	16382	277	60° Symmetrical	63016279	25	1707	1921
04875502	223-60-TH-480V	04815902	223-60-THSS-480V	4.8	16382	480	60° Symmetrical	63016489	25	1707	1921
04875602	223-90-TH-208V	04437802	223-90-THSS-208V	4.8	16382	208	90° Symmetrical	63016209	25	1707	1921
04875702	223-90-TH-240V	04437902	223-90-THSS-240V	4.8	16382	240	90° Symmetrical	63016249	25	1707	1921
04875802	223-90-TH-277V	04438002	223-90-THSS-277V	4.8	16382	277	90° Symmetrical	63016279	25	1707	1921
04875902	223-90-TH-480V	04816002	223-90-THSS-480V	4.8	16382	480	90° Symmetrical	63016489	25	1707	1921
04876002	343-30-TH-208V	04812302	343-30-THSS-208V	7.5	25298	208	30° Symmetrical	63025209	33	2062	2448
04876102	343-30-TH-240V	04812402	343-30-THSS-240V	7.5	25298	240	30° Symmetrical	63025249	33	2062	2448
04876202	343-30-TH-480V	88114394	343-30-THSS-480V	7.5	25298	480	30° Symmetrical	63025489	33	2062	2448
04876302	343-60-TH-208V	04812602	343-60-THSS-208V	7.5	25298	208	60° Symmetrical	63025209	33	2062	2448
04876402	343-60-TH-240V	04812702	343-60-THSS-240V	7.5	25298	240	60° Symmetrical	63025249	33	2062	2448
04876502	343-60-TH-480V	88116394	343-60-THSS-480V	7.5	25298	480	60° Symmetrical	63025489	33	2062	2448
04876602	343-90-TH-208V	04812902	343-90-THSS-208V	7.5	25298	208	90° Symmetrical	63025209	33	2062	2448
04876702	343-90-TH-240V	04813002	343-90-THSS-240V	7.5	25298	240	90° Symmetrical	63025249	33	2062	2448
04876802	343-90-TH-480V	88118394	343-90-THSS-480V	7.5	25298	480	90° Symmetrical	63025489	33	2062	2448
04876902	463-30-TH-480V	88105394	463-30-THSS-480V	10.95	37372	480	30° Symmetrical	63036489	41	2477	2867
04877002	463-60-TH-480V	88107394	463-60-THSS-480V	10.95	37372	480	60° Symmetrical	63036489	41	2477	2867
04877102	463-90-TH-480V	88109394	463-90-THSS-480V	10.95	37372	480	90° Symmetrical	63036489	41	2477	2867

TH & THSS Series Mul-T-Mount Electric Infrared Heaters

2-Lamp Mul-T-Mount Series Bankers Bronze Or
Stainless Steel With (2) Clear 12mm Quartz Lamps Included

BRONZE HOUSING		STAINLESS STEEL HOUSING		KW	BTUs	VOLTS	REFLECTOR PATTERN	12mm DIAMETER REPLACEMENT LAMP (see pg. 89)	WT. (LBS)	LIST	
MFG CATALOG NUMBER	MFG MODEL NUMBER	MFG CATALOG NUMBER	MFG MODEL NUMBER							Bankers Bronze	Stainless Steel
04441602	222-30-TH-208V	04444002	222-30-THSS-208V	3.2	10,922	208	30° Symmetrical	63016209	20	1033	1248
04441702	222-30-TH-240V	04444102	222-30-THSS-240V	3.2	10,922	240	30° Symmetrical	63016249	20	1033	1248
04441802	222-30-TH-277V	04444202	222-30-THSS-277V	3.2	10,922	277	30° Symmetrical	63016279	20	1033	1248
04813802	222-30-TH-480V	04814302	222-30-THSS-480V	3.2	10,922	480	30° Symmetrical	63016489	20	1033	1248
04441902	222-A30-TH-208V	04444302	222-A30-THSS-208V	3.2	10,922	208	30° Asymmetrical	63016209	20	1033	1248
04442002	222-A30-TH-240V	04444402	222-A30-THSS-240V	3.2	10,922	240	30° Asymmetrical	63016249	20	1033	1248
04442102	222-A30-TH-277V	04444502	222-A30-THSS-277V	3.2	10,922	277	30° Asymmetrical	63016279	20	1033	1248
04814102	222-A30-TH-480V	04814602	222-A30-THSS-480V	3.2	10,922	480	30° Asymmetrical	63016489	20	1033	1248
04442202	222-60-TH-208V	04444602	222-60-THSS-208V	3.2	10,922	208	60° Symmetrical	63016209	20	1033	1248
04442302	222-60-TH-240V	04444702	222-60-THSS-240V	3.2	10,922	240	60° Symmetrical	63016249	20	1033	1248
04442402	222-60-TH-277V	04444802	222-60-THSS-277V	3.2	10,922	277	60° Symmetrical	63016279	20	1033	1248
04813902	222-60-TH-480V	04814402	222-60-THSS-480V	3.2	10,922	480	60° Symmetrical	63016489	20	1033	1248
04442502	222-A60-TH-208V	04444902	222-A60-THSS-208V	3.2	10,922	208	60° Asymmetrical	63016209	20	1033	1248
04442602	222-A60-TH-240V	04445002	222-A60-THSS-240V	3.2	10,922	240	60° Asymmetrical	63016249	20	1033	1248
04442702	222-A60-TH-277V	04445102	222-A60-THSS-277V	3.2	10,922	277	60° Asymmetrical	63016279	20	1033	1248
04814202	222-A60-TH-480V	04814702	222-A60-THSS-480V	3.2	10,922	480	60° Asymmetrical	63016489	20	1033	1248
04432902	222-90-TH-208V	04445202	222-90-THSS-208V	3.2	10,922	208	90° Symmetrical	63016209	20	1033	1248
04442802	222-90-TH-240V	04445302	222-90-THSS-240V	3.2	10,922	240	90° Symmetrical	63016249	20	1033	1248
04442902	222-90-TH-277V	04445402	222-90-THSS-277V	3.2	10,922	277	90° Symmetrical	63016279	20	1033	1248
04814002	222-90-TH-480V	04814502	222-90-THSS-480V	3.2	10,922	480	90° Symmetrical	63016489	20	1033	1248
04810802	342-30-TH-208V	04809302	342-30-THSS-208V	5.0	17,065	208	30° Symmetrical	63025209	25	1361	1743
04810902	342-30-TH-240V	04809402	342-30-THSS-240V	5.0	17,065	240	30° Symmetrical	63025249	25	1361	1743
88026143	342-30-TH-480V	88026394	342-30-THSS-480V	5.0	17,065	480	30° Symmetrical	63025489	25	1361	1743
04811702	342-A30-TH-208V	04810202	342-A30-THSS-208V	5.0	17,065	208	30° Asymmetrical	63025209	25	1361	1743
04811802	342-A30-TH-240V	04810302	342-A30-THSS-240V	5.0	17,065	240	30° Asymmetrical	63025249	25	1361	1743
04443102	342-A30-TH-480V	04445602	342-A30-THSS-480V	5.0	17,065	480	30° Asymmetrical	63025489	25	1361	1743
04811102	342-60-TH-208V	---	---	5.0	17,065	208	60° Symmetrical	63025209	25	1361	1743
04811202	342-60-TH-240V	04809702	342-60-THSS-240V	5.0	17,065	240	60° Symmetrical	63025249	25	1361	1743
88029143	342-60-TH-480V	88029394	342-60-THSS-480V	5.0	17,065	480	60° Symmetrical	63025489	25	1361	1743
04812002	342-A60-TH-208V	04810502	342-A60-THSS-208V	5.0	17,065	208	60° Asymmetrical	63025209	25	1361	1743
04812102	342-A60-TH-240V	04810602	342-A60-THSS-240V	5.0	17,065	240	60° Asymmetrical	63025249	25	1361	1743
04443302	342-A60-TH-480V	04445802	342-A60-THSS-480V	5.0	17,065	480	60° Asymmetrical	63025489	25	1361	1743
04811402	342-90-TH-208V	04809902	342-90-THSS-208V	5.0	17,065	208	90° Symmetrical	63025209	25	1361	1743
04811502	342-90-TH-240V	04810002	342-90-THSS-240V	5.0	17,065	240	90° Symmetrical	63025249	25	1361	1743
88032144	342-90-TH-480V	88032394	342-90-THSS-480V	5.0	17,065	480	90° Symmetrical	63025489	25	1361	1743
88027143	462-30-TH-480V	88027393	462-30-THSS-480V	5.0	24,915	480	30° Symmetrical	63036489	32	1711	2096
04443602	462-A30-TH-480V	04446102	462-A30-THSS-480V	5.0	24,915	480	30° Asymmetrical	63036489	32	1711	2096
88030143	462-60-TH-480V	88030393	462-60-THSS-480V	7.3	24,915	480	60° Symmetrical	63036489	32	1711	2096
04443802	462-A60-TH-480V	04446302	462-A60-THSS-480V	7.3	24,915	480	60° Asymmetrical	63036489	32	1711	2096
88033144	462-90-TH-480V	88033394	462-90-THSS-480V	7.3	24,915	480	90° Symmetrical	63036489	32	1711	2096

NOTE: Consult the factory, the product instruction manual, or a licensed electrician for 3-phase wiring of all 2-element heaters.

TH-AG & THSS-AG Series Mul-T-Mount Electric Infrared Heaters

3-Lamp Mul-T-Mount Series Bankers Bronze Or Stainless Steel
With (3) Clear 8mm Quartz Lamps and Amber Gray Sleeves Included

- Heaters shipped with glare-reducing sleeves & elements included
- Asymmetrical pattern units are also available for 30° & 60°
- Made in U.S.A.



⚠ WARNING: This product can expose you to chemicals including nickel which is known to the State of California to cause cancer, and chromium, which is known to the State of California to cause birth defects and/or reproductive harm. For more information go to www.P65Warnings.ca.gov.



BRONZE HOUSING		STAINLESS STEEL HOUSING		KW	BTUs	VOLTS	REFLECTOR PATTERN	8mm DIAMETER REPL. LAMP	WT. (LBS)	LIST	
MFG CATALOG NUMBER	MFG MODEL NUMBER	MFG CATALOG NUMBER	MFG MODEL NUMBER							Bankers Bronze	Stainless Steel
04908002	223-30-TH-208V-AG	04910402	223-30-THSS-208V-AG	4.8	16382	208	30° Sym.	04912802	25	1876	2112
04908102	223-30-TH-240V-AG	04910502	223-30-THSS-240V-AG	4.8	16382	240	30° Sym.	04912902	25	1876	2112
04908202	223-30-TH-277V-AG	04910602	223-30-THSS-277V-AG	4.8	16382	277	30° Sym.	04913002	25	1876	2112
04908302	223-30-TH-480V-AG	04910702	223-30-THSS-480V-AG	4.8	16382	480	30° Sym.	04913102	25	1876	2112
04908402	223-60-TH-208V-AG	04910802	223-60-THSS-208V-AG	4.8	16382	208	60° Sym.	04912802	25	1876	2112
04908502	223-60-TH-240V-AG	04910902	223-60-THSS-240V-AG	4.8	16382	240	60° Sym.	04912902	25	1876	2112
04908602	223-60-TH-277V-AG	04911002	223-60-THSS-277V-AG	4.8	16382	277	60° Sym.	04913002	25	1876	2112
04908702	223-60-TH-480V-AG	04911102	223-60-THSS-480V-AG	4.8	16382	480	60° Sym.	04913102	25	1876	2112
04908802	223-90-TH-208V-AG	04911202	223-90-THSS-208V-AG	4.8	16382	208	90° Sym.	04912802	25	1876	2112
04908902	223-90-TH-240V-AG	04911302	223-90-THSS-240V-AG	4.8	16382	240	90° Sym.	04912902	25	1876	2112
04909002	223-90-TH-277V-AG	04911402	223-90-THSS-277V-AG	4.8	16382	277	90° Sym.	04913002	25	1876	2112
04909102	223-90-TH-480V-AG	04911502	223-90-THSS-480V-AG	4.8	16382	480	90° Sym.	04913102	25	1876	2112
04909202	343-30-TH-208V-AG	04911602	343-30-THSS-208V-AG	7.5	25298	208	30° Sym.	04913202	33	2105	2694
04909302	343-30-TH-240V-AG	04911702	343-30-THSS-240V-AG	7.5	25298	240	30° Sym.	04913302	33	2105	2694
04909402	343-30-TH-480V-AG	04911802	343-30-THSS-480V-AG	7.5	25298	480	30° Sym.	04913502	33	2105	2694
04909502	343-60-TH-208V-AG	04911902	343-60-THSS-208V-AG	7.5	25298	208	60° Sym.	04913202	33	2105	2694
04909602	343-60-TH-240V-AG	04912002	343-60-THSS-240V-AG	7.5	25298	240	60° Sym.	04913302	33	2105	2694
04909702	343-60-TH-480V-AG	04912102	343-60-THSS-480V-AG	7.5	25298	480	60° Sym.	04913502	33	2105	2694
04909802	343-90-TH-208V-AG	04912202	343-90-THSS-208V-AG	7.5	25298	208	90° Sym.	04913202	33	2105	2694
04909902	343-90-TH-240V-AG	04912302	343-90-THSS-240V-AG	7.5	25298	240	90° Sym.	04913302	33	2105	2694
04910002	343-90-TH-480V-AG	04912402	343-90-THSS-480V-AG	7.5	25298	480	90° Sym.	04913502	33	2105	2694
04910102	463-30-TH-480V-AG	04912502	463-30-THSS-480V-AG	10.95	37372	480	30° Sym.	04913602	41	2724	3156
04910202	463-60-TH-480V-AG	04912602	463-60-THSS-480V-AG	10.95	37372	480	60° Sym.	04913602	41	2724	3156
04910302	463-90-TH-480V-AG	04912702	463-90-THSS-480V-AG	10.95	37372	480	90° Sym.	04913602	41	2724	3156



96% RADIANT EFFICIENCY



NO OPEN FLAMES



NO HARMFUL FUMES



NO MOVING PARTS



NO NOISE

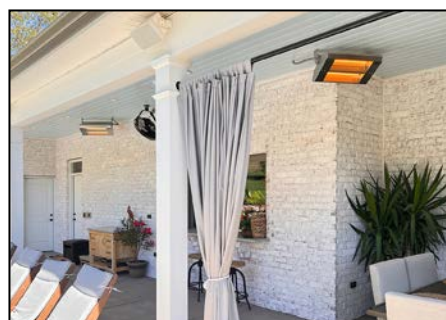

TH-AG & THSS-AG Series Mul-T-Mount Electric Infrared Heaters



2-Lamp Mul-T-Mount Series Bankers Bronze Or Stainless Steel
With (2) Clear 8mm Quartz Lamps and Amber Gray Sleeves Included

BRONZE HOUSING		STAINLESS STEEL HOUSING		KW	BTUs	VOLTS	A-SYM REFLECTOR PATTERN	8mm DIAMETER REPL. LAMP	WT. (LBS)	LIST	
MFG CATALOG NUMBER	MFG MODEL NUMBER	MFG CATALOG NUMBER	MFG MODEL NUMBER							Bankers Bronze	Stainless Steel
04900002	222-30-TH-208V-AG	04904002	222-30-THSS-208V-AG	3.2	10922	208	30° Sym.	04912802	20	1138	1378
04900102	222-30-TH-240V-AG	04904102	222-30-THSS-240V-AG	3.2	10922	240	30° Sym.	04912902	20	1138	1378
04900202	222-30-TH-277V-AG	04904202	222-30-THSS-277V-AG	3.2	10922	277	30° Sym.	04913002	20	1138	1378
04900302	222-30-TH-480V-AG	04904302	222-30-THSS-480V-AG	3.2	10922	480	30° Sym.	04913102	20	1138	1378
04900402	222-A30-TH-208V-AG	04904402	222-A30-THSS-208V-AG	3.2	10922	208	30° ASym.	04912802	20	1138	1378
04900502	222-A30-TH-240V-AG	04904502	222-A30-THSS-240V-AG	3.2	10922	240	30° ASym.	04912902	20	1138	1378
04900602	222-A30-TH-277V-AG	04904602	222-A30-THSS-277V-AG	3.2	10922	277	30° ASym.	04913002	20	1138	1378
04900702	222-A30-TH-480V-AG	04904702	222-A30-THSS-480V-AG	3.2	10922	480	30° ASym.	04913102	20	1138	1378
04900802	222-60-TH-208V-AG	---	---	3.2	10922	208	60° Sym.	04912802	20	1138	1378
04900902	222-60-TH-240V-AG	04904902	222-60-THSS-240V-AG	3.2	10922	240	60° Sym.	04912902	20	1138	1378
04901002	222-60-TH-277V-AG	04905002	222-60-THSS-277V-AG	3.2	10922	277	60° Sym.	04913002	20	1138	1378
04901102	222-60-TH-480V-AG	04905102	222-60-THSS-480V-AG	3.2	10922	480	60° Sym.	04913102	20	1138	1378
04901202	222-A60-TH-208V-AG	04905202	222-A60-THSS-208V-AG	3.2	10922	208	60° ASym.	04912802	20	1138	1378
04901302	222-A60-TH-240V-AG	04905302	222-A60-THSS-240V-AG	3.2	10922	240	60° ASym.	04912902	20	1138	1378
04901402	222-A60-TH-277V-AG	04905402	222-A60-THSS-277V-AG	3.2	10922	277	60° ASym.	04913002	20	1138	1378
04901502	222-A60-TH-480V-AG	04905502	222-A60-THSS-480V-AG	3.2	10922	480	60° ASym.	04913102	20	1138	1378
04901602	222-90-TH-208V-AG	04905602	222-90-THSS-208V-AG	3.2	10922	208	90° Sym.	04912802	20	1138	1378
04901702	222-90-TH-240V-AG	04905702	222-90-THSS-240V-AG	3.2	10922	240	90° Sym.	04912902	20	1138	1378
04901802	222-90-TH-277V-AG	04905802	222-90-THSS-277V-AG	3.2	10922	277	90° Sym.	04913002	20	1138	1378
04901902	222-90-TH-480V-AG	04905902	222-90-THSS-480V-AG	3.2	10922	480	90° Sym.	04913102	20	1138	1919
04902002	342-30-TH-208V-AG	04906002	342-30-THSS-208V-AG	5.0	17065	208	30° Sym.	04913202	20	1498	1919
04902102	342-30-TH-240V-AG	04906102	342-30-THSS-240V-AG	5.0	17065	240	30° Sym.	04913302	25	1498	1919
04902202	342-30-TH-480V-AG	04906202	342-30-THSS-480V-AG	5.0	17065	480	30° Sym.	04913502	25	1498	1919
04902302	342-A30-TH-208V-AG	04906302	342-A30-THSS-208V-AG	5.0	17065	208	30° A-Sym.	04913202	25	1498	1919
04902402	342-A30-TH-240V-AG	04906402	342-A30-THSS-240V-AG	5.0	17065	240	30° A-Sym.	04913302	25	1498	1919
04902502	342-A30-TH-480V-AG	04906502	342-A30-THSS-480V-AG	5.0	17065	480	30° A-Sym.	04913502	25	1498	1919
04902602	342-60-TH-208V-AG	04906602	342-60-THSS-208V-AG	5.0	17065	208	60° Sym.	04913202	25	1498	1919
04902702	342-60-TH-240V-AG	04906702	342-60-THSS-240V-AG	5.0	17065	240	60° Sym.	04913302	25	1498	1919
04902802	342-60-TH-480V-AG	04906802	342-60-THSS-480V-AG	5.0	17065	480	60° Sym.	04913502	25	1498	1919
04902902	342-A60-TH-208V-AG	04906902	342-A60-THSS-208V-AG	5.0	17065	208	60° ASym.	04913202	25	1498	1919
04903002	342-A60-TH-240V-AG	04907002	342-A60-THSS-240V-AG	5.0	17065	240	60° ASym.	04913302	25	1498	1919
04903102	342-A60-TH-480V-AG	04907102	342-A60-THSS-480V-AG	5.0	17065	480	60° ASym.	04913502	25	1498	1919
04903202	342-90-TH-208V-AG	04907202	342-90-THSS-208V-AG	5.0	17065	208	90° Sym.	04913202	25	1498	1919
04903302	342-90-TH-240V-AG	04907302	342-90-THSS-240V-AG	5.0	17065	240	90° Sym.	04913302	25	1498	1919
04903402	342-90-TH-480V-AG	04907402	342-90-THSS-480V-AG	5.0	17065	480	90° Sym.	04913502	25	1498	2305
04903502	462-30-TH-480V-AG	04907502	462-30-THSS-480V-AG	7.3	24915	480	30° Sym.	04913602	25	1882	2305
04903602	462-A30-TH-480V-AG	04907602	462-A30-THSS-480V-AG	7.3	24915	480	30° ASym.	04913602	32	1882	2305
04903702	462-60-TH-480V-AG	04907702	462-60-THSS-480V-AG	7.3	24915	480	60° Sym.	04913602	32	1882	2305
04903802	462-A60-TH-480V-AG	04907802	462-A60-THSS-480V-AG	7.3	24915	480	60° ASym.	04913602	32	1882	2305
04903902	462-90-TH-480V-AG	04907902	462-90-THSS-480V-AG	7.3	24915	480	90° Sym.	04913602	32	1882	2305

NOTE: Consult the factory, the product instruction manual, or a licensed electrician for 3-phase wiring of all 2-element heaters.

THA Series Architectural Mul-T-Mount Electric Infrared Heaters

3-Lamp Mul-T-Mount Series - Nickel Gray Housing With (3) Clear 8mm Quartz Lamps and Amber Gray Sleeves Included



Heavy Duty Extruded Aluminum Housing

Glare Reduction Element & Sleeve
Combination Heater Series

- ETL C/US listed for suspended, totally exposed outdoor and indoor spot comfort heating applications, including exterior snow/ice control applications
- Clear quartz lamp heating elements, offered in both 2-lamp and 3-lamp heaters that operate on 208, 240, or 480 volt
- Gold anodized one-piece reflector offered in 30°, 60°, or 90° symmetrical patterns for various distribution of infrared heat
- 6063 extruded aluminum housing, with a painted powder coated nickel gray finish
- Housing is extremely durable and attractively designed for commercial applications
- All 3-lamp heaters wire for either single or three-phase wiring.
- 2-lamp heaters wire for single-phase operation
- Includes surface mounting brackets & glare reducing sleeves to eliminate 94% of the quartz lamp lumen output
- Made in the USA

NICKEL GRAY HOUSING		KW	BTUs	VOLTS	REFLECTOR PATTERN	8mm DIAMETER REPLACEMENT LAMP	WT. (LBS)	LIST
MFG CATALOG NUMBER	MFG MODEL NUMBER							
04896202	223-30-THA-208V	4.8	16,382	208	30° Symmetrical	04912802	25	2170
04896302	223-30-THA-240V	4.8	16,382	240	30° Symmetrical	04912902	25	2170
04896402	223-30-THA-277V	4.8	16,382	277	30° Symmetrical	04913002	25	2170
04896502	223-30-THA-480V	4.8	16,382	480	30° Symmetrical	04913102	25	2170
04896602	223-60-THA-208V	4.8	16,382	208	60° Symmetrical	04912802	25	2170
04896702	223-60-THA-240V	4.8	16,382	240	60° Symmetrical	04912902	25	2170
04896802	223-60-THA-277V	4.8	16,382	277	60° Symmetrical	04913002	25	2170
04896902	223-60-THA-480V	4.8	16,382	480	60° Symmetrical	04913102	25	2170
04897002	223-90-THA-208V	4.8	16,382	208	90° Symmetrical	04912802	25	2170
04897102	223-90-THA-240V	4.8	16,382	240	90° Symmetrical	04912902	25	2170
04897202	223-90-THA-277V	4.8	16,382	277	90° Symmetrical	04913002	25	2170
04897302	223-90-THA-480V	4.8	16,382	480	90° Symmetrical	04913102	25	2170
04897402	343-30-THA-208V	7.5	25,298	208	30° Symmetrical	04913202	33	2545
04897502	343-30-THA-240V	7.5	25,298	240	30° Symmetrical	04913302	33	2545
04897602	343-30-THA-480V	7.5	25,298	480	30° Symmetrical	04913502	33	2545
04897702	343-60-THA-208V	7.5	25,298	208	60° Symmetrical	04913202	33	2545
04897802	343-60-THA-240V	7.5	25,298	240	60° Symmetrical	04913302	33	2545
04897902	343-60-THA-480V	7.5	25,298	480	60° Symmetrical	04913502	33	2545
04898002	343-90-THA-208V	7.5	25,298	208	90° Symmetrical	04913202	33	2545
04898102	343-90-THA-240V	7.5	25,298	240	90° Symmetrical	04913302	33	2545
04898202	343-90-THA-480V	7.5	25,298	480	90° Symmetrical	04913502	33	2545
04898302	463-30-THA-480V	10.95	37,372	480	30° Symmetrical	04913602	41	2949
04898402	463-60-THA-480V	10.95	37,372	480	60° Symmetrical	04913602	41	2949
04898502	463-90-THA-480V	10.95	37,372	480	90° Symmetrical	04913602	41	2949

NOTE:

- All THA models have the same housing dimensions and require the same mounting clearances as the TH/THSS models; see page 79
- See page 81 for sizing chart information
- Asymmetrical pattern units are also available for 30° & 60°, contact factory for more information



WARNING: This product can expose you to chemicals including nickel which is known to the State of California to cause cancer, and chromium, which is known to the State of California to cause birth defects and/or reproductive harm. For more information go to www.P65Warnings.ca.gov.

2-Lamp Mul-T-Mount Series - Nickel Gray Housing With (2) Clear 8mm Quartz Lamps and Amber Gray Sleeves Included

- ETL C/US listed for suspended, totally exposed outdoor and indoor spot comfort heating applications, including exterior snow/ice control applications
- Clear quartz lamp heating elements, 2-lamp housings operating on 208, 240, 277 or 480 volt
- Gold anodized one-piece reflector offered in 30°, 60°, or 90°symmetrical patterns for various distribution of infrared heat
- 6063 extruded aluminum housing, with a painted powder coated nickel gray finish
- Durable and attractively designed housing, ideal for commercial applications
- 2-lamp heaters wire for single-phase operation
- Includes surface mounting brackets & glare reducing sleeves to eliminate 94% of the quartz lamp lumen output
- Made in the USA

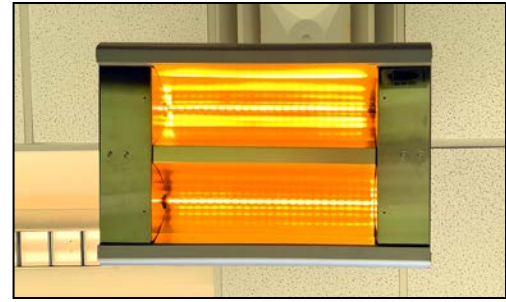

Heavy Duty Extruded Aluminum Housing
Glare Reduction Element & Sleeve
Combination Heater Series

NICKEL GRAY HOUSING		KW	BTUs	VOLTS	REFLECTOR PATTERN	8mm DIAMETER REPLACEMENT LAMP	WT. (LBS)	LIST
MFG CATALOG NUMBER	MFG MODEL NUMBER							
04892202	222-30-THA-208V	3.2	10,922	208	30° Symmetrical	04912802	20	1332
04892302	222-30-THA-240V	3.2	10,922	240	30° Symmetrical	04912902	20	1332
04892402	222-30-THA-277V	3.2	10,922	277	30° Symmetrical	04913002	20	1332
04892502	222-30-THA-480V	3.2	10,922	480	30° Symmetrical	04913102	20	1332
04892602	222-A30-THA-208V	3.2	10,922	208	30° Asymmetrical	04912802	20	1332
04892702	222-A30-THA-240V	3.2	10,922	240	30° Asymmetrical	04912902	20	1332
04892802	222-A30-THA-277V	3.2	10,922	277	30° Asymmetrical	04913002	20	1332
04892902	222-A30-THA-480V	3.2	10,922	480	30° Asymmetrical	04913102	20	1332
04893002	222-60-THA-208V	3.2	10,922	208	60° Symmetrical	04912802	20	1332
04893102	222-60-THA-240V	3.2	10,922	240	60° Symmetrical	04912902	20	1332
04893202	222-60-THA-277V	3.2	10,922	277	60° Symmetrical	04913002	20	1332
04893302	222-60-THA-480V	3.2	10,922	480	60° Symmetrical	04913102	20	1332
04893402	222-A60-THA-208V	3.2	10,922	208	60° Asymmetrical	04912802	20	1332
04893502	222-A60-THA-240V	3.2	10,922	240	60° Asymmetrical	04912902	20	1332
04893602	222-A60-THA-277V	3.2	10,922	277	60° Asymmetrical	04913002	20	1332
04893702	222-A60-THA-480V	3.2	10,922	480	60° Asymmetrical	04913102	20	1332
04893802	222-90-THA-208V	3.2	10,922	208	90° Symmetrical	04912802	20	1332
04893902	222-90-THA-240V	3.2	10,922	240	90° Symmetrical	04912902	20	1332
04894002	222-90-THA-277V	3.2	10,922	277	90° Symmetrical	04913002	20	1332
04894102	222-90-THA-480V	3.2	10,922	480	90° Symmetrical	04913102	20	1332
04894202	342-30-THA-208V	5	17,065	208	30° Symmetrical	04913202	25	1819
04894302	342-30-THA-240V	5	17,065	240	30° Symmetrical	04913302	25	1819
04894402	342-30-THA-480V	5	17,065	480	30° Symmetrical	04913502	25	1819
04894502	342-A30-THA-208V	5	17,065	208	30° Asymmetrical	04913202	25	1819
04894602	342-A30-THA-240V	5	17,065	240	30° Asymmetrical	04913302	25	1819
04894702	342-A30-THA-480V	5	17,065	480	30° Asymmetrical	04913502	25	1819
04894802	342-60-THA-208V	5	17,065	208	60° Symmetrical	04913202	25	1819
04894902	342-60-THA-240V	5	17,065	240	60° Symmetrical	04913302	25	1819
04895002	342-60-THA-480V	5	17,065	480	60° Symmetrical	04913502	25	1819
04895102	342-A60-THA-208V	5	17,065	208	60° Asymmetrical	04913202	25	1819
04895202	342-A60-THA-240V	5	17,065	240	60° Asymmetrical	04913302	25	1819
04895302	342-A60-THA-480V	5	17,065	480	60° Asymmetrical	04913502	25	1819
04895402	342-90-THA-208V	5	17,065	208	90° Symmetrical	04913202	25	1819
04895502	342-90-THA-240V	5	17,065	240	90° Symmetrical	04913302	25	1819
04895602	342-90-THA-480V	5	17,065	480	90° Symmetrical	04913502	25	1819
04895702	462-30-THA-480V	7.3	24,915	480	30° Symmetrical	04913602	32	2187
04895802	462-A30-THA-480V	7.3	24,915	480	30° Asymmetrical	04913602	32	2187
04895902	462-60-THA-480V	7.3	24,915	480	60° Symmetrical	04913602	32	2187
04896002	462-A60-THA-480V	7.3	24,915	480	60° Asymmetrical	04913602	32	2187
04896102	462-90-THA-480V	7.3	24,915	480	90° Symmetrical	04913602	32	2187

NOTE: Consult the factory, the product instruction manual, or a licensed electrician for 3-phase wiring of all 2-element heaters.

Mul-T-Mount Electric Infrared Heater - Accessories

TH & THSS Series Recessing Mounting Frames

MFG CATALOG NUMBER	MFG MODEL NUMBER	DESCRIPTION		FOR USE WITH	WT.(LBS)	LIST
		Ceiling Cutout (in.)	Frame Size (in.)			
04419902	RMF-222-SS-A	27 x 17 7/8	29 1/8 x 20	222 Series Stainless	6	387
04494402	RMF-222-A	27 x 17 7/8	29 1/8 x 20	222 Series Painted	6	282
04420702	RMF-342-SS-A	36 x 17 7/8	38 1/8 x 20	342 Series Stainless	9	476
04418702	RMF-342-A	36 x 17 7/8	38 1/8 x 20	342 Series Painted	9	284
04421002	RMF-462-SS-A	49 x 17 7/8	51 1/8 x 20	462 Series Stainless	11	581
04494502	RMF-462-A	49 x 17 7/8	51 1/8 x 20	462 Series Painted	11	360
08811002	RMF-223-SS	32 x 29 3/8	34 1/8 x 31 1/2	223 Series Stainless	15	555
08811302	RMF-343-SS	41 x 29 3/8	43 1/8 x 31 1/2	343 Series Stainless	18	652
08811102	RMF-463-SS	54 x 29 3/8	56 1/8 x 31 1/2	463 Series Stainless	20	652
04877202	RMF-223	32 x 29 3/8	34 1/8 x 31 1/2	223 Series Painted	15	469
04877302	RMF-343	41 x 29 3/8	43 1/8 x 31 1/2	343 Series Painted	18	494
04877402	RMF-463	54 x 29 3/8	56 1/8 x 31 1/2	463 Series Painted	20	613
04407802	31939009	Red Vycor Sleeves Reduces 12mm Clear Quartz Lamp Brightness by 90%		All 1600W Qtz. Lamp	2	147
04407302	31940009			All 2500W Qtz. Lamp	2	195
04407402	31941009			All 3650W Qtz. Lamp	2	239
04461502	632-1620	Red Quartz Lamps; 1.6kw, 208v		222, 223 & RPH Series	2	243
04461602	632-1624	Red Quartz Lamps; 1.6kw, 240v		222, 223 & RPH Series	2	243
04462202	632-2548	Red Quartz Lamps; 2.5kw, 480v		342 & 343 Series	2	284



Recessed frame sold separately.
(NOTE: THA Series can not be recessed)

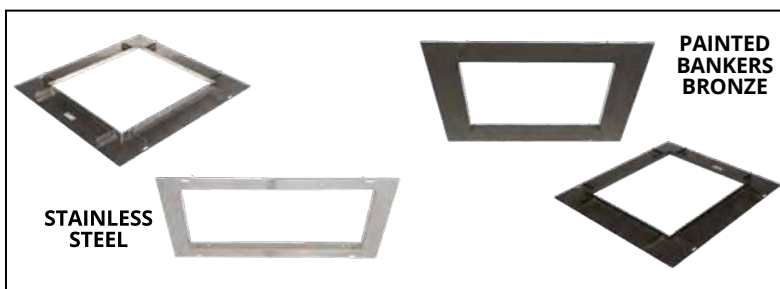

Wall Mounting Bracket for TH/THSS or THA Heaters -Stainless Steel (Pair)

MFG CATALOG NUMBER	MFG MODEL NUMBER	DESCRIPTION	FOR USE WITH	WT. (LBS)	LIST
08811239	VMB-41-SS	Wall Mounting Brackets (2)	All Mul-T-Mount Models	12	350



VMB - Vertical Mounting Bracket (pair)

Stainless steel material provides a 3' necessary clearance from a vertical surface.



WARNING: This product can expose you to chemicals including nickel which is known to the State of California to cause cancer, and chromium, which is known to the State of California to cause birth defects and/or reproductive harm. For more information go to www.P65Warnings.ca.gov.

Protective Guard for TH/THSS or THA Heaters - Stainless Steel (Pair)

MFG CATALOG NUMBER	MFG MODEL NUMBER	DESCRIPTION	FOR USE WITH	WT. (LBS)	LIST
08511500	CHWG-222	Stainless steel wire guards with retaining clips and hardware	222 Series	2	95
08511400	CHWG-342		342 Series	3	126
08516200	CHWG-462		462 Series	4	171
08543600	CHWG-223		223 Series	2	117
08543500	CHWG-343		343 Series	3	152
08543400	CHWG-463		463 Series	4	177
04898602	THA222 GUARD	Stainless steel wire guards with fasteners	222 THA Series	2	97
04898702	THA223 GUARD		223 THA Series	2	97
04898802	THA342 GUARD		342 THA Series	3	130
04898902	THA343 GUARD		343 THA Series	3	130
04899002	THA462 GUARD		462 THA Series	4	181
04899102	THA463 GUARD		463 THA Series	4	181

TH & THSS Series Replacement Quartz Lamps

MFG CATALOG NUMBER	MFG MODEL NUMBER	WATTS	VOLTS	LENGTH (IN.)		ENVELOPE TYPE	FITS MODEL	LIST
				Overall	Heated			
04400502	630-05129	500	120	8 1/16	5	12mm CLEAR	MM-13A	175
04401602	630-16209	1600	208	19 1/16	16	12mm CLEAR	222, 223, or MM-24A	206
04401702	630-16249	1600	240	19 1/16	16	12mm CLEAR	222, 223, or MM-24A	206
04409902	631-16249	1600	240	19 1/16	16	12mm CLEAR	222, 223, or MM-24A	249
04401802	630-16279	1600	277	19 1/16	16	12mm CLEAR	222, 223, or MM-24A	200
04817302	630-16489	1600	480	19 1/16	16	12mm CLEAR	222, 223, or MM-24A	249
04817402	630-25209	2500	208	28 1/16	25	12mm CLEAR	342, 343, or MM-33A	292
04817502	630-25249	2500	240	28 1/16	25	12mm CLEAR	342, 343, or MM-33A	292
04817602	630-25279	2500	277	28 1/16	25	12mm CLEAR	342, 343, or MM-33A	318
04405402	630-25489	2500	480	28 1/16	25	12mm CLEAR	342, 343, or MM-33A	259
04403602	631-25489	2500	480	28 1/16	25	12mm CLEAR	342, 343, or MM-33A	273
04406802	631-25609	2500	600	28 1/16	25	12mm CLEAR	342, 343, or MM-33A	281
04406702	630-36489	3650	480	41 1/16	38	12mm CLEAR	462, 463, or MM-46A	384
04462302	630-38579	3800	577	41 1/16	38	12mm CLEAR	462, 463, or MM-46A	384
04441302	631-38579	3800	577	41 1/16	38	12mm CLEAR	462, 463, or MM-46A	393
04914602	632-15129	1500	120	19 1/16	16	12mm CLEAR	222/223 or RPH	243
04461502	632-16209	1600	208	19 1/16	16	12mm RED or RPH	222/223 or RPH	243
04461602	632-16249	1600	240	19 1/16	16	12mm RED or RPH	222/223 or RPH	243
04462202	632-25489	2500	480	28 1/16	25	12mm RED or RPH	342 or 343	284

04912802	59129101	1600	208	19 1/16	16	8mm CLEAR	222 or 223	206
04912902	59129102	1600	240	19 1/16	16	8mm CLEAR	222 or 223	206
04913002	59129103	1600	277	19 1/16	16	8mm CLEAR	222 or 223	206
04913102	59129104	1600	480	19 1/16	16	8mm CLEAR	222 or 223	249
04913202	59129105	2500	208	28 1/16	25	8mm CLEAR	342 or 343	292
04913302	59129106	2500	240	28 1/16	25	8mm CLEAR	342 or 343	292
04913402	59129107	2500	277	28 1/16	25	8mm CLEAR	342 or 343	326
04913502	59129108	2500	480	28 1/16	25	8mm CLEAR	342 or 343	281
04913602	59129109	3650	480	41 1/16	38	8mm CLEAR	462 or 463	384

- Quartz infrared electric heating element - short wavelength.
- Coiled tungsten filament; sealed porcelain end caps; halogen gas filled.
- Color temperature emitted: approx. 4100°F (high brightness)
- Approximately 96% radiant efficiency
- Reaches full operating temperature in less than 60-seconds
- 8-lumens/watt-generates a warm bright light color
- Excellent resistance to thermal shock and is rated for both outdoor and indoor heating applications.
- Includes 6" wire leads for quick installation.
- Quartz envelope of Clear or Red elements measure 3/16" in diameter (12mm); 591-Series is 8mm in diameter

Clear Quartz Lamps 630 or 631- Series Wire Termination



Red Quartz Lamps 632 - Series Wire Termination



NOTE: Model #
630 = Horizontal Burning "Clear" 12MM
631 = Vertical OR Horizontal Burning "Clear" 12MM
632 = Horizontal Burning "Red" 12MM
591 = Horizontal Burning "Clear" 8MM

Glare Reduction Sleeves for TH/THSS or THA Heaters - Ruby Red & Amber Gray

MFG CATALOG NUMBER	MFG MODEL NUMBER	DESCRIPTION	WT. (LBS)	LIST
04407802	31939009	Red Vycor Sleeves reduces 12mm Clear Quartz Lamp brightness by 90%	1600W Qtz. Lamps	2 147
04407302	31940009		2500W Qtz. Lamps	2 195
04407402	31941009		3650W Qtz. Lamps	2 239
04891102	59111102	Amber Gray Sleeves reduces 8mm Clear Quartz Lamp brightness by 90%	1600W Qtz. Lamps	2 147
04891202	59111103		2500W Qtz. Lamps	2 195
04891302	59111106		3650W Qtz. Lamps	2 239

MFG CATALOG NUMBER	MFG MODEL NUMBER	DESCRIPTION	WT. (LBS)	LIST
04899202	AGS1620	1600 W 208 V 8mm AMBER GRAY SLEEVE / LAMP KIT	5	341
04899302	AGS1624	1600 W 240 V 8mm AMBER GRAY SLEEVE / LAMP KIT	5	341
04899402	AGS1627	1600 W 277 V 8mm AMBER GRAY SLEEVE / LAMP KIT	5	341
04899502	AGS1648	1600 W 480 V 8mm AMBER GRAY SLEEVE / LAMP KIT	5	402
04899602	AGS2520	2500 W 208 V 8mm AMBER GRAY SLEEVE / LAMP KIT	8	508
04899702	AGS2524	2500 W 240 V 8mm AMBER GRAY SLEEVE / LAMP KIT	8	508
04899802	AGS2548	2500 W 480 V 8mm AMBER GRAY SLEEVE / LAMP KIT	8	508
04899902	AGS3648	3650 W 480 V 8mm AMBER GRAY SLEEVE / LAMP KIT	8	617

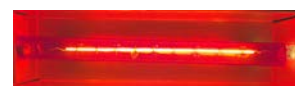

Ruby Red Sleeve



Amber Gray Sleeve



OPTIONAL 8MM AMBER GRAY SLEEVE / LAMP KIT

(kits can be used as replacements for any existing Mul-T-Mount fixture)
 Note: 2-lamp fixtures require 2 kits; 3-lamp fixtures require 3 kits; 600 Volt models not available

FSS Series Heavy Duty Flat Panel Emitter Electric Overhead Infrared Heater

Heavy Duty Overhead Infrared Heaters for Indoor Spot Heating, Zone, or Total Area Heating Applications

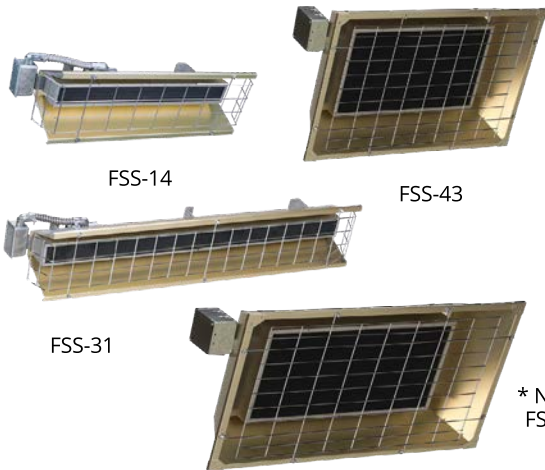

* NEW *
FSS-65

- High-density, medium wavelength radiant heat, with 60° symmetric heat pattern
- Flat panel emitter operates at a radiant efficiency of 78.5%
- Non-glare, uniform heat generating directional heat pattern
- Rugged steel structure surrounds emitter element, great for high vibration areas
- Gold anodized aluminum housing for efficient, long term reflectivity & corrosion resistance
- Single or three phase wiring on select models
- "L" brackets included for chain suspension, or rigid mounting
- Field wiring box mounted on each heater
- Heavy duty wire guard factory installed
- 25,000 hour element life expectancy
- Shipped fully assembled
- Made in U.S.A.

Standard Models

MFG CATALOG NUMBER	MFG MODEL NUMBER	VOLTS	WATTS	BTU's	AMPS		ELEMENTS PER HEATER	WT (LBS.)	LIST
					1-PH	3-PH			
04881502	FSS-1412-1	120	1450	4947	12.1		1	7	1279
04881602	FSS-1420-1	208	1450	4947	6.97			7	1279
04881702	FSS-1424-1	240	1450	4947	6.04			7	1279
04881802	FSS-1427-1	277	1450	4947	5.25			7	1279
04881902	FSS-1448-1	480	1450	4947	3.02			7	1279
04882002	FSS-1457-1	600	1450	4947	2.52			7	1279
04882102	FSS-3120-1	208	3150	10784	15.14			13	1588
04882202	FSS-3124-1	240	3150	10784	13.13			13	1588
04882302	FSS-3127-1	277	3150	10784	11.37			13	1588
04882402	FSS-3148-1	480	3150	10784	6.56			13	1588
04882502	FSS-3157-1	600	3150	10784	5.48			13	1588
04882602	FSS-4320-3	208	4300	14672	20.67	11.94		18	1943
04882702	FSS-4324-3	240	4300	14672	17.91	10.36		18	1943
04882802	FSS-4327-1	277	4300	14672	15.52			18	1943
04882902	FSS-4348-3	480	4300	14672	8.96	5.18		18	1943
04883002	FSS-4357-3	600	4300	14672	7.48	4.32		18	1943
04926202	FSS-6520-3	208	6500	22178	31.3	17.1		28	2198
04926302	FSS-6524-3	240	6500	22178	27.1	15.7		28	2198
04926402	FSS-6527-1	277	6500	22178	23.5			28	2198
04926502	FSS-6548-3	480	6500	22178	13.5	7.8		28	2198
04926602	FSS-6557-3	600	6500	22178	11.3	6.5	28	2198	
04883102	FSS-9520-3	208	9500	32414	45.67	26.39	31	2867	
04883202	FSS-9524-3	240	9500	32414	39.6	22.89	31	2867	
04883302	FSS-9527-1	277	9500	32414	34.3		31	2867	
04883402	FSS-9548-3	480	9500	32414	19.8	11.44	31	2867	
04883502	FSS-9557-3	600	9500	32414	16.5	9.54	31	2867	

FSS/FSA REPLACEMENT ELEMENTS		
MFG CATALOG NUMBER	MFG MODEL NUMBER	LIST
01356002	64337-001	912
01356102	64337-002	912
01356202	64337-003	912
01356302	64337-004	912
01356402	64337-005	912
01356502	64337-006	912
01356602	64337-007	1062
01356702	64337-008	1062
01356802	64337-009	1062
01356902	64337-010	1062
01357002	64337-011	1062
01363402	64337-068	1331
01363502	64337-069	1331
01363602	64337-070	1331
01363702	64337-071	1331
01363802	64337-072	1331
01357102	64337-012	1403
01357202	64337-013	1403
01357302	64337-014	1403
01357402	64337-015	1403
01357502	64337-016	1403
01357602	64337-017	1302
01357702	64337-018	1302
01357802	64337-019	1302
01357902	64337-020	1302
01358002	64337-021	1302

Suspension Heating Application

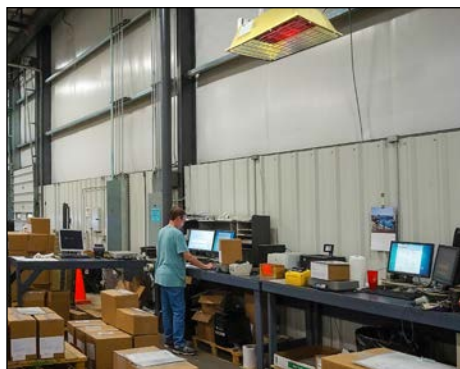

Spot Indoor Heaters

- Directional heating systems for where and when you need it
- No element glare
- No glass materials
- Rigid housing & element structure
- Designed for rugged & dirty environments
- Delivers higher and more uniform heat output with less energy consumption
- Ideal spot heating system for high-bay buildings up to 24'

FSS Series Heavy Duty Flat Panel Emitter Electric Overhead Infrared Heater

FSS-95

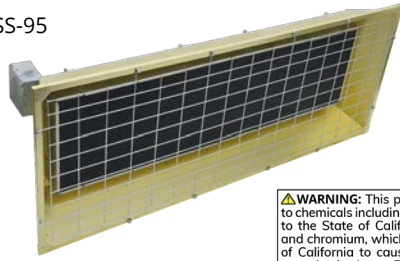

(2) FSS-95 heaters with TMK-95 Tandem Mountin Kit



WARNING: This product can expose you to chemicals including nickel which is known to the State of California to cause cancer, and chromium, which is known to the State of California to cause birth defects and/or reproductive harm. For more information go to www.P65Warnings.ca.gov.

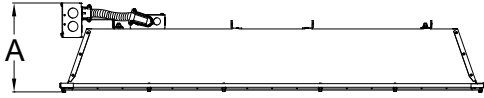

3/4" K.O. ON FSS-43,-95
1/2" K.O. ON FSS-14, -31

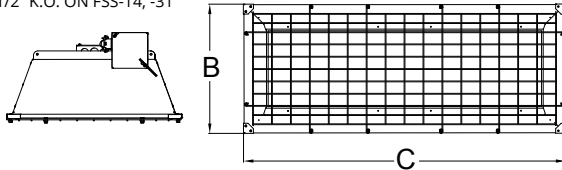

FSS Series Dimensions

MFG MODEL NUMBER	DIMENSIONS (in.)		
	"A" DEPTH	"B" WIDTH	"C" LENGTH
FSS-14	8 ½	9	26
FSS-31	8 ½	9	46
FSS-43	9 ¾	20	29
FSS-65	9 ¾	20	38
FSS-95	7 ¾	20	49
FSS-95 TANDEM	7 ¾	20	108

Mounting Clearances & Recommended Mounting Height

REQUIRED MINIMUM MOUNTING CLEARANCES	KW	RECOMMENDED MOUNTING HEIGHT
FSS-14 and FSS-31 - 6" from ceiling FSS-43, FSS-65 and FSS-95 - 24" from ceiling 36" from vertical surface & from another heater 72" from face of heater to combustible surface	1.4	8' - 10'
	3.1	8' - 12'
	4.3	10' - 14'
	6.5	10' - 15'
	9.5	12' - 16'
FSS-95 Tandem Only	(2) 9.5	15' - 30'

Sizing Chart

MOUNTING HEIGHT	MFG MODEL NUMBER	LENGTH	WIDTH	COVERAGE (SQ. FT.)	WATTS (SQ. FT.)
8'	FSS-14	8	8	64	22.7
	FSS-31	9	8	72	43.8
10'	FSS-14	11	10	110	13.2
	FSS-31	11	10	110	28.6
	FSS-43	12	10	120	35.8
12'	FSS-31	12	11.5	138	22.8
	FSS-43	14	12	168	25.6
	FSS-95	15	13	195	48.7
14'	FSS-43	16	14	224	19.2
	FSS-95	18	16	288	33.0
16'	FSS-43	18	16	288	14.9
	FSS-65	19	17	323	20.1
	FSS-95	21	18	378	25.1
	FSS-95 TANDEM	24	19	456	41.7
18'	FSS-65	22	19	418	15.5
	FSS-95	23	20	460	20.7
	FSS-95 TANDEM	28	20	560	33.9
20'	FSS-95 TANDEM	28	23	644	29.5
24'	FSS-95 TANDEM	33	27	891	21.3
30'	FSS-95 TANDEM	41	32	1312	14.5

Product Specifications

Housing & Construction:

.040 Gold anodized Aluminum housing for efficient, long-term reflectivity and corrosion resistance. High-density radiant heat. Housing is ETL Listed for indoor, dry environment applications only. Made in U.S.A.

Reflector:

60 degree symmetric heat pattern, reference the sizing chart to determine overall coverage based on the mounting height.

Elements:

Heavy duty flat panel emitter. Available wattages in 1450, 3150, 4300 and 9500 Watts per element. Available in standard voltages from 120 to 600 Volts.

Controls:

Flat panel emitter heaters are not manufactured with any control device on the unit. All controls and accessories should be specified as remote mounted. Please consult the technical sales department of factory for help in determining applicable controls. Please follow installation instructions that accompany each heater.

Accessories:

Power contactor panels.

ICP Control Panels



- NEMA 4 outdoor rated control box
- Door interlock disconnect switch
- Custom made to customers specifications
- SCR and proportional controls optional
- Circuit breakers sized for heater load per stage
- Please see ICP page to select panel to control one or multiple units, if required.

WARNING: This product can expose you to chemicals including nickel which is known to the State of California to cause cancer, and chromium, which is known to the State of California to cause birth defects and/or reproductive harm. For more information go to www.P65Warnings.ca.gov.

FSA Series Architectural Flat Panel Emitter Electric Overhead Infrared Heater

Architectural Overhead Infrared Heaters for *Indoor* Spot Heating, Zone, or Total Area Heating Applications



FSA-14



FSA-95



FSA-65



FSA-43



FSA-31

⚠ WARNING: This product can expose you to chemicals including nickel which is known to the State of California to cause cancer, and chromium, which is known to the State of California to cause birth defects and/or reproductive harm. For more information go to www.P65Warnings.ca.gov.



- ETL C/US Listed for suspended high-bay indoor or protected outdoor applications
- Designed for spot / zone or total area heating applications
- Heating elements included (Heavy Duty Single Flat Panel Emitter)
- Medium wave emitter operates at 78.5% radiant efficiency - with a 25,000 hour life expectancy
- Extruded aluminum housing with a nickel-gray finish, providing a 60° symmetrical heat pattern
- Electrical enclosure included for direct wire installation
- Single or three-phase wiring configurations
- "L" brackets included on the top of the heating housing for chain suspension, wall mounting, or ceiling mounting options
- Units can be surface mounted, semi-recessed, or fully-recessed
- Zinc plated heavy-gauge safety grills included for all models
- Optional wall mounting bracket sold separately
- Shipped fully assembled and made in U.S.A.

Standard Models

MFG CATALOG NUMBER	MFG MODEL NUMBER	WATTS	VOLTS	PHASE	BTUs / Hr.	AMPS		WT. (LBS)	LIST
						1-PH	3-PH		
04889002	FSA-1412-1	1450	120	1	4947	12.1		13	1557
04889102	FSA-1420-1	1450	208	1	4947	6.97		13	1557
04889202	FSA-1424-1	1450	240	1	4947	6.04		13	1557
04889302	FSA-1427-1	1450	277	1	4947	5.25		13	1557
04889402	FSA-1448-1	1450	480	1	4947	3.02		13	1557
04889502	FSA-1457-1	1450	600	1	4947	2.52		13	1557
04889602	FSA-3120-1	3150	208	1	10784	15.14		22	1774
04889702	FSA-3124-1	3150	240	1	10784	13.13		22	1774
04889802	FSA-3127-1	3150	277	1	10784	11.37		22	1774
04889902	FSA-3148-1	3150	480	1	10784	6.56		22	1774
04890002	FSA-3157-1	3150	600	1	10784	5.48		22	1774
04890102	FSA-4320-3	4300	208	1/3	14672	20.67	11.94	24	2358
04890202	FSA-4324-3	4300	240	1/3	14672	17.91	10.36	24	2358
04890302	FSA-4327-1	4300	277	1	14672	15.52		24	2358
04890402	FSA-4348-3	4300	480	1/3	14672	8.96	5.18	24	2358
04890502	FSA-4357-3	4300	600	1/3	14672	7.48	4.32	24	2358
04926702	FSA-6520-3	6500	208	1/3	22178	31.3	17.1	31	2890
04926802	FSA-6524-3	6500	240	1/3	22178	27.1	15.7	31	2890
04926902	FSA-6527-1	6500	277	1	22178	23.5		31	2890
04927002	FSA-6548-3	6500	480	1/3	22178	13.5	7.8	31	2890
04927102	FSA-6557-3	6500	600	1/3	22178	11.3	6.5	31	2890
04890602	FSA-9520-3	9500	208	1/3	32414	45.67	26.39	39	3480
04890702	FSA-9524-3	9500	240	1/3	32414	39.6	22.89	39	3480
04890802	FSA-9527-1	9500	277	1	32414	34.3		39	3480
04890902	FSA-9548-3	9500	480	1/3	32414	19.8	11.44	39	3480
04891002	FSA-9557-3	9500	600	1/3	32414	16.5	9.54	39	3480

FSS/FSA REPLACEMENT ELEMENTS		
MFG CATALOG NUMBER	MFG MODEL NUMBER	LIST
01356002	64337-001	912
01356102	64337-002	912
01356202	64337-003	912
01356302	64337-004	912
01356402	64337-005	912
01356502	64337-006	912
01356602	64337-007	1062
01356702	64337-008	1062
01356802	64337-009	1062
01356902	64337-010	1062
01357002	64337-011	1062
01357102	64337-012	1331
01357202	64337-013	1331
01357302	64337-014	1331
01357402	64337-015	1331
01357502	64337-016	1331
01357602	64337-017	1403
01357702	64337-018	1403
01357802	64337-019	1403
01357902	64337-020	1403
01358002	64337-021	1403
01363402	64337-068	1302
01363502	64337-069	1302
01363602	64337-070	1302
01363702	64337-071	1302
01363802	64337-072	1302



OPTIONAL WALL MOUNTING BRACKETS		
MFG CATALOG NUMBER	MFG MODEL NUMBER	LIST
04892002	FSA-14-31WMB	36
04892102	FSA-43-95WMB	69

FSA Series Dimensions

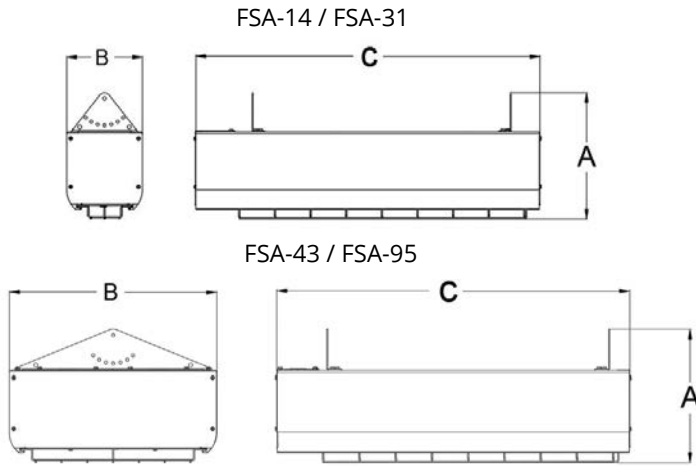

MFG MODEL NUMBER	DIMENSIONS (in.)		
	"A" DEPTH	"B" WIDTH	"C" LENGTH
FSA-14	9	5 3/4	26 1/16
FSA-31	9	5 3/4	47 1/16
FSA-43	9 1/4	14 3/4	25 1/16
FSA-65	9 1/4	14 3/4	34 1/16
FSA-95	9 1/4	14 3/4	47 1/16

Mounting Clearances & Recommended Mounting Height

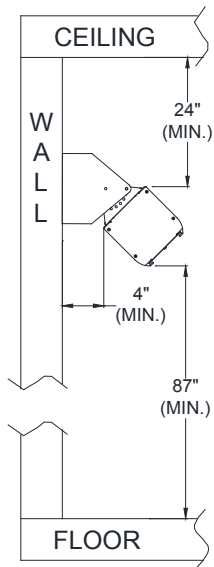

MOUNTING CLEARANCES		KW	RECOMMENDED MOUNTING HEIGHT
All FSA Models	24" from ceiling	1.4	8' - 10'
	36" from vertical surface & from another heater (4" when using optional mounting bracket)	3.1	8' - 12'
		4.3	10' - 14'
		6.5	10' - 15'
	72" from face of heater to combustible surface	9.5	12' - 16'

Product Specifications

Housing & Construction:

Extruded 6063 aluminum housing with protective grill. Powder coat silver finish for excellent durability and attractive appearance in commercial applications. ETL C/US listed for indoor, dry environments. Made in USA.

Elements:

Heavy duty flat panel emitter. Available wattages in 1450, 3150, 4300 and 9500 Watts per element. Available in standard voltages from 120 to 600 Volts.

*** Note: Replacement elements located on FSS Series pages.**

Controls:

Flat panel emitter heaters are not manufactured with any control device on the unit. All controls and accessories should be specified as remote mounted. Please consult the technical sales department of factory for help in determining applicable controls. Please follow installation instructions that accompany each heater.

Accessories:

Optional power controls pages 89-92.

Sizing Chart

MOUNTING HEIGHT	MFG MODEL NUMBER	LENGTH	WIDTH	COVERAGE (SQ. FT.)	WATTS (SQ. FT.)
8'	FSA-14	8	8	64	22.7
	FSA-31	9	8	72	43.8
10'	FSA-14	11	10	110	13.2
	FSA-31	11	10	110	28.6
	FSA-43	12	10	120	35.8
	FSA-65	13	10	130	50
12'	FSA-31	12	11.5	138	22.8
	FSA-43	14	12	168	25.6
	FSA-65	14	12.5	175	37.1
	FSA-95	15	13	195	48.7
14'	FSA-43	16	14	224	19.2
	FSA-95	18	16	288	33.0
16'	FSA-43	18	16	288	14.9
	FSA-95	21	18	378	25.1

Optional - ICP Control Panels



Features

- NEMA 4 outdoor rated control box
- Door interlock disconnect switch
- Custom made to customers specifications
- SCR and proportional controls optional
- Circuit breakers sized for heater load per stage
- See ICP page to select panel to control one or multiple units, if required

WARNING: This product can expose you to chemicals including nickel which is known to the State of California to cause cancer, and chromium, which is known to the State of California to cause birth defects and/or reproductive harm. For more information go to www.P65Warnings.ca.gov.

OCH Series Outdoor / Indoor Rated Quartz Electric Infrared Heater

Features

Heats solid objects, not the air!



⚠ WARNING: This product can expose you to chemicals including nickel which is known to the State of California to cause cancer, and chromium, which is known to the State of California to cause birth defects and/or reproductive harm. For more information go to www.P65Warnings.ca.gov.

- Frosted Quartz Tube heating element (included)
- Listed for suspended, totally exposed (outdoor) and indoor spot heating applications
- Finish: High-temp brown powder coated finish or corrosion resistant stainless steel 24 gauge housing
- 60° Symmetric Heat Pattern
- Gold anodized Aluminum reflector and end caps
- Painted models are direct wire, unless specified and are supplied with 6" lead wires for field connection in the internal wiring compartment. These models are available with a factory installed 6' cord set. The 208V model must have a field supplied plug.
- Stainless steel models include an electrical enclosure assembled to the end of the heater housing and (2) 6" long lead wires for direct field connection.
- Two 2' ft. long mounting chains and four S-Hooks included
- The OCH-Series can be surfaced mounted using the supplied mounting brackets which allow up to a 45° horizontal tilt adjustment.
- Made in U.S.A.

Standard Models

FINISH - BROWN			FINISH - STAINLESS Steel			CONNECTION TYPE	WATTS	BTUs	VOLTS	AMPS	Qtz. Tube Repl. Element	WT. (LBS)
MFG CATALOG NUMBER	MFG MODEL NUMBER	LIST	MFG CATALOG NUMBER	MFG MODEL NUMBER	LIST							
INCLUDES ELECTRICAL ENCLOSURE												
04804402	OCH-46-120VE	519	04805202	OCH-46-120V-SSE	607	Hardwired	1500	5120	120	12.5	671-3784	10
04804502	OCH-46-208VE	519	04805302	OCH-46-208V-SSE	607	Hardwired	2000	6826	208	9.6	671-5061	10
04804602	OCH-46-240VE	519	04805402	OCH-46-240V-SSE	607	Hardwired	2000	6826	240	8.3	671-3785	10
04804702	OCH-46-277VE	519	04805502	OCH-46-277V-SSE	607	Hardwired	2000	6826	277	7.2	671-5018	10
04804902	OCH-57-208VE	590	04805702	OCH-57-208V-SSE	672	Hardwired	3000	10239	208	14.4	671-5060	12
04804802	OCH-57-240VE	590	04805602	OCH-57-240V-SSE	672	Hardwired	3000	10239	240	12.5	671-3786	12
04805002	OCH-57-277VE	590	04805802	OCH-57-277V-SSE	672	Hardwired	3000	10239	277	10.8	671-5059	12
04805102	OCH-57-480VE	590	04805902	OCH-57-480V-SSE	672	Hardwired	2250	7679	480	4.7	671-5058	12
04859702	OCH-46-120VCE	558	---	---	---	Corded	1500	5120	120	12.5	671-3784	11
04859802	OCH-57-208VCE	657	---	---	---	Corded	3000	10239	208	14.4	671-5060	13
04859902	OCH-57-240VCE	657	---	---	---	Corded	3000	10239	240	12.5	671-3786	13

Recommended Accessories

MFG CATALOG NUMBER	MFG MODEL NUMBER	DESCRIPTION	FOR USE WITH	WT. (LBS)	LIST
04808802	OCHWG-46	Stainless Steel Wire Guards	OCH-46 Series Models	2	95
04808902	OCHWG-57	Stainless Steel Wire Guards	OCH-57 Series Models	2	100
08811239	VMB-41-SS	Wall Mtg. Brackets (2)	ALL OCH Models	12	350
04459402	VHC-15	Variable Heat Controller	120/208/240V OCH Models Only	3	267
04853502	VHC-32	Variable Heat Controller	208/240V OCH Models Only	3	985

OCH / OCH2 Sizing Chart

MOUNTING HEIGHT	HEATER MFG MODEL	WATTS	HEAT PATTERN COVERAGE (AT FLOOR LEVEL)			TOTAL WATTS / SQ. FT.
			LENGTH	WIDTH	SQ. FT.	
7'	OCH-46	1500	11	9	99	15.2
		2000	11	9	99	20.2
8'	OCH-46	1500	12	10	120	12.5
		2000	12	10	120	16.7
	OCH-57	3000	13	10	130	23.1
		2250	13	10	130	17.3
	OCH2-55	4000	16	10	160	25.0
		OCH2-66	6000	17	10	170
9'	OCH-46	1500	13	11	143	10.5
		2000	13	11	143	14.0
	OCH-57	3000	14	11	154	19.5
		2250	14	11	154	14.6
	OCH2-55	4000	15	12	180	16.7
		OCH2-66	6000	15	12	180
10'	OCH-57	3000	19	13	247	16.2
		2250	19	13	247	23.0
	OCH2-55	4000	20	13	260	12.6
		OCH2-66	6000	20	13	260
	OCH-57	3000	17	14	238	12.1
		2250	17	14	238	17.4
12'	OCH2-55	4000	22	15	330	9.4
		OCH2-66	6000	23	15	345
	OCH2-55	4000	25	17	425	
		OCH2-66	6000	26	17	442

Product Specifications

Series:

OCH-46

OCH-57

Dimensions:

Length: 48"; Width: 5.375"; Height: 6.5"

Length: 59"; Width: 5.375"; Height: 6.5"

Housing:

24 gauge Aluminized Steel with a baked on brown powder coat finish. Housing is cETLus Listed for indoor or outdoor applications. Horizontal mounting only.

Reflectors and End Caps:

.040 Gold anodized Aluminum reflectors and end caps for superior reflectiveness. 60 degree medium (symmetric) pattern only.

Elements:

Quartz Tubes. Frosted quartz envelope with a Nickel-Chromium coiled filament, porcelain end caps, and threaded-screw (stud) terminations. Fast heat-up and cool-down performance. Available Wattages from 1500 to 3000 Watts per element. Available voltages from 120 to 480 Volts.

Controls:

OCH Series heaters are not manufactured with any control device on the unit. All controls are accessories and should be specified as such. Please consult the technical sales department of factory for help in determining applicable controls. Please follow installation instructions that accompany each heater.

Accessories:

Adjustable mounting brackets (stainless steel only), vertical mounting brackets (stainless steel only), wire guards, thermostats, SCR controllers, and power contactor panels.

Mounting Configurations & Reflector Pattern

Mounting

- Chain, surface mount or use our vertical mounting bracket as shown below. Note: All units must be mounted horizontally.
- In-Built surface mounting bracket allows for fixture adjustment up to a 45° horizontal tilt.
- As shown, the heater may be suspended at any horizontal angle desired.

**Chain Mount:
(Chain supplied)**

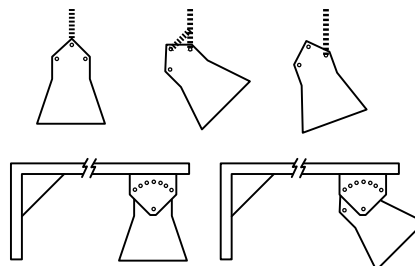
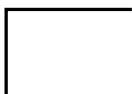

Reflector Pattern:

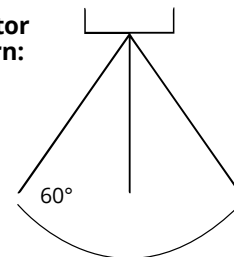

**Optional Vertical Mounting Bracket:
Model # VMB-41-SS**

Mounting Clearances & Recommended Mounting Height

MOUNTING CLEARANCES	RECOMMENDED MOUNTING HEIGHT	
3" from ceiling; 12" from vertical surface 72" from face of heater to combustible surface 36" from another heater	OCH-46	7'-9'
	OCH-57	8'-10'

OCH2 Series Outdoor / Indoor Rated Quartz Electric Infrared Heater



Features

- 2 Frosted Quartz Tube heating elements (included)
- Listed for suspended, totally exposed (outdoor) and indoor** spot heating applications
- Finish: High-temp brown powder coated finish or corrosion resistant stainless steel 20 gauge housing
- 60° symmetric heat pattern
- Gold anodized Aluminum reflector and end caps
- 6" long lead wires for direct field connection
- Two 2' ft. long mounting chains and four S-Hooks included
- The OCH2 Series can be wall or ceiling mounted using the supplied mounting brackets which allow up to a 45° horizontal tilt adjustment
- Made in U.S.A.

Series:	Dimensions:
OCH2-55	Length: 55"; Width: 7.5"; Height: 7"
OCH2-66	Length: 66"; Width: 7.5"; Height: 7"

Product Models

MFG CATALOG NUMBER	PAINTED BROWN	LIST	MFG CATALOG NUMBER	STAINLESS STEEL	LIST	WATTS	BTUs	VOLTS	AMPS	Qtz. Tube Repl. Element
	MFG MODEL NUMBER			MFG MODEL NUMBER						
04915502	OCH2-55-208V	670	04915902	OCH2-55-208V-SS	823	4000	13652	208	19.23	671-5062
04915602	OCH2-55-240V	670	04916002	OCH2-55-240V-SS	823	4000	13652	240	16.67	671-5063
04915702	OCH2-55-277V	670	04916102	OCH2-55-277V-SS	823	4000	13652	277	14.44	671-5064
04915802	*OCH2-55-480V	670	04916202	*OCH2-55-480V-SS	823	4000	13652	480	8.33	*671-5063
04916302	OCH2-66-208V	744	04916702	OCH2-66-208V-SS	863	6000	20478	208	28.85	671-5065
04916402	OCH2-66-240V	744	04916802	OCH2-66-240V-SS	863	6000	20478	240	25	671-5066
04916502	OCH2-66-277V	744	04916902	OCH2-66-277V-SS	863	6000	20478	277	21.66	671-5067
04916602	*OCH2-66-480V	744	04917002	*OCH2-66-480V-SS	863	6000	20478	480	12.5	*671-5066

*480V models use (2) 240V elements wired in series.

**Not for residential use

Product Accessories

MFG CATALOG NUMBER	MFG MODEL NUMBER	DESCRIPTION	FOR USE WITH	LIST
04917102	OCH2WG-55	Wire Guards	OCH2-55 Series Models	109
04917202	OCH2WG-66		OCH2-66 Series Models	131

Mounting Configurations & Reflector Pattern

Mounting

- Chain, surface mount or use our vertical mounting bracket as shown below.
- In-Built surface mounting bracket allows for fixture adjustment up to a 45° horizontal tilt.
- As shown, the heater may be suspended at any horizontal angle desired.

Note: All units must be mounted horizontally.

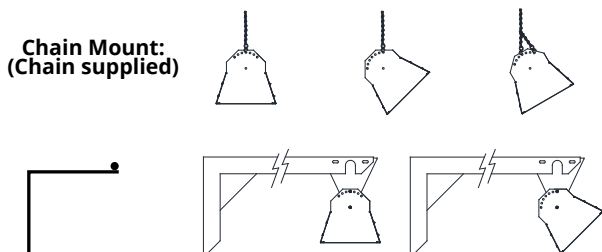

Reflector Pattern:

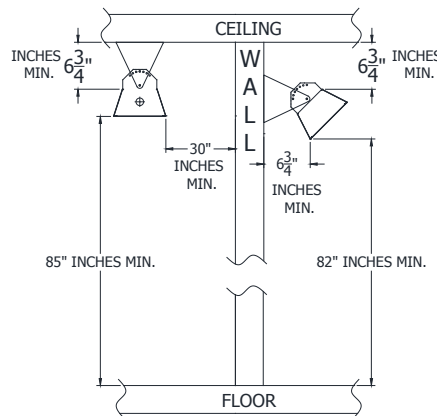
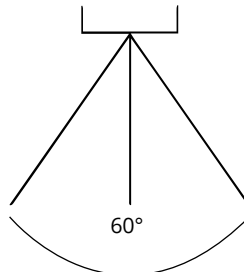

Optional Vertical Mounting Bracket:
Model # VMB-41-SS

Mounting Clearances & Recommended Mounting Height

MOUNTING CLEARANCES	RECOMMENDED MOUNTING HEIGHT	
6-3/4" from ceiling; 30" from vertical surface 85" from face of heater to combustable surface 36" from another heater	OCH2-55	9'-11'
	OCH2-66	10'-12'

RPH Series Outdoor Rated Stainless Steel Electric Infrared Heater



Mounting plate (provided) on top center allows heater to be mounted parallel or angled using a standard pipe nipple and box cover (supplied by installer)



- Instant, high-intensity radiant heat, with 30° symmetric heat pattern
- Listed for indoor spot heating and for outdoor unprotected applications
- Specialized Ruby "Red" Quartz Lamp infrared heating element for glare reduction
- Stainless steel housing with Coilzak Aluminum reflector for good reflectivity & corrosion resistance
- Heating element and mounting plate included
- Dimensions: 24" x 5 3/8" x 4 1/2."
- Made in U.S.A.

MOUNTING CLEARANCES		RECOMMENDED MOUNTING HEIGHT	
6" from ceiling 24" from vertical surface 72" from face of heater to combustible surface		RPH-120	8-10'
		RPH-208	
		RPH-240	

WARNING: This product can expose you to chemicals including nickel which is known to the State of California to cause cancer, and chromium, which is known to the State of California to cause birth defects and/or reproductive harm. For more information go to www.P65Warnings.ca.gov.

MFG CATALOG NUMBER	MFG MODEL NUMBER	WATTS	BTUs	VOLTS	PH	AMPS	REPLACEMENT QUARTZ LAMP	WT. (LBS)	LIST	OPTIONAL WIREGUARD		
										MFG CATALOG NUMBER	MFG MODEL NUMBER	LIST
04925202	RPH-120-A	1500	5120	120	1	12.5	632-1512	6	563	04466302	RPHWG	58
08845039	RPH-208-A	1600	5,461	208	1	7.7	632-1620	5				
08845139	RPH-240-A	1600	5,461	240	1	6.7	632-1624	5				

MM Series "Mitey Midget" Electric Infrared Heater



WARNING: This product can expose you to chemicals including nickel which is known to the State of California to cause cancer, and chromium, which is known to the State of California to cause birth defects and/or reproductive harm. For more information go to www.P65Warnings.ca.gov.

- Instant, high-intensity radiant heat, with 60° symmetric heat pattern
- MM heaters excel as people-heaters in areas requiring a linear, compact & concentrated heat source
- Listed for indoor industrial and commercial comfort heat applications
- Heavy duty Aluminum extrusion with a bright Aluminum insert for maximum reflectivity
- Anodized Aluminum housing, (0.62" thick)
- Heat Element **sold separately**
- Dimensions: 3.750" Wide x 3.380" High
- Made in U.S.A.

MOUNTING CLEARANCES
24" from ceiling & from vertical surface 24" from face of heater to combustible surface 36" from another heater

MFG CATALOG NUMBER	MFG MODEL NUMBER	MAX WATTS	MAX BTUs	MAX VOLTS	PH	UNIT LENGTH	WT. (LBS)	LIST	OPTIONAL WIREGUARDS		
									MFG CATALOG NUMBER	MFG MODEL NUMBER	LIST
04440102	MM-13A	500	1707	120	1	13"	3	387	04418902	MMWG-24	44
04427602	MM-18A	1000	3413	240	1	18"	4	396	04420402	MMWG-46	59
04495402	MM-24A	900 / 1600	5461	277	1	24"	5	417	04439002	MMWG-13	79
04427202	MM-33A	2500	8533	575	1	33"	6	450	04439102	MMWG-18	86
04420302	MM-46A	3000 / 3800	12457	575	1	46"	7	493	04439202	MMWG-33	101

Note: All MM-13A through MM-46A models are ETL Listed for use with Quartz Lamps Only! Lamp voltage must match supply voltage.

FFH Series Electric Utility Infrared Heater



- Both FFH Series Heaters are excellent for farrowing & finishing applications
- Both units feature an 8 ft. 18/3 grounded cordset to plug into any 120V service
- Gold anodized Aluminum reflectors, with a 90° symmetrical reflector pattern
- Compact housing design, with the following housing finish:
 - FFH-512A: Gold Anodized Finish
 - FFH-912B: Brown Enamel Finish
- Quartz Tubes Heat Element(s), Wire Guard & (2) 4' ft. Jack Chains are included
- FFH-912B only: Offers (2) on/off toggle switches to operate heating elements independently
- Listed for indoor industrial and commercial comfort heat
- Made in U.S.A.

SIZING CHART - FFH SERIES					
MOUNTING HEIGHT	HEATER MODEL	LENGTH	WIDTH	COVERAGE (Sq. Ft.)	WATTS / Sq. Ft.
6'	FFH-512A	7	6	42	13.1
	FFH-912B	6	7	42	21.4
7'	FFH-512A	8	7	56	9.8
	FFH-912B	7	8	56	16.1
8'	FFH-512A	9	8	72	7.6
	FFH-912B	8	9	72	12.5

MOUNTING CLEARANCES
3" from ceiling 24" from vertical surface 72" from floor

WARNING: This product can expose you to chemicals including nickel which is known to the State of California to cause cancer, and chromium, which is known to the State of California to cause birth defects and/or reproductive harm. For more information go to www.P65Warnings.ca.gov.

MFG CATALOG NUMBER	MFG MODEL NUMBER	WATTS	BTUs	VOLTS	PHASE	AMPS	REPLACEMENT QUARTZ TUBE	WT. (LBS)	Dimensions (in.)			LIST
									Length	Width	Height	
08838900	FFH-512A	550	1877	120	1	5	671-3492	4	22	5	3	373
08827814	FFH-912B	450/900	3072	120	1	8	671-3454	4	17	6	4	678

Electric Infrared Heating Elements

Clear & Red Quartz Lamps - 12mm Diameter

- Short wavelength infrared, color temp. emitted approx. 4100° F (high brightness)
- Approximately 96% radiant efficiency
- Excellent resistance to thermal shock
- Highest moisture resistance and quickest heat up time
- 3/8" Diameter clear or red quartz envelope
- Coiled tungsten filament; seal

Model prefix types:

630 = Horizontal Burning "Clear"
 631 = Vertical OR
 Horizontal Burning "Clear"
 632 = Horizontal Burning "Red"

Notes:

- Life expectancy of all heating elements = 5,000 hrs
- All heating elements operate at 50 / 60 Hertz.

WARNING: This product can expose you to chemicals including nickel which is known to the State of California to cause cancer, and chromium, which is known to the State of California to cause birth defects and/or reproductive harm. For more information go to www.P65Warnings.ca.gov.

MFG CATALOG NUMBER	MFG MODEL NUMBER	WATTS	VOLTS	LENGTH (IN.)		ENVELOPE TYPE	FITS MODEL	LIST
				Overall	Heated			
04400502	630-05129	500	120	8 1/16	5	12mm CLEAR	MM-13A	175
04401602	630-16209	1600	208	19 1/16	16	12mm CLEAR	222, 223, or MM-24A	206
04401702	630-16249	1600	240	19 1/16	16	12mm CLEAR	222, 223, or MM-24A	206
04409902	631-16249	1600	240	19 1/16	16	12mm CLEAR	222, 223, or MM-24A	249
04401802	630-16279	1600	277	19 1/16	16	12mm CLEAR	222, 223, or MM-24A	200
04817302	630-16489	1600	480	19 1/16	16	12mm CLEAR	222, 223, or MM-24A	249
04817402	630-25209	2500	208	28 1/16	25	12mm CLEAR	342, 343, or MM-33A	292
04817502	630-25249	2500	240	28 1/16	25	12mm CLEAR	342, 343, or MM-33A	292
04817602	630-25279	2500	277	28 1/16	25	12mm CLEAR	342, 343, or MM-33A	318
04405402	630-25489	2500	480	28 1/16	25	12mm CLEAR	342, 343, or MM-33A	259
04403602	631-25489	2500	480	28 1/16	25	12mm CLEAR	342, 343, or MM-33A	273
04406802	631-25609	2500	600	28 1/16	25	12mm CLEAR	342, 343, or MM-33A	281
04406702	630-36489	3650	480	41 1/16	38	12mm CLEAR	462, 463, or MM-46A	384
04462302	630-38579	3800	577	41 1/16	38	12mm CLEAR	462, 463, or MM-46A	384
04441302	631-38579	3800	577	41 1/16	38	12mm CLEAR	462, 463, or MM-46A	393
04914602	632-15129	1500	120	19 1/16	16	12mm CLEAR	RPH ONLY	243
04461502	632-16209	1600	208	19 1/16	16	12mm RED or RPH	222/223 or RPH	243
04461602	632-16249	1600	240	19 1/16	16	12mm RED or RPH	222/223 or RPH	243
04462202	632-25489	2500	480	28 1/16	25	12mm RED or RPH	342 or 343	284

Quartz Tubes

- Medium wavelength infrared, color temp emitting approx. 1800°F (bright orange glow)
- Approximately 60% radiant efficiency
- Nickel-Chromium alloy coiled element with porcelain end caps and pigtailed termination
- 5/8" Diameter frosted quartz envelope
- Moderate heat-up/cool-down

Notes:

- Life expectancy of all heating elements = 5,000 hours
- All heating elements operate at 50 / 60 Hertz.

WARNING: This product can expose you to chemicals including nickel which is known to the State of California to cause cancer, and chromium, which is known to the State of California to cause birth defects and/or reproductive harm. For more information go to www.P65Warnings.ca.gov.

MFG CATALOG NUMBER	MFG MODEL NUMBER	WATTS	VOLTS	LENGTH (IN.)		FITS MODEL	LIST
				Overall	Heated		
04432302	671-3784	1500	120	39 1/16	34 3/16	OCH-46	208
04418102	671-5061	2000	208	39 1/16	34 3/16	OCH-46	208
04418002	671-3785	2000	240	39 1/16	34 3/16	OCH-46	208
04419302	671-5018	2000	277	39 1/16	34 3/16	OCH-46	208
04416602	671-5060	3000	208	50 1/16	45 3/16	OCH-57	231
04414702	671-3786	3000	240	50 1/16	45 3/16	OCH-57	231
04419402	671-5059	3000	277	50 1/16	45 3/16	OCH-57	231
04419502	671-5058	2250	480	50 1/16	45 3/16	OCH-57	231
04914702	671-5062	2000	208	48 3/8	43	OCH2-55	225
04914802	671-5063	2000	240	48 3/8	43	OCH2-55	225
04914902	671-5064	2000	277	48 3/8	43	OCH2-55	225
04915002	671-5065	3000	208	59 1/4	53 3/8	OCH2-66	238
04915102	671-5066	3000	240	59 1/4	53 3/8	OCH2-66	238
04915202	671-5067	3000	277	59 1/4	53 3/8	OCH2-66	238
04403502	671-3454	450	120	12 1/16	8 3/16	FFH-912B	132
04400802	671-3492*	550	120	19 1/2	16	FFH-512A	142
04462402	671-5056	1000	120	18 3/16	14 1/16	CH-2212-1C	154
04462502	671-5057	1425	240	27 3/16	23 3/16	CH-6424-1C	175

*3/8" Diameter

Flat Panel Emitter Medium Wave Replacement Complete Conversion Kits - MR, CH, & FHK

- Medium wavelength infrared
- Color temp emitting approx. 1650°F
- Dull orange glow
- 78.5% radiant efficiency
- Black quartz composite face
- Non-glare & no glass materials
- Wound resistance wire consists of iron, chromium, & aluminum alloy
- Refractory blanket insulation
- High temp ceramic fiberboard
- Aluminized steel enclosure frame
- Electrical junction box
- Slow heat-up/cool-down
- 25,000 life expectancy
- Operates on 50 / 60 Hertz

Notes:

- Life expectancy of all heating elements = 25,000 hours
- All heating elements operate at 50 / 60 Hertz

WARNING: This product can expose you to chemicals including nickel which is known to the State of California to cause cancer, and chromium, which is known to the State of California to cause birth defects and/or reproductive harm. For more information go to www.P65Warnings.ca.gov.

CH & MR SERIES - FLAT PANEL EMITTER CONVERSION KITS						
MFG CATALOG NUMBER	MFG MODEL NUMBER	WATTS	VOLTS	LIST	FOR USE WITH OLD MODEL #:	
01358102	64337-022	3150	208	1331	MR-420-1, CH-420-1C, CH-420-3A	
01358202	64337-023		240		MR-424-1, CH-424-1C, CH-424-1A	
01358302	64337-024		277		MR-427-1, CH-427-1C, CH-427-1A	
01358402	64337-025		480		MR-448-1, CH-448-1C, CH-448-1A	
01358502	64337-026	4300	600	1642	MR-457-1, CH-457-1C, CH-457-1A	
01358602	64337-027		208		MR-620-3, CH-620-3C, CH-620-3A	
01358702	64337-028		240		MR-624-3, CH-624-3C, CH-624-3A	
01358802	64337-029		277		MR-627-3, CH-627-3C, CH-627-3A	
01358902	64337-030	9500	480	2420	MR-648-3, CH-648-3C, CH-648-3A	
01359002	64337-031		600		MR-657-3, CH-657-3C, CH-657-3A	
01359102	64337-032		208		MR-1320-3, CH-1320-3B, CH-1320-3A	
01359202	64337-033		240		MR-1324-3, CH-1324-3B, CH-1324-3A	
01359302	64337-034	9500	277	2460	MR-1327-3, CH-1327-3B, CH-1327-3A	
01359402	64337-035		480		MR-1348-3, CH-1348-3B, CH-1348-3A	
01359502	64337-036		600		MR-1357-3, CH-1357-3B, CH-1357-3A	
01359602	64337-037		208		MR-2720-3, CH-2720-3C, CH-2720-3B	
01359702	64337-038	9500	240	2460	MR-2724-3, CH-2724-3C, CH-2724-3B	
01359802	64337-039		277		MR-2727-3, CH-2727-3C, CH-2727-3B	
01359902	64337-040		480		MR-2748-3, CH-2748-3C, CH-2748-3B	
01360002	64337-041		600		MR-2757-3, CH-2757-3C, CH-2757-3B	
FHK Series - Flat Panel Emitter Conversion Kits						
MFG CATALOG NUMBER	MFG MODEL NUMBER	WATTS	VOLTS	LIST	FOR USE WITH OLD MODEL #:	
01360802	64337-049	4300	208	1688	FHK-620-3A	
01360902	64337-050		240		FHK-624-3A	
01361002	64337-051		480		FHK-648-3A	
01361102	64337-052	9500	208	2436	FHK-1320-3A	
01361202	64337-053		240		FHK-1324-3A	
01361302	64337-054		480		FHK-1348-3A	

Note: There are no element replacement kits for CH-2, MR-2, FHK-2, or FHK-4 model series heaters.

Note: There are no element replacement kits for CH-2, MR-2, FHK-2, or FHK-4 model series heaters.

Electric Infrared Heating Controls



VHC-66 & VHC-99

- VHC-66 & VHC-99 SCR variable voltage controller w/ potentiometer.
- Potentiometer can be mounted on enclosure or remotely in a 2x4 electrical wall box (not supplied)
- Can be used on all Fostoria infrared 208/240V single phase products; with heat load up to 48-amps
- Soft start operation to avoid high amperage inrush current on circuits
- NEMA 1 Aluminized or gray powder coated epoxy finish enclosure
- Customized color options are available

WARNING: This product can expose you to chemicals including nickel which is known to the State of California to cause cancer, and chromium, which is known to the State of California to cause birth defects and/or reproductive harm. For more information go to www.P65Warnings.ca.gov.



- Solid state variable device controls heat loads up to 15-Amps
- 120/208/240 Volt "In-Line" Controller
- Built in on/off knob switch with positive "off" & surface plate included
- Designed for a 2" x 4" electrical wall box mounting (not supplied)
- Must be mounted in a protected area.
- Can only operate Fostoria Quartz Tube Infrared Heaters



VHC-32

- Solid State phase angle variable "Triac" knob controller adjusts heat settings from 10-100% with heat loads up to 15.4-Amps
- 208/240 VAC single-phase, single stage controller, 3200 Watt max
- Positive "off" & built-in on/off
- Rocker switch lights "red" during operation.
- NEMA 1 Aluminum enclosure with stainless steel face plate designed for wall mounting or suitable for semi-recessed applications
- Must be mounted in a protected area.
- Can be used on all Fostoria IR 208/240V single phase products; with heat load up to 15.4 Amps"



18D-2-80CF ENC

30-Amp or 80-Amp Enc.

- SCR Voltage Controller - 80 Amp MAX.
- Includes (1) 24-volt Potentiometer (3" square) to control the heat output
- Only operates Quartz Lamps at 240 or 208-Volts, single phase only
- Potentiometer can be mounted outside, but the SCR must be located in a protected area
- Factory wired with millisecond fuses included

MFG CATALOG NUMBER	MFG MODEL NUMBER	DESCRIPTION	DIMENSION (IN.)			WT. (LBS)	LIST
			Height	Width	Depth		
04853502	VHC-32	Variable Heat Controller 208/240-Volt; 15.4 Amp	5	5	3	3	985
04459402	VHC-15	Variable Heat Controller 120/208/240-Volt; 15 Amp	5	5	3	3	267
04459502	FTC-30	30 min. spring wound timer; 208/240-Volt; 28 Amp	5	5	2	3	446
04456402	18D-2-30CF (Enclosed)	SCR Controller - 26 Amp MAX; Enclosure Included	12	10	8	15	1924
04456502	18D-2-80CF (Enclosed)	SCR Controller - 80 Amp MAX; Enclosure Included	14	12	8	29	2566
04924602	VHC-66	Variable Heat Controller 208/240-Volt; 32 Amp MAX	10	10	6	9	1949
04924702	VHC-66P	Variable Heat Controller (Gray) 208/240-Volt; 32 Amp MAX	10	10	6	9	2035
04924802	VHC-99	Variable Heat Controller 208/240-Volt; 48 Amp MAX	10	10	6	9	2156
04924902	VHC-99P	Variable Heat Controller (Gray) 208/240-Volt; 48 Amp MAX	10	10	6	9	2251

Snow & Ice Detectors



CIT-1



APS-3C

WARNING: This product can expose you to chemicals including nickel which is known to the State of California to cause cancer, and chromium, which is known to the State of California to cause birth defects and/or reproductive harm. For more information go to www.P65Warnings.ca.gov.

- Main control unit for Automatic Snow & Ice Control Systems
- By sensing both temperature and moisture the system activates and melts any snow & ice accumulations until conditions subside
- NEMA 3R Enclosure is UL Listed and houses timers and switching electronics to operate the system
- Capability to monitor up to 6 sensors (CIT-1)
- Unit can be manually activated and can be controlled and monitored from an optional remote switch (Model RCU- contact factory)
- Positioned above ground to maximize the sensors capability
- Detects falling or blowing of precipitation such as snow when the temperature is below 38°F
- Most common sensor device

MFG CATALOG NUMBER	MFG MODEL NUMBER	DESCRIPTION	DIMENSION (IN.)			WT. (LBS)	LIST
			Depth	Width	Height		
03196100	APS-3C	Snow / Ice Control Switch	6.56	11.5	9.25	8	4970
03197600	CIT-1	General Purpose Snow Sensor	3.25	3.25	4.13	1	1605

Note: Any snow & ice control system should be used with the correct sized control panel (with contactors & fusing) as supplied by factory or your electrical contractor. The APS-3C requires a control device (CIT-1) in order to operate properly and must use 120V. Additional controls available through manufacturer.

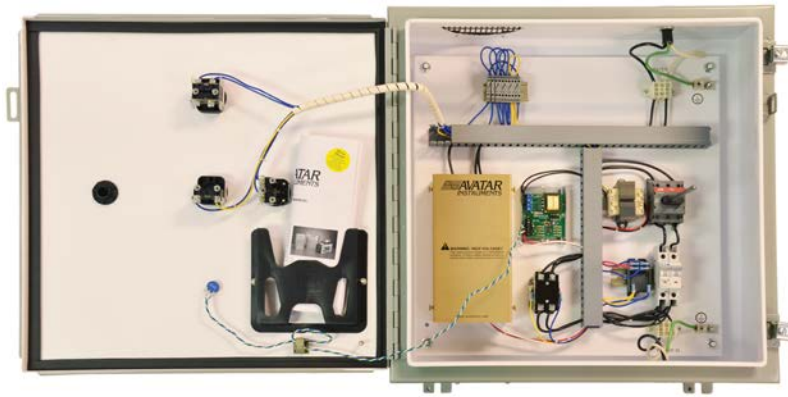

ICP panels are custom made and designed to be used with any TPI infrared heating product. Each panel requires an individually wired circuit for field connection to the panel from the heater. ICP panels are designed and constructed with all controls, factory wired, and ETL listed.

⚠ WARNING: This product can expose you to chemicals including nickel which is known to the State of California to cause cancer, and chromium, which is known to the State of California to cause birth defects and/or reproductive harm. For more information go to www.P65Warnings.ca.gov.

Standard Controls

- NEMA 4 outdoor rated industrial gray powder coated
- Door interlock disconnect switch
- Circuit breaker sized for heater load per stage
- Disconnecting magnetic contactor per stage
- Terminal block for field connection to heater per stage
- 24 Volt transformer (120 Volt transformer optional for snow/ice detectors)
- Control terminal block for connection to staging control



NUMBER OF STAGES	PANEL SIZE	LIST
1	24" x 24" x 8"	3921
2		4703
3		5488
4	30" x 30" x 8"	6273
5		7840
6		8624
7	36" x 36" x 8"	9406
8		11759
9		12543

Note: Panel size subject to change depending on options selected
Note: Products listed in this section are custom built and subject to 100% cancellation/restock charges

Snow/Ice Detection Information

- Snow and ice units activate the system and melts any snow and ice accumulations until conditions subside based on detection of temperature and moisture.
- 120 Volt control required for use with TPI supplied snow and ice melting options. This can be indicated by selecting 120 for control voltage option in the model number designator.
- Snow/Ice control switch: APS-3C (capability of monitoring 6 snow sensors) NEMA 3R Enclosure is UL Listed and houses timers and switching electronics to operate the system.

Additional Panel Information

- All heater stages are wired to control terminal block individually and can be controlled individually or grouped together for multiple heaters to be energized by one thermostat or field supplied controller as required.
- Infrared heating products can be economically controlled using SCR proportional controls. Proportional controls can be operated by potentiometer built into the control panel with a manual dial or field wired to building management system using 4-20 MA input to the control panel by control system.
- Timers to allow heater to operate for designed time can be mounted in the control panel to turn heater off in areas where occupancy is intermittent, such as smoking areas or public platforms.
- Panel sizes can vary with additional optional controls - consult factory.



Electric Infrared Heating Controls - ICP Control Panels

GENERAL: ICP panels are built with NEMA rated enclosure and sub panels for mounting electrical controls for use in staging and control of electric heating products. Panels are designed to comply with local and national codes for in the field connections of TPI Corporation heating products.

CONTROLS: Controls for electric heating products shall include, but not be limited to, the following standard controls for TPI Corporation electric heating products:

- Door interlock disconnect switch for single point field power connection
- Circuit breakers sized for AMP load of individual heater rating
- Definite purpose disconnecting contactor for each heater circuit
- Line terminal block for field connection to heater
- Ground lugs as required by NEC
- Control transformer for control circuit

OPTIONAL CONTROLS:

- Snow and ice melting controllers:
- TPI controller - 120V field connection to controller
- Field supplied controllers must specify required voltage
- SCR proportional controllers:
- Potentiometer for manual control of infrared heaters
- 4-20 MA signal field supplied for control of infrared heaters



OPTIONAL ACCESSORIES:

- Power on indicator pilot lights
- Staging energized pilot lights
- Pilot switches for manual control per heaters
- Timer for internal control of heater cycle

HOW TO DESIGNATE A MODEL:

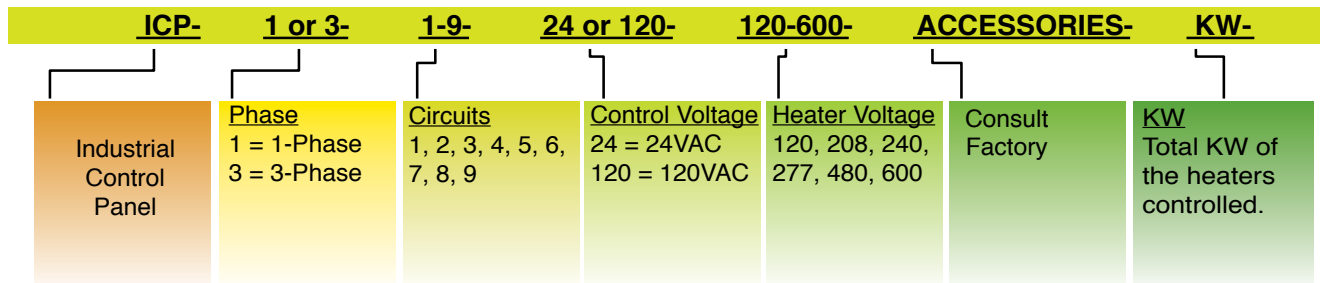

TPI Corporation manufactures the ICP panel for control of electric infrared heating products. The models listed below are standard infrared products and all volts, phase, and amps can be seen in the charts provided on the pages that correspond to the series.

INFRARED HEATER SERIES	HEATER DESCRIPTION
FSS / FSA	EMITTER TYPE BLACK BODY HEATER WITH GOLD ANODIZED REFLECTOR
TH / THA	QUARTZ LAMP PAINTED STEEL FIXTURE WITH GOLD ANODIZED REFLECTOR
THSS	QUARTZ LAMP STAINLESS STEEL FIXTURE WITH GOLD ANODIZED REFLECTOR
OCH / OCH2	OUTDOOR/INDOOR SINGLE LAMP QUARTZ TUBE ELEMENTS
RPH	OUTDOOR RATED STAINLESS STEEL SINGLE ELEMENT

Electric Infrared Heating Controls - FPC Control Panels



FEC-30-120

WARNING: This product can expose you to chemicals including nickel which is known to the State of California to cause cancer, and chromium, which is known to the State of California to cause birth defects and/or reproductive harm. For more information go to www.P65Warnings.ca.gov.

Contactor Enclosures

- NEMA 1 Enclosures
- Load rating up to 600V Max., 3-Pole
- Magnetic contactor
- Economical load handling / switch device, ideal for use with other control equipment

MFG CATALOG NUMBER	MFG MODEL NUMBER	CONTACTOR AMPS	COIL VOLTAGE	CABINET SIZE (IN.)			WT. (LBS)	LIST
				Depth	Width	Height		
04408502	FEC-30-120	30	120	5	6	10	5	324
04408602	FEC-30-240	30	208/240	5	6	10	5	324
04408702	FEC-60-120	60	120	5	6	10	5	499
04408802	FEC-60-240	60	208/240	5	6	10	5	499

Note: Installer to provide overload protection for all infrared heaters

Pre-Wired Contactor Panels

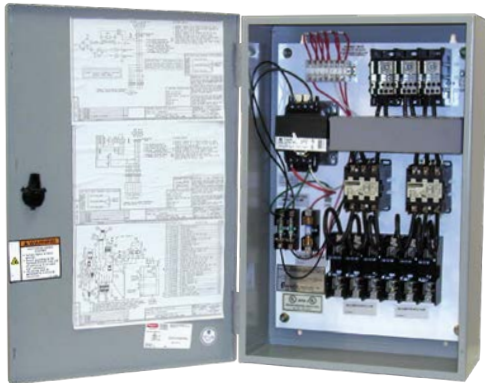

FPC2120

- **ONE HEATER PER CIRCUIT**
 - Max 48-Amps per circuit*
 - Step-down transformer for 24V or 120V control circuit
 - Secondary control circuit fusing
 - 3-phase load rated
 - NEMA 1 Enclosures
- The following controls are available:**
- Snow and Ice Detector (APS-3C) (120 volt control required)
 - Single and two-stage thermostats (Two-stage Thermostats require a minimum of 2 circuits)

IMPORTANT FUSING INFORMATION

Fuses are NOT included since panels can be used with various infrared heat sources.
 Quartz Lamp Heat Sources: Use FRS-600V (or equal) "Time Delay" fuses; Class RK-5.
 Quartz Tube & Flat Panel Emitter Heat Sources: Use KTS-R 600V (or equal) "Fast Acting" fuses; Class RK-1.

*Circuit fusing less than 35 Amps will require the use of fuse reducers - **Not included**

WARNING: This product can expose you to chemicals including nickel which is known to the State of California to cause cancer, and chromium, which is known to the State of California to cause birth defects and/or reproductive harm. For more information go to www.P65Warnings.ca.gov.



Standard Models

120-V CONTROL SYSTEM		24-V CONTROL SYSTEM		CIRCUITS	VOLTS	CABINET SIZE (IN.)			WT. (LBS)	LIST
MFG CATALOG NUMBER	MFG MODEL NUMBER	MFG CATALOG NUMBER	MFG MODEL NUMBER			DEPTH	WIDTH	HEIGHT		
04459902	FPC8110	04864302	FPC8210	1	208	6.75	16	24	52	3315
04460002	FPC2110	04864402	FPC2210	1	240	6.75	16	24	52	3315
04460102	FPC7110	04864502	FPC7210	1	277/480	6.75	16	24	52	3572
04460202	FPC4110	04864602	FPC4210	1	480	6.75	16	24	52	3231
04460302	FPC8120	04864702	FPC8220	2	208	6.75	16	24	70	4079
04460402	FPC2120	04864802	FPC2220	2	240	6.75	16	24	70	4079
04460502	FPC7120	04864902	FPC7220	2	277/480	6.75	16	24	70	4506
04460602	FPC4120	04865002	FPC4220	2	480	6.75	16	24	70	4080
04460702	FPC8140	04865102	FPC8240	4	208	6.75	24	30	88	6376
04460802	FPC2140	04865202	FPC2240	4	240	6.75	24	30	88	6376
04460902	FPC7140	04865302	FPC7240	4	277/480	6.75	24	30	88	6459
04461002	FPC4140	04865402	FPC4240	4	480	6.75	24	30	88	6376
04461102	FPC8160	04865502	FPC8260	6	208	6.75	30	36	106	6967
04461202	FPC2160	04865602	FPC2260	6	240	6.75	30	36	106	6967
04461302	FPC7160	04865702	FPC7260	6	277/480	6.75	30	36	106	7988
04461402	FPC4160	04865802	FPC4260	6	480	6.75	30	36	106	6967

FSP Series Heavy Duty Flat Panel Emitter Electric Portable Infrared Heater

Stand Models

Hand Cart Models

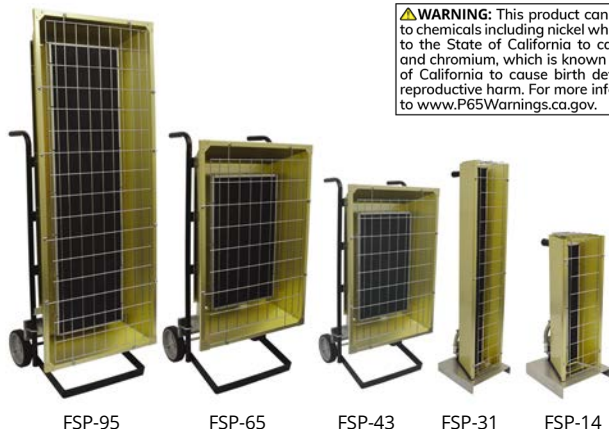

⚠️WARNING: This product can expose you to chemicals including nickel which is known to the State of California to cause cancer, and chromium, which is known to the State of California to cause birth defects and/or reproductive harm. For more information go to www.P65Warnings.ca.gov.

- High density medium wave radiant heat with 60° symmetrical heat pattern.
- 25,000 hour element life expectancy
- Approximately, 78.5% efficient versus 50% for metal sheath type elements.
- Rugged flat panel emitter can be used in high vibration areas
- Single or three phase available on select models
- Heavy duty wire guard mounted on long lasting gold anodized reflector
- Made in U.S.A.

Square Feet Heated

KW	NON-PROTECTED AREA		SEMI-PROTECTED AREA		Required Clearance (from front of heater)
	BELOW 35 °F	ABOVE 35 °F	BELOW 35 °F	ABOVE 35 °F	
1.45	25	36	40	50	3 feet
3.15	64	75	90	125	3 feet
4.3	85	100	120	150	4 feet
9.5	192	225	270	375	7 feet

Standard FSP Models

MFG CATALOG NUMBER	MFG MODEL NUMBER	WATTS	VOLTS	PHASE	BTUs / Hr.	AMPS		WT. (LBS)	LIST
						1 PH	3 PH		
04883702	FSP-1412-1C	1450	120	1	4947	12.1	N/A	17	1511
04883802	FSP-3120-1	3150	208	1	10749	15.4	N/A	23	1774
04883902	FSP-3124-1	3150	240	1	10749	13.13	N/A	23	1774
04884002	FSP-3127-1	3150	277	1	10749	11.37	N/A	23	1774
04884102	FSP-3148-1	3150	480	1	10749	6.56	N/A	23	1774
04884202	FSP-3157-1	3150	600	1	10749	6.48	N/A	23	1774
04884302	FSP-4320-3	4300	208	1 or 3	14972	20.67	11.94	32	2281
04884402	FSP-4324-3	4300	240	1 or 3	14972	17.91	10.36	32	2281
04884502	FSP-4327-1	4300	277	1	14972	15.52	N/A	32	2281
04884602	FSP-4348-3	4300	480	1 or 3	14972	8.96	5.18	32	2281
04884702	FSP-4357-3	4300	600	1 or 3	14972	7.48	4.32	32	2281
04927202	FSP-6520-3	6500	208	1 OR 3	22178	31.3	18.1	38	2590
04927302	FSP-6524-3	6500	240	1 OR 3	22178	27.1	15.7	38	2590
04927402	FSP-6527-1	6500	277	1	22178	23.5	N/A	38	2590
04927502	FSP-6548-3	6500	480	1 OR 3	22178	13.5	7.8	38	2590
04927602	FSP-6557-3	6500	600	1 OR 3	22178	11.3	6.5	38	2590
04884802	FSP-9520-3	9500	208	1 or 3	22178	45.67	26.39	38	3162
04884902	FSP-9524-3	9500	240	1 or 3	22178	39.68	22.89	38	3162
04885002	FSP-9527-1	9500	277	1	22178	34.3	N/A	38	3162
04885102	FSP-9548-3	9500	480	1 or 3	22178	19.79	11.44	38	3162
04885202	FSP-9557-3	9500	600	1 or 3	22178	16.52	9.54	38	3162

FSP Replacement Elements			Optional 25' Power Cord		
MFG CATALOG NUMBER	MFG MODEL NUMBER	LIST	MFG CATALOG NUMBER	MFG MODEL NUMBER	LIST
01360102	64337-042	912	N/A	N/A	N/A
01356602	64337-007	1062	08804600	SO 14/3	173
01360202	64337-043	1062	08804600	SO 14/3	173
01356802	64337-009	1062	08804600	SO 14/3	173
01360302	64337-044	1062	08804600	SO 14/3	173
01357002	64337-011	1062	08804600	SO 14/3	173
01361402	64337-055	1267	03164201	SO 12/4	238
01360402	64337-045	1331	08804900	SO 14/4	218
01361502	64337-056	1267	08804600	SO 14/3	173
01360502	64337-046	1331	08804900	SO 14/4	218
01357502	64337-016	1331	08804900	SO 14/4	450
01364402	64337-073	1302	03164201	SO 12/4	238
01364502	64337-074	1302	08804600	SO 14/3	173
01364602	64337-075	1302	08804900	SO 14/4	218
01364702	64337-076	1302	08805100	SO 8/4	450
01364802	64337-077	1302	08805200	SO 8/3	397
01361602	64337-057	1336	08805100	SO 8/4*	450
01360602	64337-047	1403	08805100	SO 8/4*	450
01361702	64337-058	1336	08805200	SO 8/3	397
01360702	64337-048	1403	03164201	SO 12/4	238
01362702	64337-063	1403	08804900	SO 14/4	218

*3 Phase only

Factory Pre-Wired FSP-14 Model With 15 Ft. Cord with Grounded Plug On/Off Switch

MFG CATALOG NUMBER	MFG MODEL NUMBER	TYPE	WATTS	VOLTS	PH	BTUs / Hr.	AMPS	WT. (LBS)	LIST
04883702	FSP-1412-1C	STAND	1450	120	1	4947	12.1	17	1511

FSP REPLACEMENT ELEMENTS		
MFG CATALOG NUMBER	MFG MODEL NUMBER	LIST
01360102	64337-042	912

Infrared Control Options

MFG CATALOG NUMBER	MFG MODEL NUMBER	DESCRIPTION	Operating Voltage (VAC)	Dimensions (In)			WT. (LBS)
				Ht.	Wd.	Dp.	
04858102	TO-SK-1	Tip-Over Switch	208V - 600V	10.3	10.3	5.0	12
05893702	DC-SK-1	Disconnect Switch	120V - 600V	5.0	6.0	4.0	5
04860202	GF-SK-1	Ground Fault Sensing Switch	208V - 600V	10.3	10.3	5.0	12

Model "TO" & "GF" features include a positive "off" & a built-in on/off rocker switch that glows red during operation. Additionally, enclosure can mount directly to the terminal box on the back of the heater (FSP-43/95 only) or be mounted to a remote wall surface.



TO-SK-1 or GF-SK-1

Note: All SK-1 Models have NEMA-1 Enclosure, 50-Amp Max. & 1/3-Phase Rated.

PCH Series Portable Quartz Infrared Spot Heater



Width: 53"
Height: 2-6'
Depth: 28"



WARNING: This product can expose you to chemicals including nickel which is known to the State of California to cause cancer, and chromium, which is known to the State of California to cause birth defects and/or reproductive harm. For more information go to www.P65Warnings.ca.gov.

Features

- Suitable for portable spot heat or for curing clear coat paint
- Height adjustable from 2' to 6'
- On-off rocker switch standard
- 4 casters included; Tip-Over power cutoff safety switch
- 60° symmetrical heat pattern
- 5/8" diameter quartz tube included
- Average element life is 5000 hours
- Bright Aluminum reflector and end caps
- 20-gauge powder coated steel housing
- 15' long, 3 wire (14/3) cordset with standard
- 3-prong NEMA 5-20P
- Made in U.S.A.

MFG CATALOG NUMBER	MFG MODEL NUMBER	WATTS	BTUs	VOLTS	PHASE	WT. (LBS)	LIST
08841110	PCH-48C	1500	5120	120	1	30	844
04914502	REPLACEMENT ELEMENT ASSEMBLY						231

Portable Infrared Instant On-Off Heat Gun



WARNING: This product can expose you to chemicals including nickel which is known to the State of California to cause cancer, and chromium, which is known to the State of California to cause birth defects and/or reproductive harm. For more information go to www.P65Warnings.ca.gov.

Features

- Provides instant spot heat in a controlled pattern
- Spot cure retouched paint and other finishes
- De-wrinkle or relax materials such as cloth-vinyl-leather
- T-3 Tungsten IR lamp
- Ergonomically friendly, easy-grip handle
- 20' long, 18/3 grd. cordset with GFCI plug
- Made in U.S.A.

MFG CATALOG NUMBER	MFG MODEL NUMBER	WATTS	VOLTS	AMPS	WT. (LBS)	LIST
05922802	RHG-1012A	1000	120	8.4	3	3030

Portable Electric Infrared Heat Panels

Features

- Portable panels are built to withstand rigors of industrial and heavy-commercial applications, such as auto collision repair shops
- 20 gauge steel frame, base, and housing construction
- 3" steel casters for high stability and ease of mobility
- Gold anodized Aluminum reflectors and end caps allow 10% faster cure time than polished Aluminum reflectors, especially in paint and dust-laden atmospheres
- Elements achieve full temperature in less than 2 minutes
- Fused disconnect switches are installed on the back of each unit
- Units are positioned with adjustable hinges allowing the user to use direct heat more precisely to the target area
- Gentle but effective medium-wave radiant heat can quickly boost, flash-off, or cure a variety of finishes, and lessens the chance of blistering and/or overheating the coating
- Medium-wave infrared heating elements are also effective for flash-off of water-based clear coatings being mandated by environmental agencies in many states
- Made in U.S.A.



General Curing Guidelines

Material Type	Solvent Based Primer	Water Based Primer	(2) Component Primer	Water Based Clear Coat	Acrylic enamel & Polyurethane Clear Coat	Urethane Clear Coat & High Solids Top Coat
Curing Time	3-5 mins	3-6 mins	8-20 mins	3-10 mins	12-30 mins	10-30 mins

Note: Curing times will vary depending on material and shop conditions. This chart is based on distances of 18-24" away from the target area.

Standard Models

MFG CATALOG NUMBER	MFG MODEL NUMBER	WATTS	VOLTS	AMPS	HEAT SOURCES	CABLE TYPE (20')	DIMENSION (IN.)		HEATED AREA (IN.)		WT. (LBS)	LIST
							Width	Height	Width	Height		
08841202	HP-5-QT	4,800	240	20	4	12-3 SO	44 5/8"	56 1/2"	40"	44"	116	4328
08841302	HP-6-QT	6,400		26.7	4	12-3 SO	66 5/8"		61"		141	5004
08841402	HP-11-QT	11,200		46.7	7	6-3 SO	66 5/8"	89 1/2"		77"	225	9209

The Electric Alternative to Propane & Kerosene Space Heaters

- Heater housing has a safety yellow textured powder coated finish and includes protective black finish guards on both air intake and output openings
- Long-life finned tubular heating elements, high-limit thermal cutout switch with automatic reset
- Control knob allows for fan only operation and thermostat adjustment from 40° to 100° F
- Fan-forced electric heaters generate 800 to as much as 2500-CFM's
- 9-30kW units features a built-in rotating stop allowing housing adjustments for up to 90° from center axis
- Includes access panel for direct wiring connections
- 10" industrial heavy duty wheels and handle for easy portability over all surface types
- 45-60kW units include two front locking casters and lifting handles for easy portability
- 9kW & 10kW units include a factory 10' long pre-wired cable and straight blade range plug; optional cord for all other models
- ETL Listed for USA & Canada

Application Solutions

- Provides temporary climate control for interior jobsite heating
- Drywall & building contractors – assist in drying applications
- Best indoor electric heating product over propane or fossil fuel units
- Safe operating unit – operate unit overnight to elevate temperature
- Can be operated unattended without anytime wasted for refueling
- Clean, quiet & safe electric fan-forced heater

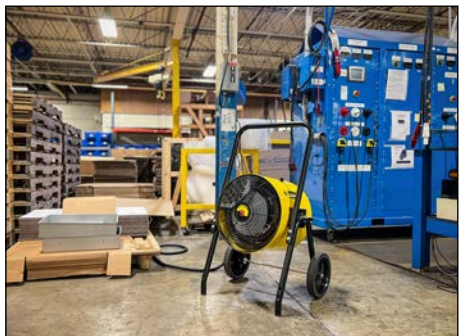

9/10kW

Note: FES09 uses 3-wire 40amp plug



Sizing FES Models

Sizing Chart Portable Electric Salamander Heaters					
KW SIZE	TEMP RISE	VOLTAGE	PHASE	MAX. SQ. FT.*	MAX. CEILING HEIGHT
9 kW	25°	240V	1	600 up to 900	12'
10 kW	30°	240V	1	750 up to 1000	15'
15 kW	45°	208, 240, 480V	1 or 3	1000 up to 1500	15'
30 kW	45°	480, 575V	1	1500 up to 2000	18'
45 kW	70°	480, 575V	3	2000 up to 2400	24'
60 kW	74°	480, 575V	3	2400 up to 3600	24'

*Based on using one single unit

What to know when selecting the correct FES Heater:

1. Determine your operating voltage and electrical phase for your job site.
2. Calculate the square footage of the area to heat (Length x Width)
3. Measure the maximum ceiling height for your area.
4. Know you must have insulation and at least 10-watts/sq.ft. to effectively heat your area. The higher your ceiling the higher watts/sq.ft. needed.
5. Temperature rise is calculated by taking the room temperature then adding the temp rise (see chart); room temp + temp rise = discharge temp

Standard FES Models

MFG CATALOG NUMBER	MFG MODEL NUMBER	KW	BTUs	VOLTS	PH	AMPS	TEMP RISE	CFM	SO TYPE*	WT. (LBS)	LIST
08744302	FES-0924-1C	9	30717	240	1	38	25°F	800	**	55	2507
08860010	FES-1024-1CA	10	34130	240	1	42	30°F	800	**	60	2507
08860110	FES-1520-3A	15	51195	208	3	42	45°F	800	6/4	65	2634
08860710	FES-1524-1A	15	51195	240	1	63	45°F	800	4/3	69	2634
08860210	FES-1524-3E	15	51195	240	3	36	45°F	800	6/4	65	2634
08860310	FES-1548-3E	15	51195	480	3	18	45°F	800	12/4	65	2634
08860410	FES-1560-3A	15	51195	600	3	15	45°F	800	12/4	65	2634
08860510	FES-3048-3A	30	102390	480	3	36	90°F	1100	6/4	83	4152
08860610	FES-3060-3A	30	102390	600	3	29	90°F	1100	6/4	65	4359
08722202	FES-4548-3	45	153585	480	3	55.4	70°F	2200	4/4	198	6864
04874002	FES-4557-3	45	153585	575	3	46.2	70°F	2200	4/4	198	7214
04915302	FES-6048-3	60	204780	480	3	73.5	74°F	2500	2/4	225	7590
04915402	FES-6057-3	60	204780	575	3	61.3	74°F	2500	4/4	225	8083

**9 & 10 KW, 240V, 1Phase factory pre-wired model with 10 ft. cable & straight blade range plug

OPTIONAL 25' POWER CORD*				
MFG CATALOG NUMBER	MFG MODEL NUMBER	FOR USE WITH FES MODEL	AMP RATING	LIST
03164001	SO 6/4	FES-1520-3A FES-1524-3E FES-3048-3A FES-3060-3A	45	495
08805300	SO 4/3	FES-1524-1A	70	428
03164201	SO 12/4	FES-1548-3E FES-1560-3A	20	238
03164301	SO 4/4	FES-4548-3 FES-4557-3 FES-6057-3	60	502
04917302	SO 2/4	FES-6048-3	80	561

Optional SO TYPE Power Cords



- All power cords are 25' long with SO oil resistant cable jacket
- Includes either 3 or 4 conductors
- Cable connectors included
- Plug NOT included
- Made in U.S.A.

⚠ WARNING: This product can expose you to chemicals including nickel which is known to the State of California to cause cancer, and chromium, which is known to the State of California to cause birth defects and/or reproductive harm. For more information go to www.P65Warnings.ca.gov.

YES Series Wall or Ceiling Models

- Same housing design & features used on all FES Series Heaters
- Includes steel mounting bracket with textured black powder coated finish allows for either wall or ceiling mount configurations
- Unit is ready for direct wiring
- Thermostat adjustment 40° to 100° F
- Made in U.S.A.



Ceiling Mounted

Wall Mounted

MFG CATALOG NUMBER	MFG MODEL NUMBER	KW	BTUs	VOLTS	PHASE	AMPS	TEMP RISE	WT. (LBS)	LIST
08860810	YES-1520-3A	15	51195	208	3	42	45°F	60	2507
08861810	YES-1524-1A	15	51195	240	1	63	45°F	60	2507
08860910	YES-1524-3E	15	51195	240	3	36	45°F	60	2507
08861010	YES-1548-3E	15	51195	480	3	18	45°F	60	2507
08861210	YES-3048-3A	30	102390	480	3	36	90°F	72	3953
08861310	YES-3060-3A	30	102390	600	3	29	90°F	72	4162



⚠ WARNING: This product can expose you to chemicals including nickel which is known to the State of California to cause cancer, and chromium, which is known to the State of California to cause birth defects and/or reproductive harm. For more information go to www.P65Warnings.ca.gov.

150TS Series 120 Volt Portable Electric Heater



Product Features

- 750 / 1500 watts
- All steel construction
- Powder coat paint finish for durable, long lasting service
- Manual reset thermal safety limit
- Illuminated ON/OFF switch
- Two stage thermostat
- 6 foot power cord with molded NEMA 5-15 plug
- Width: 10" Height: 11½" Depth: 6"
- Made in U.S.A.



Back of heater



WARNING: This product can expose you to chemicals including nickel which is known to the State of California to cause cancer, and chromium, which is known to the State of California to cause birth defects and/or reproductive harm. For more information go to www.P65Warnings.ca.gov.



*Rated at 5 feet

Standard Models

MFG CATALOG NUMBER	MFG MODEL NUMBER	VOLTS	WATTS	AMPS	DECIBELS*	WT. (LBS)	LIST
01190802	150TS	120	750 / 1500	12.5	53dBA	9	479

198 Series 120 Volt Radiant and/or Fan Forced Portable Heater

Product Features

- Three heat settings:
 - 600 Watt radiant
 - 900 Watt fan forced
 - 1500 Watt radiant & fan forced
- Temperature control thermostat
- Maximum BTU 5,120
- Imported to TPI Corporation specifications
- Dual safety system:
 - Tip over switch
 - Manual reset type limit control
- 6' long - 3 conductor cord
- 1-year limited warranty
- Width: 11" Height: 15" Depth: 12"



Integrated Automatic Tip-Over Safety Switch



Thermal Overload Protection with Manual Reset



WARNING: This product can expose you to chemicals including nickel which is known to the State of California to cause cancer, and chromium, which is known to the State of California to cause birth defects and/or reproductive harm. For more information go to www.P65Warnings.ca.gov.



Standard Models

MFG CATALOG NUMBER	MFG MODEL NUMBER	WATTS	MAX BTUs	VOLTS	AMPS	PHASE	WT. (LBS)	LIST
04450902	198 TMC	1500 / 900 / 600	5120	120	12.5 / 7.5 / 5	1	9	264

188 Series 120 Volt "Milk-house" Style Fan Forced Portable Heater

Product Features

- 1300W & 1500W heat settings plus fan only setting
- Temperature control thermostat
- 6' long - 3 conductor cord
- Imported to TPI Corporation specifications
- Triple safety system:
 - Tip over switch
 - Automatic reset type limit control
 - Thermal cut-off device
- Width: 10" Height: 16" Depth 9 1/2"

⚠ WARNING: This product can expose you to chemicals including nickel which is known to the State of California to cause cancer, and chromium, which is known to the State of California to cause birth defects and/or reproductive harm. For more information go to www.P65Warnings.ca.gov.



Standard Models

MFG CATALOG NUMBER	MFG MODEL NUMBER	WATTS	MAX BTUs	VOLTS	AMPS	PHASE	WT. (LBS)	LIST
08004102	188 TASA	1500 / 1300	5120	120	12.5 / 10.8	1	9	158

E3915 Series Portable Hydronic Baseboard



⚠ WARNING: This product can expose you to chemicals including nickel which is known to the State of California to cause cancer, and chromium, which is known to the State of California to cause birth defects and/or reproductive harm. For more information go to www.P65Warnings.ca.gov.

Product Features

- Manual reset limit control
- 2 stage thermostat (750 Watt / 1500 Watt)
- Positive On / Off switch
- Heavy duty cabinet construction
- Includes heavy duty carry handle
- Height: 9" Length: 60" Depth: 3"

Standard Models

MFG CATALOG NUMBER	MFG MODEL NUMBER	WATTS	MAX BTUs	VOLTS	AMPS	PHASE	WT. (LBS)	LIST
01186702	E3915-60P	1500/750	5120	120	12.5 / 6.25	1	35	1115

483 Series 120 Volt Portable Baseboard Convection Heater

Product Features

- 1500 Watt convection heater
- Temperature control thermostat
- Manual reset type limit control
- Power on indicator light
- 6' long - 3 conductor cord
- Imported to TPI Corporation specs
- Width: 48"
Height: 5 1/4"
Depth: 7 1/2"



Standard Models

MFG CATALOG NUMBER	MFG MODEL NUMBER	WATTS	MAX BTUs	VOLTS	AMPS	PHASE	WT. (LBS)	LIST
08708802	483 TM	1500	5120	120	12.5	1	13	277

474 Series 240 Volt Dual Heat Fan Forced Portable Heater



- 1920W & 3840W heat settings
- Temperature control thermostat (40°-110° F)
- Manual reset type limit control
- 6' long - 3 conductor cord
- Imported to TPI Corporation specifications

Width: 16"
Height: 16"
Depth: 8 1/2"

⚠ WARNING: This product can expose you to chemicals including nickel which is known to the State of California to cause cancer, and chromium, which is known to the State of California to cause birth defects and/or reproductive harm. For more information go to www.P65Warnings.ca.gov.

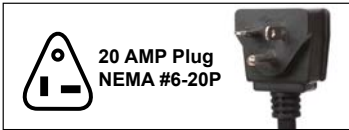

Standard Models

MFG CATALOG NUMBER	MFG MODEL NUMBER	WATTS	MAX BTUs	VOLTS	AMPS	PH	WT. (LBS)	LIST
04461802	H474TM-C	1920/3840	13106	240	8.0 / 16.0	1	20	451

5800 Series Garage/Workshop 240/208 Volt Fan Forced Portable Heater

Product Features

- Up to 4800 Watts of heating comfort for garage or utility room applications
- 4000 Watts available for smaller areas
- Built in bi-metal double pole thermostat 50° to 90°F range
- Steel tubular heating element
- Wall/ceiling bracket included
- Manual reset standard
- Power on and overheat pilot lights
- Imported to TPI Corporation specifications



ITEM	WIDTH	HEIGHT	DEPTH
Heater	10.625"	11"	9.625"
Bracket	2.5"	10"	14.0"

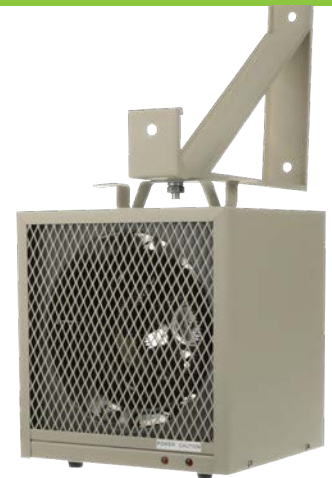
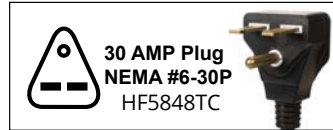
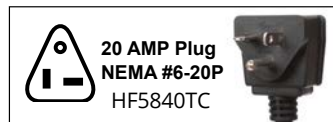

Standard Models

MFG CATALOG NUMBER	MFG MODEL NUMBER	WATTS	MAX BTUs	VOLTS	AMPS	PH	PLUG TYPE	WT. (LBS)	LIST
05034002	HF5840TC	4000/3000	13652	240 / 208	16.6 / 14.4	1	20 Amp	17	399
05033902	HF5848TC	4800/3600	15086	20 / 17.3	20 / 17.3	1	30 Amp	17	507



ICH Series 240/208 Volt Construction Site/Utility Fan Forced Portable Heater

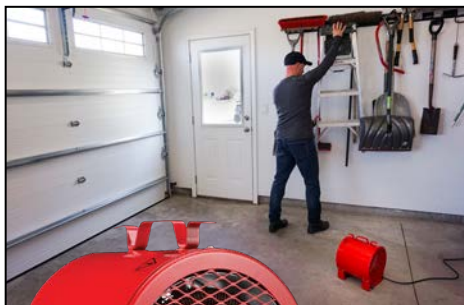

Product Features

- Operates on 240V or 208V
- Steel tubular heating element
- 43°F air heat rise
- Internal overheat thermostat
- Imported to TPI Corporation specifications
- Temperature control thermostat with 60°F-110°F range
- 6' long cordset
- Width: 10 5/8" Height: 12 3/4" Depth: 10"

Standard Models

MFG CATALOG NUMBER	MFG MODEL NUMBER	WATTS	MAX BTUs	VOLTS	AMPS	PH	WT. (LBS)	LIST
04508702	ICH-240C	4000 / 3000	13648	240 / 208	16.7 / 14.4	1	15	405

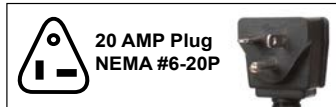

⚠ WARNING: This product can expose you to chemicals including nickel which is known to the State of California to cause cancer, and chromium, which is known to the State of California to cause birth defects and/or reproductive harm. For more information go to www.P65Warnings.ca.gov.

680 Series "Bulldog" 240/208 Volt Fan Forced Portable Unit Heater

Product Features

- Operates on 240V or 208V
- Finned steel tubular heating element
- Internal manual reset thermal cut-out
- 6' long cord with molded plug
- Temperature control thermostat with 60°F-110°F range
- 10' air throw - 262 CFM
- Imported to TPI Corporation specifications
- Width: 13 1/2" Height: 17 1/2" Depth: 11 1/2"

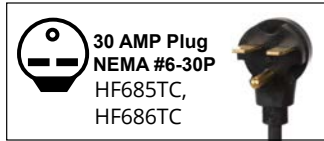
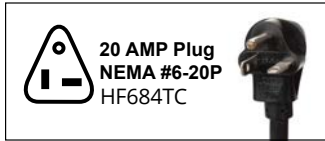

WARNING: This product can expose you to chemicals including nickel which is known to the State of California to cause cancer, and chromium, which is known to the State of California to cause birth defects and/or reproductive harm. For more information go to www.P65Warnings.ca.gov.



Swivel base allows unit to be wall, floor, or ceiling mounted

Standard Models

MFG CATALOG NUMBER	MFG MODEL NUMBER	WATTS	MAX BTUs	VOLTS	PHASE	AMPS	TEMP RISE	WT. (LBS)	LIST	
04462802	*HF684TC	4000/3000	13652/10239	240/208	1	16.7/14.4	48°F	20	635	
04462902	HF685TC	4800/3600	16384/12288	240/208	1	20.0/17.3	58°F	20	667	
04463002	HF686TC	5600/4200	19107/14330	240/208	1	23.3/20.2	75°F	20	747	
06835002	A1560	OPTIONAL WALL CEILING BRACKET FOR HF680 & ICH 240C SERIES HEATERS								123

*HF684TC UL listed only

Specialty Heaters

RPH Series Pump House Convection Specialty Heater

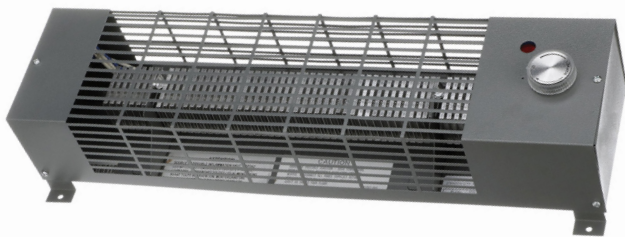

WARNING: This product can expose you to chemicals including nickel which is known to the State of California to cause cancer, and chromium, which is known to the State of California to cause birth defects and/or reproductive harm. For more information go to www.P65Warnings.ca.gov.

Product Features

- Provides protection against freezing for pump houses, utility rooms, relay stations, construction sheds, etc.
- Stainless steel heating element and Aluminum fins
- Automatic temperature control thermostat with a 30°F to 140°F range
- Powder coated epoxy steel case
- Dimension 20" x 5 1/2" x 4"
- Over heat protection thermal fuse
- Made in U.S.A.

Standard Models

MFG CATALOG NUMBER	MFG MODEL NUMBER	WATTS	BTUs	VOLTS	AMPS	WT. (LBS)	LIST
09990802	RPH1-5A	500	1706	120	4.2	5	328
09990902	RPH2-5A	500	1706	240	2.1	5	
International Models							
09842602	RPH22-5Ai	500	1706	220	2.3	5	328

Specialty Heaters

FH Series In-Floor Fan Forced Specialty Heater

Product Features

- Powder coated 20 gauge steel case
- 14 gauge grill
- Steel spiral finned heating element
- Auto reset thermal cut out with visual alarm
- Floor opening: 14 1/8" x 7 1/4" x 7 3/8"
- Grill dimensions: 15 13/16" x 8 13/16"
- Made in U.S.A.



WARNING: This product can expose you to chemicals including nickel which is known to the State of California to cause cancer, and chromium, which is known to the State of California to cause birth defects and/or reproductive harm. For more information go to www.P65Warnings.ca.gov.



Standard Models

MFG CATALOG NUMBER	MFG MODEL NUMBER	WATTS	BTUs	VOLTS	AMPS	WT. (LBS)	LIST
03782302	FH15	750	2560	120	6.25	15	984
		1500	5120	120	12.5		
		1500/1125	5120 / 3840	240/208	6.25/5.41		
OPTIONAL FIELD INSTALLED THERMOSTATS							
03782702	FH1T	Single Pole Integral Thermostat Kit (40°-110°F)				1	248

TSH Series Fan Forced Kickspace Specialty Heater



WARNING: This product can expose you to chemicals including nickel which is known to the State of California to cause cancer, and chromium, which is known to the State of California to cause birth defects and/or reproductive harm. For more information go to www.P65Warnings.ca.gov.

Product Features

- Fits into soffits, stair risers or under utility cabinets
- Finned steel heating element
- Manual reset thermal cut-out
- Recessed opening: 22 3/8" x 3 5/8" x 11 1/2"
- Grill dimensions: 23 7/8" x 3 5/8"
- Zero inch clearance for installation
- Made in U.S.A.

Standard Models

MFG CATALOG NUMBER	MFG MODEL NUMBER	WATTS	BTUs	VOLTS	AMPS	WT. (LBS)	LIST
03818002	TSH20J	1500 / 1000	5120 / 3412	120	12.5 / 8.4	16	561
		1500 / 750	5120 / 2560	208	7.2 / 3.6		
		2000 / 1000	6284 / 3412	240	8.4 / 4.2		
09701702	TSH20JW----	Above Model with White Grill					
OPTIONAL FIELD INSTALLED THERMOSTATS							
03783702	TSH1TX	Single Pole Integral Thermostat Kit (40°-100°F)				1	131
03783802	TSH2TX	Double Pole Integral Thermostat Kit (40°-100°F)				1	

CF-C Series TPI Commercial Air Curtains



Features

- Super thin body, full metal housing
- Cross flow, 2-speed fans
- Adjustable air deflector
- Mechanical control
- Units are 120V at 60Hz

WARNING: This product can expose you to chemicals including nickel which is known to the State of California to cause cancer, and chromium, which is known to the State of California to cause birth defects and/or reproductive harm. For more information go to www.P65Warnings.ca.gov.

Standard Models

MFG CATALOG NUMBER	MFG MODEL NUMBER	WATTS	CFM		FPM		NOISE LEVEL (dB)		DIMENSIONS			WT. (LBS)	LIST
			HIGH	LOW	HIGH	LOW	HIGH	LOW	"L"	"W"	"H"		
08764402	CF35-C	300	1177	942	2560	1968	67	65	35"	8 3/4"	10 1/4"	33.1	617
08764502	CF47-C	350	1648	1295	2560	1968	69	67	47"			43	713
08764602	CF59-C	400	2119	1648	2560	1968	71	69	59"			48.5	854



CF & CFH Series Variable Speed Air Curtains

Product Specifications

CABINET & CONSTRUCTION: Shall be constructed of 20 gauge rigid steel with baked on epoxy powder coat paint for durability. Made in U.S.A.



DISCHARGE VANES: Shall extend the entire width of the unit and be adjustable for optimum performance of air flow.

BLOWERS: Shall be forward curved centrifugal type, DWDI with corrosion resistance scroll and wheel.

WARNING: This product can expose you to chemicals including nickel which is known to the State of California to cause cancer, and chromium, which is known to the State of California to cause birth defects and/or reproductive harm. For more information go to www.P65Warnings.ca.gov.

MOTORS: Shall be heavy duty, PSC, direct drive high efficiency and designed for use with SCR controllers. Motors shall be permanently lubricated for long life and have thermal over load protection. Motor shall have double insulation protection for quieter operation. Quick disconnects shall be supplied to accommodate easy installation and service of motor.

SCR SPEED CONTROLLER: Supplied on all units compatible with the motor with low end adjustment for air volume control and savings in power consumption.

ELECTRIC HEAT (OPTIONAL): Electric heater available as field installed option. Electric heater shall be steel sheath element with helical wound steel fins for maximum heat transfer and safety.

MFG CATALOG NUMBER	SIZE (in)	MFG MODEL NUMBER	FT. / MIN. HI - LOW	NOZZLE CFM	VOLTS	RPM HI - LOW	AMPS HI - LOW	WATTS HI - LOW	WT. (LBS)	LIST	
STANDARD UNITS: 1/2 HP MODELS - UP TO 10' HIGH DOORWAYS - WITHOUT HEAT SECTION											
06712002	36	CF36	3288/455	2672/333	120	1659/620	3.9/3.4	472/154	74	2580	
06712102	48	CF48	4168/786	4515/766		1606/583	4.4/3.6	519/189	82	2796	
06712202	60	CF60	4168/764	6544/931		1636/562	4.4/3.8	509/199	90	3016	
	72	2 EA: CF36	3288/455	5344/666		1659/620	7.8/6.8	944/308	148	5160	
	96	2 EA: CF48	4168/786	9030/1532		1606/583	8.8/7.2	1038/378	164	5592	
	108	3 EA: CF36	3288/455	8016/999		1659/620	11.7/10.2	1416/462	222	7740	
	120	1 EA: CF48	4168/786	9859/1432		1606/583	12.2/10.4	1982/497	230	7956	
		2 EA:CF36	2672/333								
HEAVY DUTY UNITS: 3/4 HP MODELS - UP TO 12' HIGH DOORWAYS - WITHOUT HEAT SECTION											
06712302	36	CFHD36	3288/1120	2672/819		120	1689/603	4.4/4.3	603/192	77	2716
06712402	48	CFHD48	4256/929	4611/906	1662/500		5.9/4.8	586/168	85	2933	
06712502	60	CFHD60	4256/924	5763/1126	1652/509		5.2/4.4	708/172	93	3158	
	72	2 EA: CFHD36	3288/1120	5344/1638	1689/603		8.8/8.6	1206/384	154	5432	
	96	2 EA: CFHD48	4256/929	9222/1812	1662/500		11.8/9.6	1172/336	170	5866	
	108	3 EA: CFHD36	3288/1120	8016/2457	1689/603		13.2/12.9	1809/576	231	8148	
	120	1 EA: CFHD48	4256/929	9955/2544	1662/500		14.7/13.4	2981/552	239	8365	
		2 EA: CFHD36	3288/1120								

EXAMPLE					Use the example shown (left) to order unit with heat section by specification
Model #	Unit Width	KW	Volts	PH	
CFHTR	36	10.0	208	3	



Air Curtain with Heater Module

NOTE: All heating sections are constructed of totally enclosed fin tubular elements for safety and longer operating life. With heating section installed, unit becomes a 24 Volt control unit and can utilize a low voltage thermostat for control of heating.

NOTE: For 72" through 120" units, order multiple heater modules corresponding to the actual air curtain models

MFG MODEL	HEATER WIDTH	KW	VOLTS	PHASE	HEATER AMPS	MINIMUM CIRCUIT AMPS	MAXIMUM FUSE AMPS	BTU/H	75°C WIRE AWG	LIST
	3	208	208	3	8.3	10.4	15	10,239	14	36" - 1974 48" - 2179 60" - 2255
					7.2	9.0	15		14	
					3.6	4.5	15		14	
		480	208	1	10.8	13.5	15		14	
					14.4	18.0	20		12	
					12.5	15.6	20		12	
	5	208	240	3	13.8	17.25	20	17,075	12	
					12.0	15.0	20		12	
					6.0	7.5	15		14	
		480	208	1	18.0	22.5	25		10	
					24.0	30.0	35		8	
					20.8	26.6	30		10	
	7.5	208	240	3	20.8	26.0	30	25,597	10	
					18.0	22.5	25		10	
					9.0	11.3	15		14	
		480	208	1	27.0	33.8	40		8	
					36.0	45.0	50		6	
					31.2	39.0	45		8	
	10	208	240	3	27.7	34.4	40	34,130	8	
					24.0	30.1	35		8	
					12.0	15.0	20		12	
		480	208	1	36.1	45.1	50		6	
					41.6	52.0	60		6	
					33.3	41.6	45		8	
12	208	240	3	28.8	36.0	40	40,956	8		
				14.4	18.0	20		12		
				43.3	54.1	60		6		
	480	208	1	41.6	52.0	60		6		
				36.0	36.0	55		6		
				18.0	18.0	30		10		

ET9 Series - Line Voltage



Features

- Single pole and double pole
- Heat only, cool only, & heat or cool
- DP models include positive off
- Celsius and Fahrenheit temperature scale
- Thermometer standard
- Heating: 22A @120-277VAC resistive
- Cooling: 3/4HP @ 125VAC / 1.5HP @ 250/277 VAC
- Range: 50-90°F (unless otherwise noted)
- Imported to TPI Specifications

MFG CATALOG NUMBER	MFG MODEL NUMBER	DESCRIPTION	RANGE	CONNECTIONS	POS. OFF	LIST
05238302	AET9DWTS*	DPST Heat Only	50-90°F	Wire Leads	Yes	62
05238402	AET9SWTS*	SPST Heat Only	50-90°F	Wire Leads	No	58
05238502	ET9DTS	DPST Heat Only	50-90°F	Terminals	Yes	51
05238602	ET9D4TS	DPST Heat Only	35-75°F	Terminals	Yes	52
05238702	ET9DWTS	DPST Heat Only	50-90°F	Wire Leads	Yes	52
05238802	ET9MTS	2 Stage Heat Only	50-90°F	Terminals	No	54
05238902	ET9STS	SPST Heat Only	50-90°F	Terminals	No	45
05239002	ET9S4TS	SPST Heat Only	35-75°F	Terminals	No	47
05239102	ET9SRTS	SPST Cool Only	50-90°F	Terminals	No	45
05239202	ET9SWTS	SPST Heat Only	50-90°F	Wire Leads	No	51
05239302	ETD9MTS	2 Stage Heat, 1 Stg Cool	50-90°F	Terminals	No	54
05239602	ETD9M4TS	SPDT Heat or Cool	50-90°F	Terminals	No	80
05239402	ETD9STS	SPDT Heat or Cool	50-90°F	Terminals	No	47

*Indicates anticipated models



WARNING: This product can expose you to chemicals including nickel which is known to the State of California to cause cancer, and chromium, which is known to the State of California to cause birth defects and/or reproductive harm. For more information go to www.P65Warnings.ca.gov.

EPET Series and HLT Series Hazardous Location



Features

- SPDT & DPDT Models
- Heat or cool compatible
- Celsius and Fahrenheit temperature scale
- Bi-Metal or capillary sensor
- Snap action switch
- Casting tapped top and bottom for 3/4" conduit
- 1/2" thick cast aluminum housing
- All EPET optional thermostats manufactured with anti-static plastic
- Dimension 5.75" x 6.375" x 5.57"
- Made in U.S.A.

- Motor Rating (full load): 3/4 HP @ 125V, 1-1/2 HP @ 250V
- Pilot Duty Rating 125VA @ 24VAC
- NEMA Class Seven Div. 1 Approved
- Class I Group C & D, Class II Group E, F, & G
- Not rated for Group B

WARNING: This product can expose you to chemicals including nickel which is known to the State of California to cause cancer, and chromium, which is known to the State of California to cause birth defects and/or reproductive harm. For more information go to www.P65Warnings.ca.gov.

MFG CATALOG NUMBER	MFG MODEL NUMBER	DESCRIPTION	LOAD RATINGS	RANGE	LIST
05380702	EPETD8D	DPDT - Bi-Metal	22A @120-277VAC	50-90°F	579
05381002	EPETD8S	SPDT - Bi-Metal	22A @120-277VAC	50-90°F	579
05280702	EPETP8D	DPDT - Bi-Metal	22A @120-480VAC	50-90°F	579
05280602	EPETP8S	SPDT - Bi-Metal	22A @120-480VAC	50-90°F	579
05231502	HLT-1	SPDT - Capillary	22A @120-277VAC	40-110°F	794
05231602	HLT-2	DPDT - Capillary	22A @120-277VAC	40-110°F	838
Master ctn: 4 pcs, 24 lbs (varies slightly by model), 16" x 14.5" x 6"					
EPET Series incorporate plastic knob & Bi-Metal Sensor housing					
HLT Series incorporates screwdriver temperature adjustment slot and all metal housing. External bulb and capillary sensor.					

2000 Series - Line Voltage



Features

- Shadow White or Ivory
- Single pole and double pole
- DP models include positive off
- 22 Amps, 277 Volts AC
- Heat Only / Range: 50-90°F
- Imported to TPI Corporation specifications
- Compliant with RoHS2 Directive (2011/65/EU), that of which includes the application exemptions outlined in Annex III of the directive



WARNING: This product can expose you to chemicals including nickel which is known to the State of California to cause cancer, and chromium, which is known to the State of California to cause birth defects and/or reproductive harm. For more information go to www.P65Warnings.ca.gov.



MFG CATALOG NUMBER	MFG MODEL NUMBER	COLOR	DESCRIPTION	LIST
05028402	S2022H10AA	Shadow White	Single Pole with leads, 22 Amp	60
05024302	S2022H10AB	Ivory	Single Pole with leads, 22 Amp	60
05028502	D2022H10BA	Shadow White	Double pole with leads, 22 Amp	78
05024402	D2022H10BB	Ivory	Double pole with leads, 22 Amp	78
05029102	S2025H10AA	Shadow White	Single Pole with leads, 25 Amp	88
05029202	D2025H10BA	Shadow White	Double pole with leads, 25 Amp	102

TW Series

Features

- Single and double pole models
- Wire leads
- Tamper resistant
- Compliant with RoHS2 Directive (2011/65/EU), that of which includes the application exemptions outlined in Annex III of the directive
- Imported to TPI Corporation specifications



MFG CATALOG NUMBER	MFG MODEL NUMBER	DESCRIPTION	TEMPERATURE SCALE	LIST
05020002	TW145	SP, Beige with Leads	Tamper Resistant / 50-90°F	101
05020102	TW146	DP, Beige with Leads	Tamper Resistant / 50-90°F	118
Master Carton: 25 Pcs, 12 lbs. (varies slightly by model), 16" x 14" x 5.5"				

WARNING: This product can expose you to chemicals including nickel which is known to the State of California to cause cancer, and chromium, which is known to the State of California to cause birth defects and/or reproductive harm. For more information go to www.P65Warnings.ca.gov.

Washdown Series

Features

- Single and double pole models
- Rain tight NEMA 4X rating
- Stainless steel hardware
- Coil capillary temperature sensor
- Made in U.S.A. with domestic and foreign components

MFG CATALOG NUMBER	MFG MODEL NUMBER	DESCRIPTION	TEMPERATURE SCALE	CONNECTION	LIST
05234202	TW155A	SPDT Heat or Cool	40-110°F	6" Wire Leads	297
05234302	TW255A	DPDT Heat or Cool	40-110°F		344
22 Amps Resistive @ 120/250/277 VAC, 5" x 5" x 3" Case					

MFG CATALOG NUMBER	MFG MODEL NUMBER	DESCRIPTION	TEMPERATURE SCALE	CONNECTION	LIST
05234502	CTW155B	SPST Heat Only	40-110°F	6' Cord	317
05234602	CTW155C	SPST Cool Only	40-110°F		363
13 Amps @ 125 VAC Res. / 58.8 LRA @ 125 VAC / 9.8 FLA @ 125 VAC					



TW

CTW

WARNING: This product can expose you to chemicals including nickel which is known to the State of California to cause cancer, and chromium, which is known to the State of California to cause birth defects and/or reproductive harm. For more information go to www.P65Warnings.ca.gov.



Industrial Series

Features

- Coil capillary (CKT) models
- Bi-Metal models (KT)
- Rugged steel case
- SPST & SDPT models
- Compliant with RoHS2 Directive (2011/65/EU), that of which includes the application exemptions outlined in Annex III of the directive. (KT models only)
- Hard wired models rated for 22A resistive @125-250 VAC
- Corded models rated for 13A resistive @125VAC
- Imported to TPI Corporation specifications

MFG CATALOG NUMBER	MFG MODEL NUMBER	DESCRIPTION	RANGE	CONNECTIONS	SCALE	LIST
05340402	CKTD110	SPDT Heat or Cool	40 - 110°F	Wire Leads	F	183
05340202	CKT121	SPST Heat Only	40 - 110°F	6' Cord/Plug	F	224
05340502	CKT0121	SPST Cool Only	40 - 110°F	6' Cord/Plug	F	251
05340802	KT110	SPST Heat Only	-10 - 100oF	Wire Leads	C & F	78
05341002	KT121	SPST Heat Only	-10 - 100oF	6' Cord/Plug	C & F	86
05341702	KTD110	SPDT Heat or Cool	-10 - 100oF	Wire Leads	C & F	78
05343602	KTO110	SPST Cool Only	-10 - 100oF	Wire Leads	C & F	78
05342102	KTO121	SPST Cool Only	-10 - 100oF	6' Cord/Plug	C & F	86
Master Carton: 13.75" x 14" x 9", Qty 9-12, 14lbs.-16lbs. depending on model						



WARNING: This product can expose you to chemicals including nickel which is known to the State of California to cause cancer, and chromium, which is known to the State of California to cause birth defects and/or reproductive harm. For more information go to www.P65Warnings.ca.gov.

Thermostats & Controls

Honeywell Line Voltage Thermostats

WARNING: This product can expose you to chemicals including nickel which is known to the State of California to cause cancer, and chromium, which is known to the State of California to cause birth defects and/or reproductive harm. For more information go to www.P65Warnings.ca.gov.

Features

- Heat only thermostats
- Accurate temperature control
- 22 Amp resistive for mechanical models



T4398A 1021
Precision Mechanical

Standard Models

MFG CATALOG NUMBER	MFG MODEL NUMBER	VOLTAGE	DIMENSIONS	DESCRIPTION	LIST
05033002	T4398A 1021	120-240	2.875"x4.375"x2.00D	Precision Electric Heating, SPST, 50-80°F, 22 Amp @ 120-240V, 19 Amp @ 277V	102

Programmable Honeywell Line Voltage Thermostat

WARNING: This product can expose you to chemicals including nickel which is known to the State of California to cause cancer, and chromium, which is known to the State of California to cause birth defects and/or reproductive harm. For more information go to www.P65Warnings.ca.gov.

Features

- Heat only thermostats
- Accurate temperature control
- 16 Amp resistive for electronic models
- Energy Star compliant



TL8230A 1003
Electronic Programmable

Standard Models

MFG CATALOG NUMBER	MFG MODEL NUMBER	VOLTAGE	DIMENSIONS	DESCRIPTION	LIST
05033602	TL8230A 1003	240/208	2.70"x4.90"x.90D	Electronic Programmable Line Voltage DPST, 15 Amp, 40-86°F	297

UT Series - Low Voltage

Features

- Vertical or horizontal mounting
- Long life sealed contacts
- Does not contain Mercury
- Leveling not required
- Fahrenheit and Celsius temperature scales
- Compliant with RoHS2 Directive (2011/65/EU), that of which includes the application exemptions outlined in Annex III of the directive
- 2-3°F rated differential
- Anticipator (except UT9001)
- Imported to TPI Corporation specifications

WARNING: This product can expose you to chemicals including nickel which is known to the State of California to cause cancer, and chromium, which is known to the State of California to cause birth defects and/or reproductive harm. For more information go to www.P65Warnings.ca.gov.



MFG CATALOG NUMBER	MFG MODEL NUMBER	DESCRIPTION	VOLTAGE	TERMINALS	SWITCHES	ANTICIPATOR	LIST
05230502	UT1001	Heat Only	24VAC or MV	R & W	None	Yes	34
05230602	UT3001	Cool Only	24 VAC	R, Y & G	Cool/Off Fan/Auto	Yes	34
05230702	UT8001	Heat/Cool	24 VAC	RC, RH, W, Y, & G	Heat/Off/Cool Fan/Auto	Yes	35
05231102	UT9001*	Heat Only	Millivolt	R & W	None	No	34

Master Carton: 50 pcs, 17 lbs, 19" x 11.5" x 9"



*Not UL Listed

RK Series - Low Voltage

Features

- Heat only models
- Positive off
- 2-3°F rated differential
- Compliant with RoHS2 Directive (2011/65/EU), that of which includes the application exemptions outlined in Annex III of the directive
- Does not contain Mercury
- Leveling not required
- Long life sealed contacts
- Fahrenheit and Celsius
- Imported to TPI Corporation specifications



WARNING: This product can expose you to chemicals including nickel which is known to the State of California to cause cancer, and chromium, which is known to the State of California to cause birth defects and/or reproductive harm. For more information go to www.P65Warnings.ca.gov.

Standard Models

MFG CATALOG NUMBER	MFG MODEL NUMBER	DESCRIPTION	VOLTAGE	RANGE	ANTICIPATOR	LIST
05260102	RK120EAA	Heat Only	24VAC or MV	50°-90°F	Yes	33
05262002	RK124EAA	Heat Only	24VAC or MV	35°-75°F	Yes	33
05260502	RK130EAA*	Heat Only	Millivolt	50°-90°F	No	28
05263202	RK134EAA*	Heat Only	Millivolt	35°-75°F	No	28
05261402	RKWP1AA*	Wall Plate	NA	NA	NA	8

Master Carton: 100 Pcs, 24 lbs, 16.5" x 15" x 8"

*Not UL Listed

Pro Series - Digital Non-Programmable Multi-Stage Thermostat



WARNING: This product can expose you to chemicals including nickel which is known to the State of California to cause cancer, and chromium, which is known to the State of California to cause birth defects and/or reproductive harm. For more information go to www.P65Warnings.ca.gov.

Features

- Non-programmable
- Hard wired or battery powered option
- Horizontal or vertical mount
- 2 heat / 1 cool (heat pump)
- 4 sq. inch display
- Blue backlight
- Easy access battery compartment
- Electric or gas configurable
- Filter change indicator (selectable on or off)
- Room temperature calibration adjustment

MFG CATALOG NUMBER	MFG MODEL NUMBER	VOLTAGE	DESCRIPTION	TEMP RANGE	LIST
07425202	PRO1 T721	24V	Digital Non-Programmable, Multi-Stage Thermostat	44°F - 90°F	155

L Series - Line Voltage Thermostat for Duct Heaters



WARNING: This product can expose you to chemicals including nickel which is known to the State of California to cause cancer, and chromium, which is known to the State of California to cause birth defects and/or reproductive harm. For more information go to www.P65Warnings.ca.gov.



Features

- HP Ratings: 120 VAC | ½ HP @ 250 VAC
- 25 Amp resistive max
- Designed for use as temperature operating or regulating controls.
- The bulb and capillary-type sensing element allows remote temperature regulation of heating or cooling applications.
- Temperature range: 0°-90°F

MFG CATALOG NUMBER	MFG MODEL NUMBER	DESCRIPTION	VOLTAGE	RESISTIVE LOAD	TEMP RANGE	LIST
05342702	L08Y-01	Line voltage thermostat for duct heaters	125/240/480	25A	0°-90°F	152

Low Voltage Relays

Features

- Snap action switch
- ½" male conduit spud
- 45 second average time delay
- Temperature range - 50 - 90°F
- Built-In transformer

WARNING: This product can expose you to chemicals including nickel which is known to the State of California to cause cancer, and chromium, which is known to the State of California to cause birth defects and/or reproductive harm. For more information go to www.P65Warnings.ca.gov.



Two switch unit shown

Standard Models

MFG CATALOG NUMBER	MFG MODEL NUMBER	PRIMARY VOLTAGE	RESISTIVE LOAD	DESCRIPTION	LIST
05349202	RC840T-120/U	120V	22A	Single switch, single throw with in-built transformer for remote mounting.	338
05349102	RC840T-240/U	208/240V	22A		321
05349002	RC840T-277/U	277V	19A	Single switch, single throw with in-built transformer for remote mounting.	338
02601002	24A06G-1	240V	25A		501

Note: 277/24V relay available, consult factory.



Electromechanical De-Humidistat



WARNING: This product can expose you to chemicals including nickel which is known to the State of California to cause cancer, and chromium, which is known to the State of California to cause birth defects and/or reproductive harm. For more information go to www.P65Warnings.ca.gov.

Features

- 7.5 amp @ 125VAC
- 3.75 amp @ 240VAC
- 50VA @ 24VAC - 240VAC
- 20% - 80% relative humidity range

Standard Models

MFG CATALOG NUMBER	MFG MODEL NUMBER	DESCRIPTION	LIST
05390602	H46C1166	Dehumidistat / Electromechanical	243

LB Series - Bi-Metal In-Built Thermostats

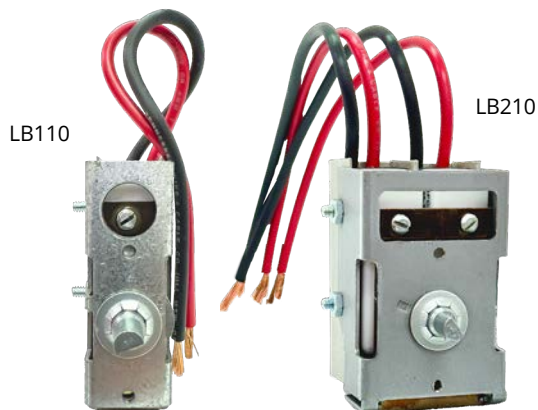

Features

- Bi-Metal sensor
- HP Ratings: 3/4HP @ 125 VAC - 1.5HP @ 250-277 VAC
- 22 Amps resistive max



WARNING: This product can expose you to chemicals including nickel which is known to the State of California to cause cancer, and chromium, which is known to the State of California to cause birth defects and/or reproductive harm. For more information go to www.P65Warnings.ca.gov.

MFG CATALOG NUMBER	MFG MODEL NUMBER	DESCRIPTION	VOLTAGE	RANGE	CONNECTIONS	LIST
05361302	LB110	SPST Heat Only	120-277 VAC	0 - 110°F	6" - 14 gauge Leads	44
05362002	LB210	DPST Heat Only			6" - 14 gauge Leads	57

Master Carton: 16" x 14.5" x 6", Qty 25-50, 11 lbs. - 14 lbs. depending on model

LR Series - Bi-Metal Outdoor Thermostats

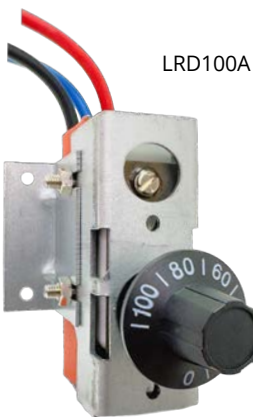

Features

- Bi-Metal sensor
- HP Ratings: 3/4HP @ 125 VAC-1.5HP @ 250-277 VAC
- 22 Amps resistive max

WARNING: This product can expose you to chemicals including nickel which is known to the State of California to cause cancer, and chromium, which is known to the State of California to cause birth defects and/or reproductive harm. For more information go to www.P65Warnings.ca.gov.

MFG CATALOG NUMBER	MFG MODEL NUMBER	DESCRIPTION	VOLTAGE	RANGE	CONNECTIONS	LIST
05363002	LRD100A	SPDT Heat/Cool	120-277 VAC	0 - 110°F	6" - 14 Gauge Leads	38

Master Carton: 16" x 14.5" x 6", Qty 50, 15 lbs. - 16 lbs. depending on model

RH Series - Air Flow / Differential Pressure Switch Controls

Features

- Senses pressure or vacuum
- Adjustable or fixed pressure
- Compliant with RoHS2 Directive (2011/65/EU), that of which includes the application exemptions outlined in Annex III of the directive
- Automatic reset
- Tube, barbed, or compression fittings



RH1505D0

RH3, RH35, RH3A



WARNING: This product can expose you to chemicals including nickel which is known to the State of California to cause cancer, and chromium, which is known to the State of California to cause birth defects and/or reproductive harm. For more information go to www.P65Warnings.ca.gov.

MFG CATALOG NUMBER	MFG MODEL NUMBER	PRESSURE SET	VOLTAGE	RANGE	CONNECTIONS	LIST
05460702	RH1505D0	Fixed	120-277 VAC	0.05" WC	Tube (both sides)	66
05462102	RH3	Adjustable		0.05" - 12" WC	Barbed (both sides)	96
05462302	RH35	Adjustable		0.05" - 2.0" WC	Barbed (both sides)	96
05463102	RH3A	Adjustable		0.05" - 12" WC	Compression (both sides)	86

Master Carton (RH1505D0): 25.5" x 17.75" x 13.5", Qty 48, 36 lbs.
 Master Carton (RH3, RH35, RH3A): 15.25" x 15" x 14", Qty 24, 28-32lbs depending on model

Pilot Tubes (for RH Series Air Flow / Differential Pressure Switch Controls)

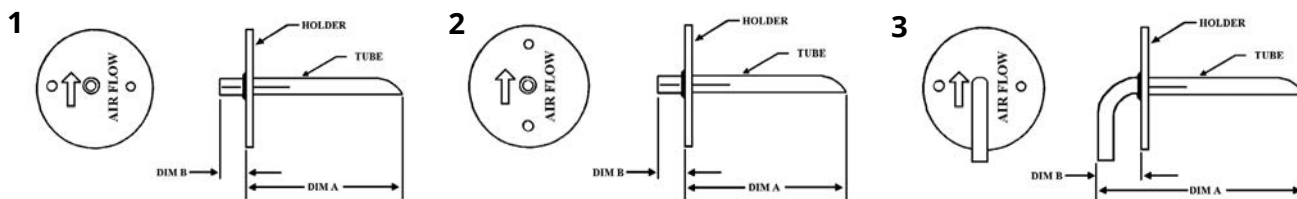

MFG CATALOG NUMBER	MFG MODEL NUMBER	"A" DIMENSION	"B" DIMENSION	FIGURE #	LIST
94228027	61-01730-00	4.29"	0.69"	1	18
94227003	61-01730-003	6.69"	0.69"	1	
94228000	61-01729-00	4.00"	0.50"	2	
94228020	61-01729-20	2.00"	0.50"	2	
94228021	61-01729-21	1.50"	0.50"	2	
94228022	61-01729-22	6.00"	0.50"	2	
94227000	61-01729-27	3.50"	0.50"	3	

WARNING: This product can expose you to chemicals including nickel which is known to the State of California to cause cancer, and chromium, which is known to the State of California to cause birth defects and/or reproductive harm. For more information go to www.P65Warnings.ca.gov.

TG Series Thermostat Guards

Standard Models



Features

- 8 tumbler locks
- Imported to TPI specifications

MFG CATALOG NUMBER	MFG MODEL NUMBER	DESCRIPTION	LIST
05891202	TG1	Plastic Stat Guard/ 6.25" x 4.25" x 3.25" Opening	59
05891002	TG1B	Metal Stat Guard/ 5.25" x 4.625" x 3" Opening	104
05891302	TG2	Plastic Stat Guard/ 5.25" x 5.25" x 3.25" Opening	66
05891102	TG3	Plastic Stat Guard/ 8.125" x 5.37" x 3.25" Opening	66
05891702	TG3B	Metal Stat Guard/ 6.75" x 4.50" x 3.50" Opening	132
05236102	TG4	Plastic Stat Guard / 3.75" x 3.937" x 1.75" Opening	66
05236202	TG5	Plastic Stat Guard / 5" x 3.31" x 1.75" Opening	66
05236302	TG6	Plastic Stat Guard / 5.75" x 4.625" x 1.75" Opening	66

Accessories

MFG CATALOG NUMBER	MFG MODEL NUMBER	DESCRIPTION	HP	CFM / RPM	MAX AMPS	VOLTS	WT. (LBS)	LIST
03976302	TAT-24-FAN-120V-1	Thermal Area Treatment Floor Fan	1/3	5000/1160	3.1	120	30	532

MFG CATALOG NUMBER	MFG STYLE MODEL NUMBER	DESCRIPTION	KW	BTUs	VOLTS	PHASE	AMPS	TEMP RISE	WT. (LBS)	LIST
03981902	TAT-30/1T	30KW Salamander	30	102390	480	3	36	43	115	4152
03982002	TAT-45/1T	45KW Salamander	45	153585	480	3	54.2	70	125	6864

Product Dimensions

TAT 30-45

- Safety yellow heater enclosure with safety screens on both air intake and output openings
- Optional 25' long SO type cord, ready for plug attachment is available for each model
- Long-life finned tubular heating elements
- Thermostat adjustment 115° to 150° F
- Two 10" rear wheels and a front locking caster
- High-limit thermal cutout switch with manual reset
- 2200 CFM
- Fan only operation feature
- Made in U.S.A.



TAT-24-FAN-120V-1

- Single speed
- Head tilts 360°
- Coated steel guards
- SJT type 3 conductor
- Steel hub / Aluminum blades
- Meets OSHA standards
- Made in U.S.A. with domestic and foreign components

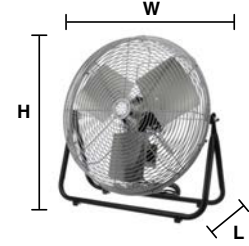

MFG MODEL NUMBER	DIMENSIONS			WT. (LBS)
	LENGTH	WIDTH	HEIGHT	
TAT 30, 45	37"	24"	39"	115/125
TAT24-FAN-120V-1	10.5"	26"	26"	30

⚠ WARNING: This product can expose you to chemicals including nickel which is known to the State of California to cause cancer, and chromium, which is known to the State of California to cause birth defects and/or reproductive harm. For more information go to www.P65Warnings.ca.gov.

HR Series Hot Room Heaters

MFG CATALOG NUMBER	MFG MODEL NUMBER	VOLTAGE - PHASE	KW HEATING	CABINET DIMENSIONS H X W X L (IN)	MOTOR HP	TOTAL AMPS	CFM	TEMP RISE	LIST
03967302	HR-F1-7	208 / 1	7	18 x 22 x 36	1/3	36	1800	13.4	15029
03967402	HR-F3-8.5	208 / 3	8.5	18 x 22 x 36	1/3	25	1800	16.3	15029
03967502	HR-F3-12.2	208 / 3	12.2	18 x 22 x 36	1/3	35	1800	23.4	15029
03967602	HR-H1-8.1	240 / 1	8.1	18 x 22 x 36	1/3	36	1800	15.5	15029
03967702	HR-H3-8.5	240 / 3	8.5	18 x 22 x 36	1/3	23	1800	16.3	15029
03967802	HR-H3-14.1	240 / 3	14.1	18 x 26 x 36	3/4	36	2200	22.1	15802
03967902	HR-P3-10.0	480 / 3	10.0	18 x 22 x 36	3/4	14	1800	19.2	15029
03968002	HR-P3-15.0	480 / 3	15.0	18 x 26 x 36	3/4	20	2200	23.5	15802
03968102	HR-P3-20.0	480 / 3	20.0	18 x 26 x 36	3/4	26	2200	31.4	15802
03968202	HR-P3-24.0	480 / 3	24.0	18 x 26 x 36	3/4	31	2200	43.9	15802
03968302	HR-P3-20.0-2	480 / 3	20.0	18 x 26 x 36	3/4	26	2200	31.4	16706
44597001	Remote Stat	24V	1-stage	w/8' cap.		Range up to 150°F			531
44597002	Remote Stat	24V	2-stage	w/8' cap.		Range up to 150°F			750

Specifications and Additional Information

- High-temperature rated, ball bearing motor; forward curved centrifugal blower; standard with airflow switch, temperature limit controls (manual and automatic resets), and lockable disconnect switch with fuse block
- Galvanized 20-gauge heavy-duty metal housing
- Totally enclosed, finned tubular stainless steel heating elements, provide the benefits of closer temperature regulation, less chance of shock hazards, less susceptibility for shorting, easy service, and will better withstand physical abuse
- Capability of mounting for in-room use, or mounting at an external wall/ceiling, with the heat inlet/outlet ducted to/from the room. 1" duct flanges at inlet and discharge ends are standard, to provide for ducting on the unit
- All models listed are designed for permanent mounting and hard wiring
- A typical hot room should be totally enclosed, with provisions made to keep air from escaping, other than the air being ducted thru the heater itself when the unit is mounted outside the room. As always, insulation should be considered for walls and ceiling, to maximize energy efficiency and heater performance.



⚠ WARNING: This product can expose you to chemicals including nickel which is known to the State of California to cause cancer, and chromium, which is known to the State of California to cause birth defects and/or reproductive harm. For more information go to www.P65Warnings.ca.gov.

Hotpod® Supplemental Duct Mounted Heating System

HotPod - Features

- Use to heat cold rooms or additions without upgrading central system
- Fan only operation for increased cfm output for A/C cycles
- 6" 1000/500 Watt and 8" 1440/720 Watt models available
- Two stage operation
- 120V corded and hard wire models available
- 10' Cord length on corded models
- Zero clearance for all models
- All models include UT8003 low voltage thermostat
- Optional wireless thermostat
- Silent boot option available for rigid duct applications only
- Made in U.S.A. with domestic and foreign components
- Patented: Patent No. 8,285,127, 8,625,976, 8,787,738



WARNING: This product can expose you to chemicals including nickel which is known to the State of California to cause cancer, and chromium, which is known to the State of California to cause birth defects and/or reproductive harm. For more information go to www.P65Warnings.ca.gov.

Standard HotPod® Models

MFG CATALOG NUMBER	MFG MODEL NUMBER	DESCRIPTION	WATTS	VOLTS	MIN.CIRC. SIZE (AMP)	TEMP RISE (F)	WT. (LBS)	RPM	CFM	NEMA PLUG	DIMENSION L x W x H (In.)	LIST
02900702	HP6-1000120-2T	6" INLET, HARDWIRE	1000/500	120	8.33	26	4	1500	130	NA	10 ½ x 8 ½ x 6	815
02900402	HP6-1000120-2CT	6" INLET, WITH CORD SET	1000/500	120	8.33	26	4	1500	130	5-15P	10 ½ x 8 ½ x 6	856
02900802	HP8-1440120-2T	8" INLET, HARDWIRE	1440/720	120	12.6	23	6	1500	210	NA	11 x 10 ½ x 8	995
02900602	HP8-1440120-2CT	8" INLET, WITH CORD SET	1440/720	120	12.6	23	6	1500	210	5-15P	11 x 10 ½ x 8	1054

SilentBooster® Supplemental Duct Mounted Boosting System

SilentBooster® - Features

- 120V corded and hardwire models available
- Adds 120 CFM Boost to duct heating or ventilation applications
- Can utilize optional TPI SilentBoot™ for whisper quiet operation in rigid duct application
- 14" of duct, 4' from register is all that is needed for installation
- Optional wireless thermostat can be utilized to control SilentBooster to increase room comfort

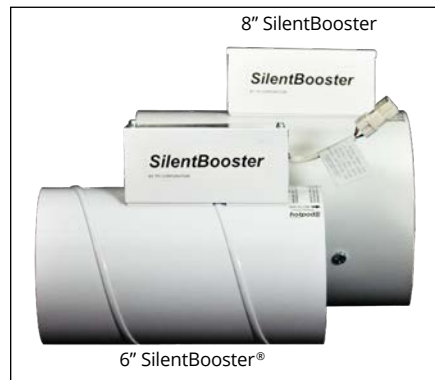

Moisture Control System - Features

- 120V, 8" Ducted Booster Fan; De-humidistat included
- Includes all ductwork and outside damper / 6" to 8" adapters available
- Uses Heavy Duty booster fan to eliminate humidity from basements, crawl spaces, or damp areas
- Made in U.S.A. with foreign and domestic componets

WARNING: This product can expose you to chemicals including nickel which is known to the State of California to cause cancer, and chromium, which is known to the State of California to cause birth defects and/or reproductive harm. For more information go to www.P65Warnings.ca.gov.

Standard SilentBooster® Models

MFG CATALOG NUMBER	MFG MODEL NUMBER	DESCRIPTION	VOLTS	MIN.CIRC. SIZE (AMP)	WT. (LBS)	RPM	CFM	NEMA PLUG	DIMENSION L x W x H (In.)	LIST
02903702	SB6-120-T	6" SilentBooster (Hardwire)	120	15	4	1500	130	NA	10 ½ x 8 ½ x 6	359
02903802	SB6-120-CT	6" SilentBooster (w/Cord Set)	120	15	4	1500	130	5-15P	10 ½ x 8 ½ x 6	397
02903902	SB8-120-T	8" SilentBooster (Hardwire)	120	15	4	1500	210	NA	11 x 10 ½ x 8	397
02904002	SB8-120-CT	8" SilentBooster (w/Cord Set)	120	15	4	1500	210	5-15P	11 x 10 ½ x 8	438
MOISTURE CONTROL SYSTEM										
02904102	MCS120-8CT	8" Moisture Control System	120	15	4	1500	210	5-15P	11 x 10 ½ x 8	557

Hotpod Accessories And Thermostat

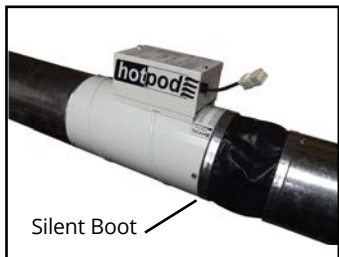

Silent Boot

WARNING: This product can expose you to chemicals including nickel which is known to the State of California to cause cancer, and chromium, which is known to the State of California to cause birth defects and/or reproductive harm. For more information go to www.P65Warnings.ca.gov.

MFG CATALOG NUMBER	MFG MODEL NUMBER	DESCRIPTION	WT. (LBS)	LIST
02900902	SB-6*	6" SILENT BOOT	4	60
02901002	SB-8*	8" SILENT BOOT	4	101
05235702	RFKIT-5	WIRELESS TRANSMITTER	6	328



*Can be used with Hotpod models as a noise attenuator

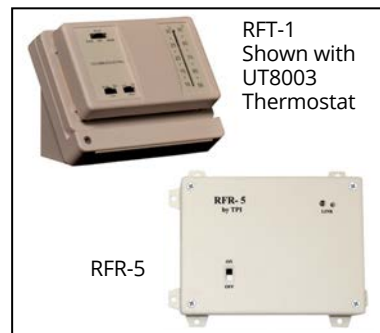

RFT-1 Shown with UT8003 Thermostat

RFR-5

RFKIT-5 - Patent Pending

Hotpod Ready-Pack Self Contained Systems

Features

- Includes all you need to install a complete Hotpod system
- Ideal for room or office additions
- RF Thermostat is standard with our Ready-Pack models, simplifying installation even further - eliminates the need for thermostat wiring
- Same specifications for 6" & 8" Hotpod models apply to Ready-Pack models

WARNING: This product can expose you to chemicals including nickel which is known to the State of California to cause cancer, and chromium, which is known to the State of California to cause birth defects and/or reproductive harm. For more information go to www.P65Warnings.ca.gov.



Ready-Pack self contained system

Note: does not mount to existing duct work.

What's Included

- 6" or 8" Hotpod with RFKIT-5 wireless thermostat and transmitter
- One outlet and one return air grill
- Two 90 degree elbows
- Flexible duct (12.5')
- 8" models include 2 reducers - 8" to 6"

MFG CATALOG NUMBER	MFG MODEL NUMBER	DESCRIPTION	LIST
02902702	HP6-1000120-2TRP	6" INLET, 1000W, 120V, READY-PACK	1810
02902802	HP6-1000120-2CTRP	6" INLET, 1000W, 120V, READY-PACK WITH CORDSET	1907
02902902	HP8-1440120-2TRP	8" INLET, 1440W, 120V, READY-PACK	2145
02903002	HP8-1440120-2CTRP	8" INLET, 1440W, 120V, READY-PACK WITH CORDSET	2209

MFH Series Hotpod - For those LARGER areas



WARNING: This product can expose you to chemicals including nickel which is known to the State of California to cause cancer, and chromium, which is known to the State of California to cause birth defects and/or reproductive harm. For more information go to www.P65Warnings.ca.gov.

Features

- For units supplied with cord: 120V 6' with NEMA 5-15P plug; 240V 6' with NEMA 6-15P plug
- Unit contains air flow switch
- Zero inch (0") clearance installation
- All units are shipped with our UT8003 low voltage thermostat
- All units obtain a 33 degree temperature rise
- RP models are Ready-Pack models and do not need existing duct work
- Made in U.S.A.

Standard Models

MFG CATALOG NUMBER	MFG MODEL NUMBER	DESCRIPTION	WATTS	VOLTS	WT. (LBS)	CFM	RPM	LIST
02901302	MFHE-0300-6-EAA	6" INLETS, 1500 W, 120V, 2 STAGE THERMOSTAT	1500	120	132	250	1500	2234
02901902	MFHE-0300-6-EAARP	UNIT ABOVE WITH FLEX, BOOTS, GRILLS	1500	120	145	250	1500	2987
02901402	MFHE-0300-6-EAAC	6" INLETS, 1500 W, 120V, 2 STAGE THERMOSTAT, CORD	1500	120	132	250	1500	2301
02902002	MFHE-0300-6-EAACRP	UNIT ABOVE WITH FLEX, BOOTS, GRILLS	1500	120	145	250	1500	3050
02901702	MFHE-0300-6-HAA	6" INLETS, 2000W, 240V, 2 STAGE THERMOSTAT	2000	240	132	250	1500	2363
02902302	MFHE-0300-6-HAARP	UNIT ABOVE WITH FLEX, BOOTS, GRILLS	2000	240	145	250	1500	3114
02901502	MFHE-0300-8-EAA	8" INLETS, 1500W, 120V, 2 STAGE THERMOSTAT	1500	120	135	250	1500	2276
02902102	MFHE-0300-8-EAARP	UNIT ABOVE WITH FLEX, BOOTS, GRILLS, REDUCERS	1500	120	148	250	1500	3198
02901602	MFHE-0300-8-EAAC	8" INLETS, 1500W, 120V, 2 STAGE THERMOSTAT, CORD	1500	120	135	250	1500	2341
02902202	MFHE-0300-8-EAACRP	UNIT ABOVE WITH FLEX, BOOTS, GRILLS, REDUCERS	1500	120	148	250	1500	3265
02901802	MFHE-0300-8-HAA	8" INLETS, 3000W, 240V, 2 STAGE THERMOSTAT	3000	240	135	250	1500	2428
02902402	MFHE-0300-8-HAARP	UNIT ABOVE WITH FLEX, BOOTS, GRILLS, REDUCERS	3000	240	148	250	1500	3351

Fresh Air Make Up Units - Features

- Can be used with existing systems for fresh air intake
- Includes replaceable filter
- All units include duct stat and disconnect switch
- Available with 6" inlet and outlet only

Standard Models

MFG CATALOG NUMBER	MFG MODEL NUMBER	DESCRIPTION	CFM	RPM	LIST
02902502	MFHE-0300-6-HAAF2D	6" INLETS, 3000W, 240V, FILTER, DUCT STAT	250	1500	3010
02902602	MFHE-0300-6-FAAF2D	6" INLETS, 2000W, 208V, FILTER, DUCT STAT	250	1500	2919

5700 Series Confined Space Plenum Rated Heater

Features

- Easily fits between joists for typical installation
- Zero clearance for wall and ceiling mounting as well as floor mounting with appropriate inlet and outlet clearances
- Bracket standard or can be mounted by 3/8" threaded rod (field supplied)
- Automatic reset thermal limit for safety
- 1-Phase model wattage field changeable from 1874 to 5000 Watts
- 24V control circuit on three phase models with hydraulic thermostat
- Made in U.S.A

**5700 Series Confined Space Plenum Rated Heater can also be found on page 24, including product dimensions



WARNING: This product can expose you to chemicals including nickel which is known to the State of California to cause cancer, and chromium, which is known to the State of California to cause birth defects and/or reproductive harm. For more information go to www.P65Warnings.ca.gov.



Standard Models

MFG CATALOG NUMBER	MFG MODEL NUMBER	WATTS	BTUs	VOLTS	PHASE	AMPS	TEMP RISE	TEMP RANGE	AIR THROW	CFM	WT. (LBS)	LIST
07262402	HF5705T	5000	17065	240	1	21	57°F	(40°F-120°F)	16'	275	32	1276
		4165	14215	240	1	17	48°F	(40°F-120°F)	16'	275	32	1276
		3332	11365	240	1	14	38°F	(40°F-120°F)	16'	275	32	1276
		2500	8533	240	1	10	29°F	(40°F-120°F)	16'	275	32	1276
		3750	12798	208	1	18	43°F	(40°F-120°F)	16'	275	32	1276
		3123	10659	208	1	15	36°F	(40°F-120°F)	16'	275	32	1276
		2500	8553	208	1	12	29°F	(40°F-120°F)	16'	275	32	1276
07262502	H3H5705T	3750	12799	208	3	10.4	57°F	(40°F-110°F)	16'	275	32	1375
		5000	17065	240	3	12	57°F	(40°F-110°F)	16'	275	32	1375
07262602	P3P5705T	5000	17065	480	3	6	57°F	(40°F-110°F)	16'	275	32	1375
07073602	DCS-MT303	Optional Field Installed Disconnect Switch, 30 Amp @ 600Volts										118

7200 Series Plenum Heater

HOW TO DESIGNATE A MODEL:

F	3	E	72	15	2	T
Element Voltage G = 277V P = 480V H = 240V F = 208V	Phase 3 = Three Phase 1 = Single Phase	Motor Voltage G = 277V P = 480	Series Number	Element KW 3KW through 50KW See model chart for KW options.	Heater Stages Blank = One 2 = Two	Control System T = Unit Thermostat SSR = SSR Control Blank = None



WARNING: This product can expose you to chemicals including nickel which is known to the State of California to cause cancer, and chromium, which is known to the State of California to cause birth defects and/or reproductive harm. For more information go to www.P65Warnings.ca.gov.

*SSR proportional control maximum: 45 Amps

**SSRs require a 0-10vDC, 4-20mA, or 0-135Ω field supplied signal or an optional VT7225 thermostat

Product Specifications

- 20 gauge galvanized cabinet
- Variable speed motor, factory set at maximum
- Motor speed can be field adjusted to increase heat rise
- Acoustically insulated with 1" fiberglass
- Access panels on both sides of cabinet
- 24 Volt controls. / disconnect switch
- Air flow switch
- Terminal blocks
- 0" Clearance on sides, top, and bottom
- Single point connection
- Dust tight control enclosure
- Filter rack on inlet with throw away filter
- Inlet and outlet screens and duct connection
- Automatic primary limit control and secondary fuse link
- Optional wall thermostat, unit thermostat or SSR control which proportionally regulates heat output
- Made in U.S.A.

7200 Series Plenum Heater

7200 Series Plenum Heater Standard Models

MFG CATALOG NUMBER	MFG MODEL NUMBER	KW	CFM RANGE	VOLTS / PHASE	TOTAL AMPS for MOTOR & HEATER	STAGE	MOTOR VOLTAGE	FULL LOAD AMPS for MOTOR ONLY	MOTOR H.P.	WT. (LBS)	LIST	
06176802	F1G7203	3	70-270	208/1	15.4	1	277	1	1/15	98	2644	
06065602	H1G7203			240/1	13.5						2728	
06062402	G1G7203			277/1	11.83						2644	
06069002	F3G7203			208/3	9.32						2728	
06177602	H3G7203			240/3	8.21						1856	
06176602	F1G7205	5	200-650	208/1	25.13	1	277	1.1	1/6	118	2729	
06179502	H1G7205			240/1	21.93						2778	
06061602	G1G7205			277/1	19.15						2729	
06064202	F3G7205			208/3	14.97						2778	
06179902	H3G7205			240/3	13.12						2729	
06065002	P3P7205	10	500-1200	480/3	7.11	1	277	.90	1/4	141	3266	
06065502	F3G7210			208/3	33.05						2.50	2840
05348702	H3G7210			240/3	25.75	1	480	1.7	2840			
06175802	P3P7210			480/3	13.72						3399	
06065102	F3G7210-2			208/3	33.05	2	277	2.50	3046			
05343902	H3G7210-2			240/3	25.75						1.7	3046
06063402	P3P7210-2			480/3	13.72	1	277	.90	3535			
06086002	F3G7215			208/3	46.93						2.50	3046
06088402	H3G7215			240/3	37.78	1	480	1.7	3046			
06060702	P3P7215			480/3	19.74						.90	3535
06069402	F3G7215-2	208/3	46.93	2	277	2.50	3199					
05344002	H3G7215-2	240/3	37.78					1.7	3199			
05345502	P3P7215-2	480/3	19.74	1	277	.90	3688					
06088302	F3G7220-2	208/3	63.81					3.1	3789			
05344102	H3G7220-2	20	750-1600	240/3	50.61	2	277	2.5	1/2	163	3789	
06064902	P3P7220-2			480/3	26.55						2.0	4277
05344202	F3G7223-2			208/3	74.84						2	277
06178802	H3G7223-2	240/3	59.63	2.2	4715							
05345602	P3P7225-2	25	1300-2000	480/3	34.37	2	480	2.2	278	4864		
05344302	H3G7230-2	240/3		78.47	8.0					6564		
06068802	P3P7230-2	480/3		42.38	2					480	4.0	2 MOTORS @ 1/2 H.P. EACH
05345702	P3P7235-2	480/3	48.39	4.0		7340						
05345802	P3P7240-2	40	1800-2800	480/3	56.71	2	480	4.4	2 MOTORS @ 3/4 H.P. EACH	319	8803	
05345902	P3P7245-2	45		2000-3600	480/3						62.72	8972
06180802	P3P7250-2	50		480/3	68.74						9560	

Note: Products listed in this section are custom built and subject to 100% cancellation/restock charges.

Product Dimensions

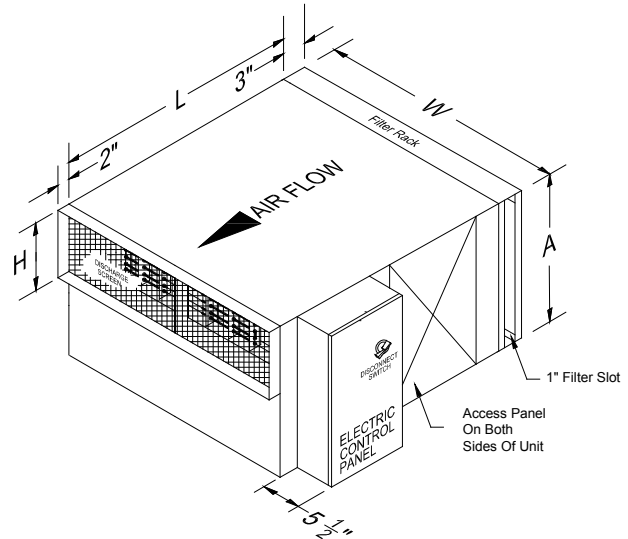
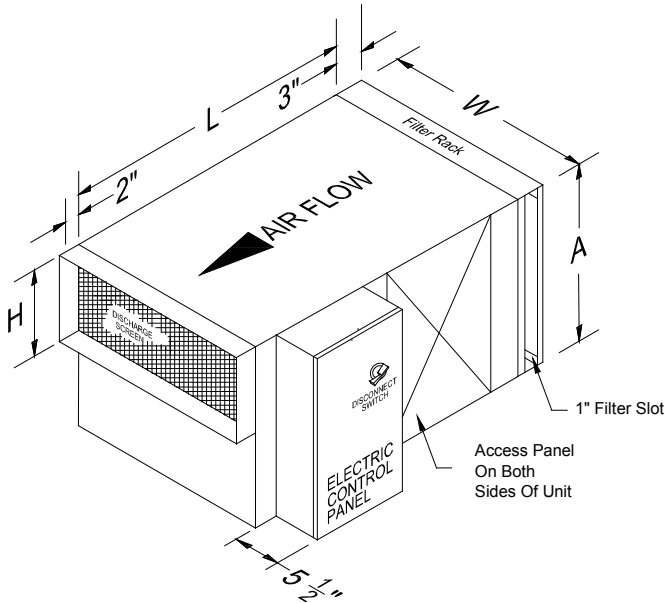

7200 SERIES	DIMENSIONS		DISCHARGE	
	A	L	W	H
3 KW	12"	32"	14"	8"
5 KW	14"	36"	18"	8"
10 & 15 KW	18"	36"	18"	10"
20 KW	18"	36"	22"	10"
23 & 25 KW	18"	36"	26"	10"

7200 SERIES	DIMENSIONS		
	A	W x H	L
25-30-35 KW	18"	44" x 10"	36"
40-45-50 KW	18"	52" x 10"	36"

Note: Control panel access standard as shown. For panel on opposite side access specify and order (Figure 5). * Control box depth depends on actual components. Consult factory for exact dimensions.

For 7200 Series accessories, see page 125.

7300 Series Plenum Heater

HOW TO DESIGNATE A MODEL:

F	3	E	73	15	2	T
Element Voltage F = 208V H = 240V G = 277V P = 480V	Phase 1 = Single Phase 3 = Three Phase	Motor Voltage G = 277 P = 480	Series Number	Element KW 3KW through 50KW See model chart for KW options.	Heater Stages Blank = One 2 = Two	Control System T = Unit Thermostat SSR = SSR Control Blank = None



*SSR proportional control maximum: 45 Amps

**SSRs require a 0-10vDC, 4-20mA, or 0-135Ω field supplied signal or an optional VT7225 thermostat

The 7300 Series LowBoy Plenum Heater is designed to fit jobs where the clear space between the ceiling and the floor above is as small as 11 3/4"

WARNING: This product can expose you to chemicals including nickel which is known to the State of California to cause cancer, and chromium, which is known to the State of California to cause birth defects and/or reproductive harm. For more information go to www.P65Warnings.ca.gov.

Product Specifications

- 20 gauge galvanized cabinet
- Variable speed motor, factory set at maximum
- Motor speed can be field adjusted to increase heat rise
- Acoustically insulated with 1" fiberglass
- Access panels on bottom of unit
- 24 Volt controls / Disconnect switch
- Air flow switch
- Terminal blocks
- 0" Clearance on sides, top, and bottom
- Single point connection
- Dust tight control enclosure
- Filter rack on inlet with throw away filter
- Inlet and outlet screens and duct connection
- Automatic primary limit control
- Optional wall thermostat, unit thermostat or SSR control which proportionally regulates heat output
- Made in U.S.A.

Standard Models

MFG CATALOG NUMBER	MFG MODEL NUMBER	KW	CFM RANGE	VOLTS/ PHASE	TOTAL AMPS for MOTOR & HEATER	STAGE	MOTOR VOLTAGE	FULL LOAD AMPS for MOTOR ONLY	MOTOR H.P.	WT. (LBS)	LIST						
06180702	F1G7305	5	170-950	208/1	26	1	277	2	1/4	163	2946						
06175402	H1G7305			240/1	22						3046						
06063002	G1G7305			277/1	20						2946						
06176402	F3G7305			208/3	15						3046						
05344502	H3G7305			240/3	14						2946						
05346002	P3P7305			480/3	8						3552						
06099602	F3G7310	10	170-950	208/3	32	1	277	2	1/4	163	3513						
06177302	H3G7310			240/3	26						3513						
06180602	P3P7310			480/3	14						3873						
06063602	F3G7310-2			208/3	32						3469						
05344602	H3G7310-2			240/3	26						3469						
05346102	P3P7310-2			480/3	14						3973						
05344802	H3G7312	12	270-1500	240/3	32	1	277	3	2 Motors @ 1/4 HP Each	219	4346						
05346202	P3P7312			480/3	17						4832						
06085902	F3G7312-2			208/3	41						4410						
05345002	H3G7312-2			240/3	32						4410						
05346302	P3P7312-2			480/3	17						4410						
05345202	H3G7315			240/3	39						4665						
06177702	P3P7315	15	270-1500	480/3	21	1	277	3	2 Motors @ 1/4 HP Each	219	5000						
06181002	F3G7315-2			208/3	49						4595						
06085102	H3G7315-2			240/3	39						4595						
05346402	P3P7315-2			480/3	21						5099						
05346502	P3P7318			480/3	25						1	480	2	2	2	219	5270
05346602	P3P7318-2			480/3													2

Note: Products listed in this section are custom built and subject to 100% cancellation/restock charges

Product Dimensions

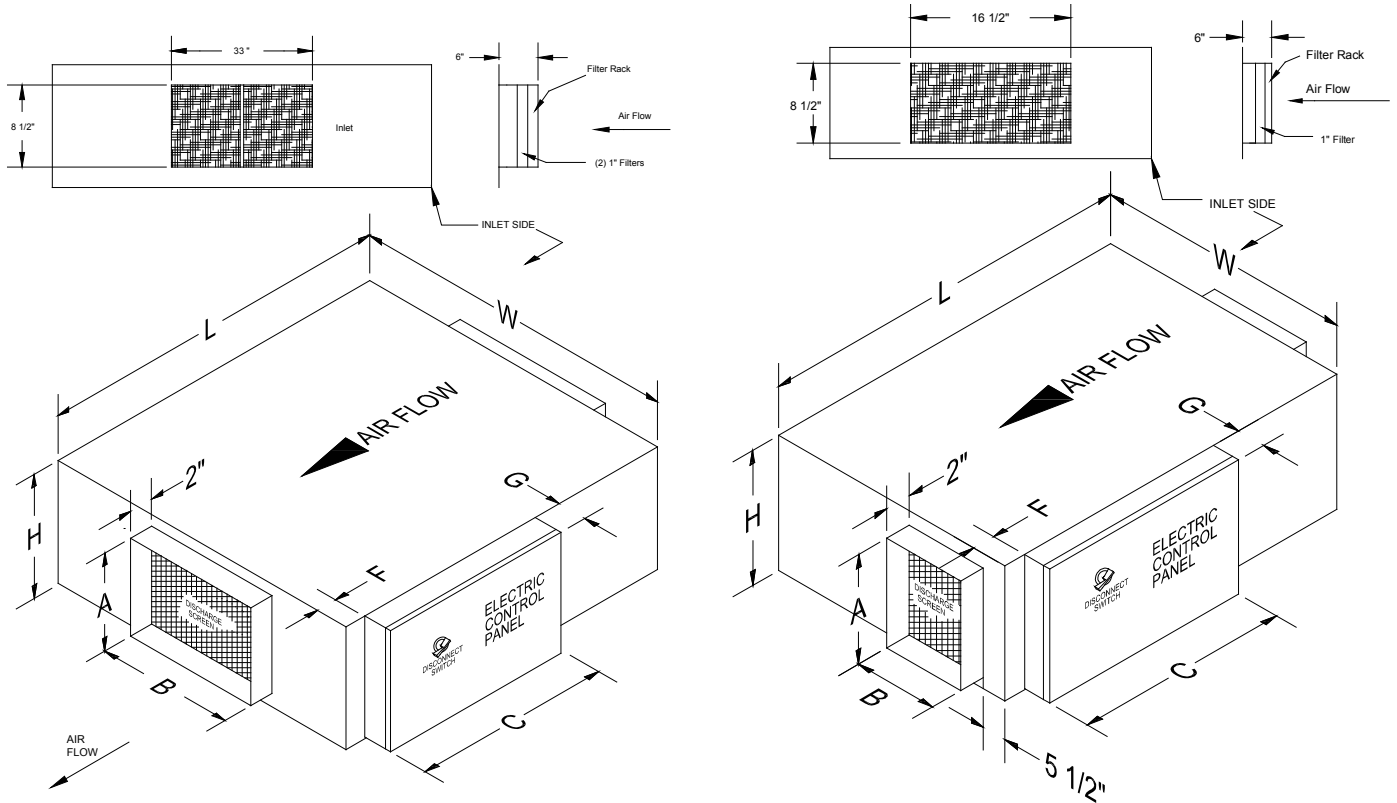

Note: Control panel access standard as shown. For panel on opposite side access specify and order.

WARNING: This product can expose you to chemicals including nickel which is known to the State of California to cause cancer, and chromium, which is known to the State of California to cause birth defects and/or reproductive harm. For more information go to www.P65Warnings.ca.gov.

DIMENSIONS								
7300 SERIES	C	F	G	H	L	W	DISCHARGE	
							A	B
5 & 10 KW	28, 75"	1"	6"	11.75"	45"	26"	8"	10"

Note: Dimension C and G will vary with accessories

DIMENSIONS								
7300 SERIES	C	F	G	H	L	W	DISCHARGE	
							A	B
12, 15, & 18 KW	28, 75"	2"	6"	11.75"	45"	43"	8"	20"

Note: Dimension C and G will vary with accessories

7200 & 7300 Series Accessories



LINE VOLTAGE DUCT MOUNTED THERMOSTATS						
CATALOG NUMBER	MODEL NUMBER	VOLTAGE RANGE	AMPS	STAGE	DESCRIPTION	LIST
05349402	TP504	120 - 277 VAC	22	Single Stage (SPDT)	Heat/Cool, -30 to 90°F, 3° - 12°F Fixed Differential	164
05349502	TP516	120 - 277 VAC	22	Single Stage (SPDT)	Heat/Cool, -30 to 90°F, 3° - 12°F Adjustable Differential	179

PD Series Packaged Duct Heater

Standard Features

- Galvanized Steel Element Rack - Always 1" shorter than duct height and ½" shorter than duct width to allow insertion clearance
- Galvanized Steel Compartment with ½" fiberglass
- Insulation & Hinged Cover
- Door Interlock Disconnect Switch
- Primary Automatic Reset Temp Limiting Control
- Load Carrying Secondary over Temperature
- Protective Device(s)
- Definite Purpose Magnetic Contactor(s)
- Differential Pressure Fan Inter-lock Switch
- Step Down Control Transformer / 24 Volt
- Permanently Attached Wiring Diagram on inside of Terminal Compartment Cover
- Made in U.S.A.

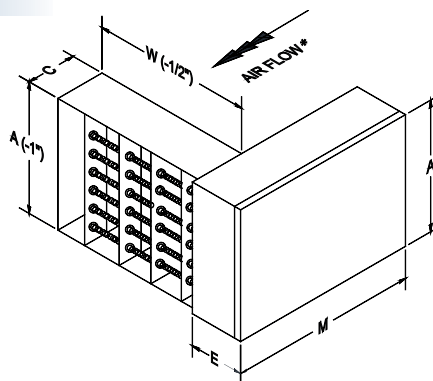

SPECIFY AIR FLOW (SHOWN)
(HL)* HORIZONTAL LEFT
(HR) HORIZONTAL RIGHT



Standard Models

MFG CATALOG NUMBER	MFG MODEL NUMBER	KW	POWER VOLTS/ PHASE	DUCT WIDTH W	DUCT HEIGHT A	DIMENSIONS			AMPS	CONTROL STEPS	WT. (LBS)	LIST	
						C	E	M					
06170002	PD5-128-1	5	240-1	12	8	4.75	6.5	27	20.9	1	22	1276	
06170102	PD10-1810-1	10		18	10	4.75	6.5	30	41.7	2	37	1713	
06170202	PD15-1812-1	15		18	12	4.75	6.5	40	62.5	2	33	2003	
06170302	PD20-2012-1	20		20	12	9.125	7.5	45	83.3	2	37	2513	
06170402	PD25-2016-1	25		20	16	9.125	7.5	41	104.2	3	56	4005	
06170502	7PD2-128-1	2	277-1	12	8	4.75	6.5	25	7.2	1	21	1276	
06170602	7PD3.5-128-1	3.5							12.6			1314	
06170702	7PD5-128-1	5							18.1			1685	
06170802	8PD5-128-3	5	208-3	12	8	4.75	6.5	26	13.9	1	22	1473	
06170902	8PD10-1810-3	10		18	10	4.75	6.5	21	27.8	1	27	1503	
06171002	8PD15-1812-3	15		18	12	9.125	6.5	27	41.7	1	32	1752	
06171102	8PD15-1812-2-3	15		18	12	9.125	6.5	29	41.7	2	34	1839	
06171202	8PD20-2012-3	20		20	12	9.125	6.5	48	55.6	2	39	2221	
06171302	8PD25-2016-3	25		20	16	9.125	6.5	38	69.5	2	58	2242	
06171402	8PD30-2416-3	30		24	16	9.125	7.5	34	83.4	2	65	3188	
06171502	8PD30-2416-3	30		24	16	9.125	7.5	45	83.4	3	60	3241	
06174302	8PD35-2416-3	35		24	16	9.125	7.5		97.3	3	65	3460	
06173202	8PD40-2416-3	40		24	16	9.125	7.5		111.2	3	75	4371	
06173302	8PD45-3016-3	45		30	16	9.125	7.5		125.1	3	80	4460	
06173402	8PD50-3016-3	50		30	16	9.125	7.5	50	139	3	85	4549	
06171602	PD5-128-3	5		240-3	12	8	4.75	6.5	27	12.1	1	21	1238
06171702	PD10-1812-3	10			18	10	4.75	6.5	23	24.1	1	26	1368
06171802	PD15-1812-1-3	15	18		12	4.75	6.5	28	36.2	1	30	1531	
06171902	PD15-1812-2-3	15	18		12	9.125	6.5	30	36.2	2	33	1566	
06172002	PD20-2012-3	19.9	20		12	9.125	6.5		47.9	2	39	2003	
06172102	PD25-2016-3	25	20		16	9.125	6.5	39	60.2	2	57	2242	
06172202	PD30-2416-2-3	30	24		16	4.75	6.5	35	72.3	2	57	2477	
06172302	PD30-2416-3-3	30	24		16	9.125	6.5	46	72.3	3	65	2586	
06173502	PD35-2416-3	35	24		16	9.125	7.5		84.3	3	65	2876	
06173602	PD40-2416-3	40	24		16	9.125	7.5		96.3	3	75	3314	
06173702	PD45-3016-3	45	30		16	9.125	7.5		108.4	3	80	4298	
06173802	PD50-3016-3	49.8	30		16	9.125	7.5	120	3	85	4479		
06172402	4PD5-128-3	5	480-3		12	8	4.75	6.5	25	6.1	1	21	1422
06172502	4PD10-1810-3	10			18	10	4.75	6.5	21	12.1	1	26	1503
06172602	4PD15-1812-3	15			18	12	4.75	6.5	19	18.1	1	30	1585
06172702	4PD15-1812-2-3	15			18	12	9.125	6.5	26	18.1	2	34	1821
06172802	4PD20-2012-3	20		20	12	9.125	6.5	24.1		2	39	1859	
06172902	4PD25-2016-3	25		20	16	9.125	6.5	22	30.1	2	58	1915	
06173002	4PD30-2416-2-3	30		24	16	4.75	6.5	18	36.2	2	65	1967	
06173102	4PD30-2416-3-3	30		24	16	9.125	6.5	26	36.2	3	65	2077	
06173902	4PD35-2416-3	35		24	16	9.125	6.5		42.2	3	65	2660	
06174002	4PD40-2416-3	39.9		24	16	9.125	6.5	38	48.1	3	75	3005	
06174202	4PD50-3016-3	50		30	16	9.125	6.5	38	60.2	3	85	3641	

MODEL	PAGE	MODEL	PAGE	MODEL	PAGE	MODEL	PAGE
150-TS	103	342-60-THSS-240V-AG	80	343-30-TH-240V	78	3900ACC	69
188 TASA	104	342-60-THSS-480V	79	343-30-TH-240V-AG	81	3900DS	69
18D-2-30CF (Enclosed)	95	342-60-THSS-480V-AG	80	343-30-TH-480V	78	3900DSC	69
18D-2-30CF (Open)	95	342-90-TH-208V	79	343-30-TH-480V-AG	81	3900REC	69
18D-2-80CF (Enclosed)	95	342-90-TH-208V-AG	80	343-30-THA-208V	82	3900RECC	69
198 TMC	103	342-90-TH-240V	79	343-30-THA-240V	82	3900T1	69
303EX16RW	34, 49	342-90-TH-240V-AG	80	343-30-THA-480V	82	3900T1C	69
303EX32RW	34, 49	342-90-TH-480V	79	343-30-THSS-208V	78	3900T2	69
303EX8RW	34, 49	342-90-TH-480V-AG	80	343-30-THSS-208V-AG	81	3900T2C	69
305EX16	39	342-90-THA-208V	83	343-30-THSS-240V	78	3900WW120	70
305EX32	39	342-90-THA-240V	83	343-30-THSS-240V-AG	81	3900WW28	70
305EX8	39	342-90-THA-480V	83	343-30-THSS-480V	78	3900WW36	70
30R1	34	342-90-THSS-208V	79	343-30-THSS-480V-AG	81	3900WW48	70
30R2	34	342-90-THSS-208V-AG	80	343-60-TH-208V	78	3900WW60	70
30R7	34	342-90-THSS-240V	79	343-60-TH-208V-AG	81	3900WW72	70
30R8	34	342-90-THSS-240V-AG	80	343-60-TH-240V	78	3900WW96	70
31939009	79	342-90-THSS-480V	79	343-60-TH-240V-AG	81	39BS120	70
31940009	79	342-90-THSS-480V-AG	80	343-60-TH-480V	78	39BS120C	70
31941009	79	342-A30-TH-208V	79	343-60-TH-480V-AG	81	39BS28	70
32T1	50	342-A30-TH-208V-AG	80	343-60-THA-208V	82	39BS28C	70
32T2	50	342-A30-TH-240V	79	343-60-THA-240V	82	39BS36	70
3310EX33R	49	342-A30-TH-240V-AG	80	343-60-THA-480V	82	39BS36C	70
3310EX33WR	49	342-A30-TH-480V	79	343-60-THSS-208V	78	39BS48	70
3320EX16	42, 43	342-A30-TH-480V-AG	80	343-60-THSS-208V-AG	81	39BS48C	70
3320EX33	42, 43	342-A30-THA-208V	83	343-60-THSS-240V	78	39BS60	70
3380EX33	34	342-A30-THA-240V	83	343-60-THSS-240V-AG	81	39BS60C	70
342-30-TH-208V	79	342-A30-THA-480V	83	343-60-THSS-480V	78	39BS72	70
342-30-TH-208V-AG	80	342-A30-THSS-208V	79	343-60-THSS-480V-AG	80	39BS72C	70
342-30-TH-240V	79	342-A30-THSS-208V-AG	80	343-90-TH-208V	78	39BS96	70
342-30-TH-240V-AG	80	342-A30-THSS-240V	79	343-90-TH-208V-AG	81	39BS96C	70
342-30-TH-480V	79	342-A30-THSS-240V-AG	80	343-90-TH-240V	78	4300EX16	51
342-30-TH-480V-AG	80	342-A30-THSS-480V	79	343-90-TH-240V-AG	81	4300EX16W	50, 51
342-30-THA-208V	83	342-A30-THSS-480V-AG	80	343-90-TH-480V	78	4300EX32	51
342-30-THA-240V	83	342-A60-TH-208V	79	343-90-TH-480V-AG	81	4300EX32W	50, 51
342-30-THA-480V	83	342-A60-TH-208V-AG	80	343-90-THA-208V	82	4300EX8	50
342-30-THSS-208V	79	342-A60-TH-240V	79	343-90-THA-240V	82	4300EX8W	50, 51
342-30-THSS-208V-AG	80	342-A60-TH-240V-AG	80	343-90-THA-480V	82	4300P	51
342-30-THSS-240V	79	342-A60-TH-480V	79	343-90-THSS-208V	78	4300PB	39
342-30-THSS-240V-AG	80	342-A60-TH-480V-AG	80	343-90-THSS-208V-AG	81	4300PW	50, 51
342-30-THSS-480V	79	342-A60-THA-208V	83	343-90-THSS-240V	78	43T	50, 51
342-30-THSS-480V-AG	80	342-A60-THA-240V	83	343-90-THSS-240V-AG	81	43T2	51
342-60-TH-208V	79	342-A60-THA-480V	83	343-90-THSS-480V	78	4400EX16	39
342-60-TH-208V-AG	80	342-A60-THSS-208V	79	343-90-THSS-480V-AG	81	4400EX32	39
342-60-TH-240V	79	342-A60-THSS-208V-AG	80	3450EX16	46	4400EX8	39
342-60-TH-240V-AG	80	342-A60-THSS-240V	79	3450EX34	46	462-30-TH-480V	79
342-60-TH-480V	79	342-A60-THSS-240V-AG	80	3450EX8	46	462-30-TH-480V-AG	80
342-60-TH-480V-AG	80	342-A60-THSS-480V	79	3900-CS	69	462-30-THA-480V	82
342-60-THA-208V	83	342-A60-THSS-480V-AG	80	3900-CSC	69	462-30-THSS-480V	79
342-60-THA-240V	83	3420EX16	46	3900-ICS	69	462-30-THSS-480V-AG	80
342-60-THA-480V	83	3420EX34	46	3900-ICSC	69	462-60-TH-480V	79
342-60-THSS-208V	79	3420EX8	46	3900-OCS	69	462-60-TH-480V-AG	80
342-60-THSS-208V-AG	80	343-30-TH-208V	78	3900-OCSC	69	462-60-THA-480V	82
342-60-THSS-240V	79	343-30-TH-208V-AG	81	3900AC	69	462-60-THSS-480V	79

Product Index Listing

MODEL	PAGE	MODEL	PAGE	MODEL	PAGE	MODEL	PAGE
462-60-THSS-480V-AG	80	59129107	85	64337-038	94	8528	29
462-90-TH-480V	79	59129108	85	64337-039	94	8529	29
462-90-TH-480V-AG	80	59129109	85	64337-040	94	8530	29
462-90-THA-480V	82	61-01729-00	115	64337-041	94	8532	29
462-90-THSS-480V	79	61-01729-20	115	64337-049	94	8533	29
462-90-THSS-480V-AG	80	61-01729-21	115	64337-050	94	8534	29
462-A30-TH-480V	79	61-01729-22	115	64337-051	94	8535	29
462-A30-TH-480V-AG	80	61-01729-27	115	64337-052	94	8536	29
462-A30-THA-480V	82	61-01730-00	115	64337-053	94	8537	29
462-A30-THSS-480V	79	61-01730-003	115	64337-054	94	8538	29
462-A30-THSS-480V-AG	80	630-05129	94	671-3454	94	8539	29
462-A60-TH-480V	79	630-16209	94	671-3492	94	9100EC	55
462-A60-TH-480V-AG	80	630-16249	94	671-3784	94	9100IC	55
462-A60-THA-480V	82	630-16279	94	671-3785	94	9100OC	55
462-A60-THSS-480V	79	630-16489	94	671-3786	94	9100SP	55
462-A60-THSS-480V-AG	80	630-25209	94	671-5018	94	91BS012	55
463-30-TH-480V	78	630-25249	94	671-5056	94	91BS024	55
463-30-TH-480V-AG	81	630-25279	94	671-5057	94	91BS036	55
463-30-THA-480V	82	630-25489	94	671-5058	94	91BS048	55
463-30-THSS-480V	78	630-36489	94	671-5059	94	91BS060	55
463-30-THSS-480V-AG	81	630-38579	94	671-5060	94	91BS072	55
463-60-TH-480V	78	631-16249	94	671-5061	94	91BS084	55
463-60-TH-480V-AG	81	631-25489	94	7PD2-128-1	124	91BS096	55
463-60-THA-480V	82	631-25609	94	7PD3.5-128-1	124	91BS108	55
463-60-THSS-480V	78	631-38579	94	7PD5-128-1	124	91BS120	55
463-60-THSS-480V-AG	81	632-1620	85, 93, 94	8PD10-1810-3	124	9128	55
463-90-TH-480V	78	632-1624	79, 88	8PD15-1812-2-3	124	9136	55
463-90-TH-480V-AG	81	632-2548	84, 85, 94	8PD15-1812-3	124	9148	55
463-90-THA-480V	82	6333D052033B30D0F	25	8PD20-2012-3	124	9160	55
463-90-THSS-480V	78	6333D052433B30D0F	25	8PD25-2016-3	124	9172	55
463-90-THSS-480V-AG	81	6333D053834B30D0F1	25	8PD30-2416-2-3	124	9184	55
483 TM	104	6333D054134B30D0F1	25	8PD30-2416-3	124	9196	55
48T2	52	6333D054833B30D0F	25	8PD35-2416-3	124	91108	55
4PD10-1810-3	124	6333D103834B30D0F1	25	8PD40-2416-3	124	91120	55
4PD15-1812-2-3	124	6333D104134B30D0F1	25	8PD45-3016-3	124	9300EC	55
4PD15-1812-3	124	6346D102433B30D0F	25	8PD5-128-3	124	9300IC	55
4PD20-2012-3	124	6346D104833B30D0F	25	8PD50-3016-3	124	9300OC	55
4PD25-2016-3	124	64337-022	94	8510	29	9300SP	55
4PD30-2416-2-3	124	64337-023	94	8512	29	93BS012	57
4PD30-2416-3-3	124	64337-024	94	8513	29	93BS024	57
4PD35-2416-3	124	64337-025	94	8514	29	93BS036	57
4PD40-2416-3	124	64337-026	94	8515	29	93BS048	57
4PD5-128-3	124	64337-027	94	8516	29	93BS060	57
4PD50-3016-3	124	64337-028	94	8517	29	93BS072	57
59111101	85	64337-029	94	8518	29	93BS084	57
59111102	85	64337-030	94	8519	29	93BS096	57
59111103	85	64337-031	94	8520	29	93BS108	57
59129101	85	64337-032	94	8522	29	93BS120	57
59129102	85	64337-033	94	8523	29	9328	55
59129103	85	64337-034	94	8524	29	9336	55
59129104	85	64337-035	94	8525	29	9348	55
59129105	85	64337-036	94	8526	29	9360	55
59129106	85	64337-037	94	8527	29	9372	55

MODEL	PAGE	MODEL	PAGE	MODEL	PAGE	MODEL	PAGE
9384	55	B51100	18	BS9948-03	66	CP807	37
9396	55	B5150	15	BS9960-01	66	CS	73
93108	55	B5175	18	BS9960-02	66	CS 12	54
93120	55	BBS024A	73	BS9960-03	66	CS 6	54
A1600	21	BBS024AW	73	BS9972-01	66	CS99-01-ATR 208V 22A	66
A1601	21	BBS024C	73	BS9972-02	66	CS99-01-ATR 240V 22A	66
A5105	15	BBS028A	73	BS9972-03	66	CS99-01-ATR 277V 18A	66
A51100	18	BBS028AW	73	BS9984-01	66	CS99-01-LVTR 208V 30A	66
A5120	15	BBS028C	73	BS9984-02	66	CS99-01-LVTR 240V 30A	66
A5150	15	BBS036A	73	BS9984-03	66	CS99-01-LVTR 277V 30A	66
A5175	18	BBS036AW	73	BS9996-01	66	CS99-01-LVTR 480V 15A	66
A5520/UHB	10	BBS036C	73	BS9996-02	66	CS99-01-PC-208V 1PH	66
AD5120	15	BBS040A	73	BS9996-03	66	CS99-01-PC-240V 1PH	66
AD5150	15	BBS040AW	73	C1-TD	107	CS99-01-PC-277V 1PH	66
AD5175	15	BBS040C	73	C1-TDP	108	CS99-01-PC-480V 1PH	66
AET9DWTS	109	BBS048A	73	CF35-C	108	CS99-02-ATR 208V 22A	66
AET9SWTS	109	BBS048AW	73	CF36	108	CS99-02-ATR 240V 22A	66
AGS1620	85	BBS048C	73	CF47-C	108	CS99-02-ATR 277V 18A	66
AGS1624	85	BBS060A	73	CF48	84	CS99-02-LVTR 208V 30A	66
AGS1627	85	BBS060AW	73	CF59-C	84	CS99-02-LVTR 240V 30A	66
AGS1648	85	BBS060C	73	CF60	84	CS99-02-LVTR 277V 30A	66
AGS2520	85	BBS072A	73	CFHD36	84	CS99-02-LVTR 480V 15A	66
AGS2524	85	BBS072AW	73	CFHD48	84	CS99-02-PC-208V 1PH	66
AGS2548	85	BBS072C	73	CFHD60	84	CS99-02-PC-240V 1PH	66
AGS3648	85	BBS084A	73	CHWG-222	95	CS99-02-PC-277V 1PH	66
APS-3C	95	BBS084AW	73	CHWG-223	110	CS99-02-PC-480V 1PH	66
ASHDB ECL	61	BBS084C	73	CHWG-342	110	CS99-03-ATR 208V 22A	66
ASHDB ECR	61	BBS096A	73	CHWG-343	110	CS99-03-ATR 240V 22A	66
ASHDB IC	61	BBS096AW	73	CHWG-462	37	CS99-03-ATR 277V 18A	66
ASHDB OC	61	BBS096C	73	CHWG-463	37	CS99-03-LVTR 208V 30A	66
ASHDB SP	61	BBS120A	73	CIT-1	37	CS99-03-LVTR 240V 30A	66
ASHDB WT	61	BBS120AW	73	CKT0121	37	CS99-03-LVTR 277V 30A	66
ASHDB-10	61	BBS120C	73	CKT121	37	CS99-03-LVTR 480V 15A	66
ASHDB-2	61	BDR115	73	CKTD110	37	CS99-03-PC-208V 1PH	66
ASHDB-3	61	BDR115B	73	CP122	37	CS99-03-PC-208V 3PH	66
ASHDB-4	61	BDR115W	73	CP122i	37	CS99-03-PC-240V 1PH	66
ASHDB-5	61	BOX 3310	42, 43, 42	CP123	37	CS99-03-PC-240V 3PH	66
ASHDB-6	61	BOX 3420	46	CP123i	37	CS99-03-PC-277V 1PH	66
ASHDB-7	61	BOX 3450	46	CP125	37	CS99-03-PC-480V 1PH	66
ASHDB-8	61	BS99108-01	9	CP125i	37	CS99-03-PC-480V 3PH	66
ASHDB-8/20-1000BS	61	BS99108-02	9	CP127	37	CSB	73
ASHDB-8/20-100BS	61	BS99108-03	107	CP127i	37	CSW	110
ASHDB-8/20-200BS	61	BS99120-01	108	CP2202i	37	CTW155B	73
ASHDB-8/20-300BS	61	BS99120-02	107	CP2203i	37	CTW155C	110
ASHDB-8/20-400BS	61	BS99120-03	108	CP2205i	37	CV10012X	38
ASHDB-8/20-500BS	61	BS9928-01	66	CP2207i	37	CV10022Xi	38
ASHDB-8/20-600BS	61	BS9928-02	66	CP702	37	CV10027X	38
ASHDB-8/20-700BS	61	BS9928-03	66	CP703	37	CV100X	38
ASHDB-8/20-800BS	61	BS9936-01	66	CP705	37	CV100Xi	38
ASHDB-8/20-900BS	61	BS9936-02	66	CP707	37	CV100YX	38
ASHDB-9	61	BS9936-03	66	CP802	37	CV11012X	38
ATR	55	BS9948-01	66	CP803	37	CV11022Xi	38
B5105	15	BS9948-02	66	CP805	37	CV11027X	38

Product Index Listing

130

INDEX

MODEL	PAGE	MODEL	PAGE	MODEL	PAGE	MODEL	PAGE
CV110X	38	DBF-7/DBT-7	59	E2905-028SW	71	E3703-024B	68
CV110Xi	38	DBF-8/DBT-8	59	E2906-036C	72	E3705-028	68
CV110YX	38	DBF-9/DBT-9	59	E2906-036S	71	E3705-028B	68
CV12512X	38	DBF/DBT ECL	59	E2906-036SW	71	E3706-036	68
CV12522Xi	38	DBF/DBT ECR	59	E2907-040C	71	E3706-036B	68
CV12527X	38	DBF/DBT IC	59	E2907-040S	71	E3707-040	68
CV125X	38	DBF/DBT IECL	59	E2907-040SW	71	E3707-040B	68
CV125Xi	38	DBF/DBT IECR	59	E2910-048C	71	E3710-048	68
CV125YX	38	DBF/DBT IF	59	E2910-048S	71	E3710-048B	68
CV4512X	38	DBF/DBT MF	59	E2910-048SW	71	E3712-060	68
CV4522Xi	38	DBF/DBT OC	59	E2912-060C	71	E3712-060B	68
CV4527X	38	DBF/DBT SP	59	E2912-060S	71	E3715-072	68
CV45X	38	DBF/DBT WT	59	E2912-060SW	71	E3715-072B	68
CV45Xi	38	DBF/DBT-1000BS	59	E2915-072C	71	E3904-28	67
CV45YX	38	DBF/DBT-100BS	59	E2915-072S	71	E3904-28C	67
CV6012X	38	DBF/DBT-200BS	59	E2915-072SW	71	E3906-36	67
CV6022Xi	38	DBF/DBT-300BS	59	E3035DWBW	34	E3906-36C	67
CV6027X	38	DBF/DBT-400BS	59	E3038DWBW	34	E3910-48	67
CV60X	38	DBF/DBT-500BS	59	E3055T2DWB	39	E3910-48C	67
CV60Xi	38	DBF/DBT-600BS	59	E3055TDWB	39	E3912-60	67
CV60YX	38	DBF/DBT-700BS	59	E3058T2DWB	39	E3912-60C	67
CV7512X	38	DBF/DBT-800BS	59	E3058TDWB	39	E3915-60P	104
CV7522Xi	38	DBF/DBT-900BS	59	E3210RPW	50	E3915-72	67
CV7527X	38	DC-33	25	E3210TRPW	50	E3915-72C	67
CV75X	38	DC-46	25	E3215RPW	50	E4310RP	51
CV75Xi	38	DC-66	25	E3215TRPW	50	E4310RPW	51
CV75YX	38	DC-79	25	E3275RPW	50	E4310TRP	51
CV9012X	38	DC-SK-1	99	E3275TRPW	50	E4310TRPW	51
CV9022Xi	38	DCS-MT303	22, 23, 111	E3312RP	47	E4315RP	51
CV9027X	38	DCS1003	12	E3312RPW	47	E4315RPW	51
CV90X	38	DCS1003/5100	17	E3312T2RP	47	E4315TRP	51
CV90Xi	38	DCS202/5100	17	E3312T2RPW	47	E4315TRPW	51
CV90YX	38	DCS303	12	E3312T2SRP	49	E4375RP	51
CVB42X	38	DCS403	12	E3312T2SRPW	49	E4375RPW	51
CVB60X	38	DCS403/5100	17	E3312TRP	47	E4375TRP	51
CVB84X	38	DCS603/5100	17	E3312TRPW	47	E4375TRPW	51
CVCBX	38	DCS803	12	E3312TSRP	49	E4410TRP	39
CVSP	38	DR115	73	E3312TSRPW	49	E4415TRP	39
D1600	21	DR115B	73	E3313RP	47	E4475TRP	39
D1602	21	DR115W	73	E3313RPW	47	E4810RPW	52
D1603	21	DS	73	E3313T2RP	47	E4810TRPW	52
D1610	21	DS5105	15	E3313T2RPW	47	E4815RPW	52
D1612	21	DS51100	18	E3313T2SRP	49	E4815TRPW	52
D1613	21	DS5120	15	E3313T2SRPW	49	E4875RPW	52
D2022H10BA	109	DS5150	15	E3313TRP	47	E4875TRPW	52
D2022H10BB	109	DS5175	18	E3313TRPW	47	E8801050	31
D2025H10DA	109	DSB	73	E3313TSRP	49	E8802075	31
DBF-10/DBT-10	59	DSW	73	E3313TSRPW	49	E8803100	31
DBF-2/DBT-2	59	E2903-024C	72	E3321TD-RP	42	E8804125	31
DBF-3/DBT-3	59	E2903-024S	71	E3322TD-RP	42	E8805150	31
DBF-4/DBT-4	59	E2903-024SW	71	E3323TD-RP	42	E8806200	31
DBF-5/DBT-5	59	E2905-028C	72	E3383D-RP	34	EPETD8D	9, 109
DBF-6/DBT-6	59	E2905-028S	71	E3703-024	68	EPETD8S	6, 9, 109

MODEL	PAGE	MODEL	PAGE	MODEL	PAGE	MODEL	PAGE
EPETP8D	9, 109	F2906-036S	71	F3317T2SRP	49	F3712-060B	68
EPETP8S	9, 109	F2906-036SW	31	F3317T2SRPW	49	F3715-072	68
ET9D4TS	109	F2907-040C	31	F3317TRP	47	F3715-072B	68
ET9DTS	109	F2907-040S	31	F3317TRPW	47	F3717-084	68
ET9DWTS	109	F2907-040SW	9, 110	F3317TSRP	49	F3717-084B	68
ET9MTS	109	F2910-048C	6, 9, 110	F3317TSRPW	49	F3720-096	68
ET9S4TS	109	F2910-048S	9, 109	F3326TD-RP	42	F3720-096B	68
ET9SRTS	17, 109	F2910-048SW	71	F3327TD-RP	42	F3725-120	68
ET9STS	109	F2912-060C	71	F3346	40	F3725-120B	67
ET9SWTS	109	F2912-060S	71	F3346-BMS	40	F3904-28	67
ETD9M4TS	109	F2912-060SW	71	F3346-BMS-W	41	F3904-28C	67
ETD9MTS	109	F2915-072C	71	F3346-BMSTB	40	F3906-36	67
ETD9STS	109	F2915-072S	71	F3346-BMSTB	40	F3906-36C	67
F1F2605CA1	21	F2915-072SW	71	F3346-W	34	F3910-48	67
F1F2607CA1	21	F2917-084C	71	F3346T	40	F3910-48C	67
F1F2610CA1	21	F2917-084S	71	F3346T-BMS	40	F3912-60	67
F1F5103N	17	F2917-084SW	71	F3346T-BMS-W	41	F3912-60C	67
F1F5105N	17	F2920-096C	71	F3346T-BMSTB	40	F3915-72	67
F1F5503T	11	F2920-096S	71	F3346T-BMSTB	40	F3915-72C	67
F1F5505T	11	F2920-096SW	71	F3346T-W	41	F3920-96	67
F1F5507T	11	F2925-120C	71	F3386D-RP	34	F3920-96C	67
F1F5510T	11	F2925-120S	71	F3387D-RP	44	F3F2605CA1	21
F1F5515T	11	F2925-120SW	71	F3422T	44	F3F2607CA1	21
F1FUH03003	13	F2F5103N	17	F3423T	44	F3F2610CA1	21
F1FUH05003	13	F2F5105N	17	F3424T	44	F3F2615CA1	21
F1FUH07CA1	13	F2F5107CA1L	17	F3425T	46	F3F2625CA1	21
F1FUH10CA1	13	F2F5110CA1L	17	F3452SD	44	F3F2630CA1	21
F1FUH12C03	13	F2FUH05C03	13	F3452T	46	F3F2640CA1	21
F1FUH15C03	13	F2FUH10C03	13	F3453SD	44	F3F2650CA1	21
F1FUH20CA1	13	F2FUHE05C03T	15	F3453T	46	F3F5115CA1L	16, 17
F1FUH25CA1	13	F2FUHE05C03T	54	F3454SD	44	F3F5125CA1L	16, 17
F1FUHE03003T	15	F2FUHE10C03T	15	F3454T	46	F3F5130CA1L	16, 17
F1FUHE03003T	54	F2FUHE10C03T	54	F3455SD	44	F3F5140CA1L	16, 17
F1FUHE05003T	15	F30522T2DWB	39	F3455T	36	F3F5150CA1L	16, 17
F1FUHE05003T	54	F30522TDWB	39	F3472A1	36	F3F5160CA1	19
F1FUHE07CA1T	15	F3052T2DWB	39	F3473A1	36	F3F5170CA1	19
F1FUHE07CA1T	54	F3052TDWB	39	F3474A1	36	F3F5503T	11
F1FUHE10CA1T	15	F3220RPW	50	F3475A1	35	F3F5505T	11
F1FUHE10CA1T	54	F3220T2RPW	50	F3482A1	35	F3F5507T	11
F1FUHE12C03T	15	F3316RP	47	F3483A1	35	F3F5510T	11
F1FUHE12C03T	54	F3316RPW	47	F3484A1	35	F3F5515T	11
F1FUHE15C03T	15	F3316T2RP	47	F3485A1	68	F3F5520T	11
F1FUHE15C03T	54	F3316T2RPW	47	F3703-024	68	F3F5525T	11
F1G7203	121	F3316T2SRP	49	F3703-024B	68	F3F5530T	11
F1G7205	121	F3316T2SRPW	49	F3705-028	68	F3FUH03C03	13
F1G7305	121	F3316TRP	47	F3705-028B	68	F3FUH07C03	13
F2903-024C	71	F3316TRPW	47	F3706-036	68	F3FUH12C03	13
F2903-024S	71	F3316TSRP	49	F3706-036B	68	F3FUH15C03	13
F2903-024SW	71	F3316TSRPW	49	F3707-040	68	F3FUH20CA1	13
F2905-028C	71	F3317RP	47	F3707-040B	68	F3FUH25CA1	13
F2905-028S	71	F3317RPW	47	F3710-048	68	F3FUH30CA1	13
F2905-028SW	71	F3317T2RP	47	F3710-048B	68	F3FUHE03C03T	15
F2906-036C	71	F3317T2RPW	47	F3712-060	68	F3FUHE03C03T	54

Product Index Listing

MODEL	PAGE	MODEL	PAGE	MODEL	PAGE	MODEL	PAGE
F3FUHE07C03T	15	F9936-03-200	64	FEP-1627-1RA	8	FES-1520-3A	102
F3FUHE07C03T	54	F9936-03-300	64	FEP-1648-1RA	8	FES-1524-1A	102
F3FUHE12C03T	15	F9948-01-150	63	FEP-1648-3RA	9	FES-1524-3E	102
F3FUHE12C03T	54	F9948-01-200	63	FEP-1657-1RA	8	FES-1548-3E	102
F3FUHE15C03T	15	F9948-02-200	63	FEP-1712-1RA	8	FES-1560-3A	102
F3FUHE15C03T	54	F9948-02-300	64	FEP-1720-1RA	8	FES-3048-3A	102
F3G7203	121	F9948-03-200	64	FEP-1720-3RA	9	FES-3060-3A	102
F3G7205	121	F9948-03-300	64	FEP-1724-1RA	8	FES-4548-3	102
F3G7210	121	F9960-01-150	63	FEP-1724-3RA	9	FES-6057-3	102
F3G7210-2	121	F9960-01-200	63	FEP-1727-1RA	8	FFH-512A	93
F3G7215	121	F9960-02-200	63	FEP-1748-1RA	8	FFH-912B	93
F3G7215-2	121	F9960-02-300	64	FEP-1748-3RA	9	FH15	107
F3G7220-2	121	F9960-03-200	64	FEP-1812-1RA	8	FH1T	107
F3G7223-2	121	F9960-03-300	64	FEP-1820-1RA	8	FPC2110	96
F3G7305	122	F9972-01-150	63	FEP-1820-3RA	9	FPC2120	96
F4320RP	51	F9972-01-200	63	FEP-1824-1RA	8	FPC2140	96
F4320RPW	51	F9972-02-200	63	FEP-1824-3RA	9	FPC2160	96
F4320T2RP	51	F9972-02-300	64	FEP-1827-1RA	8	FPC2210	96
F4320T2RPW	51	F9972-03-200	64	FEP-1848-1RA	8	FPC2220	96
F4320TRP	51	F9972-03-300	64	FEP-1848-3RA	9	FPC2240	96
F4320TRPW	51	F9984-01-150	63	FEP-3420-1RA	8	FPC2260	96
F4420T2RP	39	F9984-01-200	63	FEP-3420-3RA	9	FPC4110	96
F4420TRP	39	F9984-02-200	63	FEP-3424-1RA	8	FPC4120	96
F4820RPW	52	F9984-02-300	64	FEP-3424-3RA	9	FPC4140	96
F4820T2RPW	52	F9984-03-200	64	FEP-3427-1RA	8	FPC4160	96
F4820TRPW	52	F9984-03-300	64	FEP-3448-1RA	8	FPC4210	96
F8801050	31	F9996-01-150	63	FEP-3448-3RA	9	FPC4220	96
F8802075	31	F9996-01-200	63	FEP-3457-1RA	8	FPC4240	96
F8803100	31	F9996-02-200	63	FEP-3620-1RA	8	FPC4260	96
F8804125	31	F9996-02-300	64	FEP-3620-3RA	9	FPC7110	96
F8805150	31	F9996-03-200	64	FEP-3624-1RA	8	FPC7120	96
F8806200	31	F9996-03-300	64	FEP-3624-3RA	9	FPC7140	96
F99108-01-150	63	FAM33	25	FEP-3627-1RA	8	FPC7160	96
F99108-01-200	63	FAM46	25	FEP-3648-1RA	8	FPC7210	96
F99108-02-200	63	FAM66	25	FEP-3648-3RA	9	FPC7220	96
F99108-02-300	64	FAM79	25	FEP-3657-1RA	8	FPC7240	96
F99108-03-200	64	FEC-30-120	96	FEP-3820-1RA	8	FPC7260	96
F99108-03-300	64	FEC-30-240	96	FEP-3820-3RA	9	FPC8110	96
F99120-01-150	64	FEC-60-120	96	FEP-3824-1RA	8	FPC8120	96
F99120-01-200	63	FEC-60-240	96	FEP-3824-3RA	9	FPC8140	96
F99120-02-200	63	FEP-0812-1RA	8	FEP-38271-RA	8	FPC8160	96
F99120-02-300	64	FEP-0820-1RA	8	FEP-3848-1RA	8	FPC8210	96
F99120-03-200	64	FEP-0820-3RA	9	FEP-7620-1RA	8	FPC8220	96
F99120-03-300	64	FEP-0824-1RA	8	FEP-7620-3RA	9	FPC8240	96
F9928-01-129	63	FEP-0824-3RA	9	FEP-7624-1RA	8	FPC8260	96
F9928-01-86	63	FEP-0827-1RA	8	FEP-7624-3RA	9	FS5101	17, 19
F9928-02-172	63	FEP-0848-1RA	8	FEP-7627-1RA	8	FS5102	17, 19
F9928-03-129	64	FEP-0848-3RA	9	FEP-7648-1RA	8	FSA-14-31WMB	88
F9928-03-172	64	FEP-1612-1RA	8	FEP-7648-3RA	9	FSA-1412-1	88
F9936-01-150	63	FEP-1620-1RA	8	FEP-7657-1RA	8	FSA-1420-1	88
F9936-01-200	63	FEP-1620-3RA	9	FEP3848-3RA	9	FSA-1424-1	88
F9936-02-200	63	FEP-1624-1RA	8	FES-0924-1C	102	FSA-1427-1	88
F9936-02-300	64	FEP-1624-3RA	9	FES-1024-1CA	102	FSA-1448-1	88

MODEL	PAGE	MODEL	PAGE	MODEL	PAGE	MODEL	PAGE
FSA-1457-1	88	FSS-4320-3	86	G2907-040C	72	G3316RP	47
FSA-3120-1	88	FSS-4324-3	86	G2907-040S	71	G3316RPW	47
FSA-3124-1	88	FSS-4327-1	86	G2907-040SW	71	G3316T2RP	47
FSA-3127-1	88	FSS-4348-3	86	G2907-048C	72	G3316T2RPW	47
FSA-3148-1	88	FSS-4357-3	86	G2907-048S	71	G3316TRP	47
FSA-3418-1	88	FSS-6520-3	90	G2907-048SW	71	G3316TRPW	47
FSA-4320-3	88	FSS-6524-3	90	G2909-060C	72	G3317RP	47
FSA-4324-3	88	FSS-6527-1	90	G2909-060S	71	G3317RPW	47
FSA-4327-1	88	FSS-6548-3	90	G2909-060SW	71	G3317T2RP	47
FSA-4348-3	88	FSS-6557-3	90	G2910-048C	72	G3317T2RPW	47
FSA-4357-3	88	FSS-9520-3	86	G2910-048S	71	G3317TRP	47
FSA-6520-3	92	FSS-9524-3	86	G2910-048SW	71	G3317TRPW	47
FSA-6524-3	92	FSS-9527-1	86	G2911-072C	72	G3323TD-RP	42
FSA-6527-1	92	FSS-9548-3	86	G2911-072S	71	G3324TD-RP	42
FSA-6548-3	92	FSS-9557-3	86	G2911-072SW	71	G3325TD-RP	42
FSA-6557-3	92	FSS95TMK	86	G2912-060C	72	G3326TD-RP	42
FSA-9520-3	88	FSW5111	17	G2912-060S	71	G3327TD-RP	42
FSA-9524-3	88	FSW5112	17, 19, 21	G2912-060SW	71	G3346	40
FSA-9527-1	88	G1G2605CA1	21	G2913-084C	72	G3346-BMS	40
FSA-9548-3	88	G1G2607CA1	21	G2913-084S	71	G3346-BMS-W	41
FSA-9557-3	88	G1G2610CA1	21	G2913-084SW	71	G3346-BMSTB	40
FSP-1412-1C	99	G1G5103N	16, 17	G2915-072C	72	G3346-BMSTB	40
FSP-3120-1	99	G1G5105N	16, 17	G2915-072S	71	G3346-W	41
FSP-3124-1	99	G1G5107CA1L	16, 17	G2915-072SW	71	G3346T	40
FSP-3127-1	99	G1G5110CA1N	16, 17	G2915-096C	72	G3346T-BMS	40
FSP-3148-1	99	G1G5503T	11	G2915-096S	71	G3346T-BMS-W	41
FSP-3157-1	99	G1G5505T	11	G2915-096SW	71	G3346T-BMSTB	40
FSP-4320-3	99	G1G5507T	11	G2917-084C	72	G3346T-BMSTB	40
FSP-4324-3	99	G1G5510T	11	G2917-084S	71	G3346T-W	41
FSP-4327-1	99	G1G7203	121	G2917-084SW	71	G3348	40
FSP-4348-3	99	G1G7205	121	G2918-120C	72	G3348-BMS	40
FSP-4357-3	99	G1G7305	121	G2918-120S	71	G3348-BMS-W	41
FSP-6520-3	103	G1GUH03003	13	G2918-120SW	71	G3348-BMSTB	40
FSP-6524-3	103	G1GUH05003	13	G2920-096C	72	G3348-BMSTB	40
FSP-6527-1	103	G1GUH07CA1	13	G2920-096S	71	G3348-W	41
FSP-6548-3	103	G1GUH10CA1	13	G2920-096SW	71	G3348T	40
FSP-6557-3	103	G1GUHE03003T	15	G2925-120C	72	G3348T-BMS	40
FSP-9520-3	99	G1GUHE03003T	54	G2925-120S	71	G3348T-BMS-W	41
FSP-9524-3	99	G1GUHE05003T	15	G2925-120SW	71	G3348T-BMSTB	40
FSP-9527-1	99	G1GUHE05003T	54	G3032DWBW	34	G3348T-BMSTB	40
FSP-9548-3	99	G1GUHE07CA1T	15	G3052T2DWB	39	G3348T-W	41
FSP-9557-3	99	G1GUHE07CA1T	54	G3314RP	47	G3383D-RP	34
FSS-1412-1	86	G1GUHE10RA1T	15	G3314RPW	47	G3384D-RP	34
FSS-1420-1	86	G1GUHE10RA1T	54	G3314T2RP	47	G3385D-RP	34
FSS-1424-1	86	G2903-024C	72	G3314T2RPW	47	G3386D-RP	34
FSS-1427-1	86	G2903-024S	71	G3314TRP	47	G3387D-RP	34
FSS-1448-1	86	G2903-024SW	71	G3314TRPW	47	G3422T	44
FSS-1457-1	86	G2905-028C	71	G3315RP	47	G3423T	44
FSS-3120-1	86	G2905-028S	71	G3315RPW	47	G3424T	44
FSS-3124-1	86	G2905-028SW	71	G3315T2RP	47	G3425T	44
FSS-3127-1	86	G2906-036C	72	G3315T2RPW	47	G3452SD	46
FSS-3148-1	86	G2906-036S	71	G3315TRP	47	G3452T	44
FSS-3157-1	86	G2906-036SW	71	G3315TRPW	47	G3453SD	46

Product Index Listing

MODEL	PAGE	MODEL	PAGE	MODEL	PAGE	MODEL	PAGE
G3453T	44	G3915-72	67	G9984-02-300	64	H2906-036S	71
G3454SD	46	G3915-72C	67	G9984-03-200	65	H2906-036SW	71
G3454T	44	G3920-96	67	G9996-01-150	63	H2906-36AWi	71
G3455SD	46	G3920-96C	67	G9996-01-200	63	H2907-040C	72
G3455T	44	G8801050	31	G9996-02-200	64	H2907-040C	72
G3472A1	36	G8802075	31	G9996-02-300	64	H2907-040S	71
G3473A1	36	G8803100	31	G9996-03-200	65	H2907-040SW	71
G3474A1	36	G8804125	31	G9996-03-300	65	H2907-40AWi	71
G3475A1	36	G8805150	31	GF-SK-1	99	H2910-048C	72
G3482A1	35	G8806200	31	H1G7203	121	H2910-048CI	72
G3483A1	35	G99108-01-150	63	H1G7205	121	H2910-048S	71
G3484A1	35	G99108-01-200	63	H1G7305	121	H2910-048SW	71
G3485A1	35	G99108-02-200	64	H1H2605CA1	21	H2910-48AWi	71
G3703-024	68	G99108-02-300	64	H1H2607CA1	21	H2912-060C	72
G3703-024B	68	G99108-03-200	65	H1H2610CA1	21	H2912-060S	71
G3705-028	68	G99108-03-300	65	H1H5503T	11	H2912-060SW	71
G3705-028B	68	G99120-01-150	63	H1H5505T	11	H2912-60AWi	71
G3706-036	68	G99120-01-200	63	H1H5507T	11	H2915-072C	72
G3706-036B	68	G99120-02-200	64	H1H5510T	11	H2915-072CI	72
G3707-040	68	G99120-02-300	64	H1H5515T	11	H2915-072S	71
G3707-040B	68	G99120-03-200	65	H1HUH03003	13	H2915-072SW	71
G3707-048	68	G99120-03-300	65	H1HUH05003	13	H2915-72AWi	71
G3707-048B	68	G9928-01-129	63	H1HUH07CA1	13	H2917-084C	72
G3709-060	68	G9928-01-86	63	H1HUH12C03	13	H2917-084CI	72
G3709-060B	68	G9928-02-172	64	H1HUH15C03	13	H2917-084S	71
G3710-048	68	G9928-03-172	65	H1HUH20CA1	13	H2917-084SW	71
G3710-048B	68	G9936-01-150	63	H1HUH25CA1	13	H2917-84AWi	71
G3711-072	68	G9936-01-200	63	H1HUH30CA1	13	H2920-096C	72
G3711-072B	68	G9936-02-200	64	H1HUHE03003T	15	H2920-096CI	72
G3712-060	68	G9936-02-300	64	H1HUHE03003T	54	H2920-096S	71
G3712-060B	68	G9936-03-200	65	H1HUHE05003T	15	H2920-096SW	71
G3713-084	68	G9936-03-300	65	H1HUHE05003T	54	H2920-120AWi	71
G3713-084B	68	G9948-01-150	63	H1HUHE07CA1T	15	H2925-120C	72
G3715-072	68	G9948-01-200	63	H1HUHE07CA1T	54	H2925-120CI	72
G3715-072B	68	G9948-02-200	64	H1HUHE10CA1T	15	H2925-120S	71
G3715-096	68	G9948-02-300	64	H1HUHE10CA1T	54	H2925-120SW	71
G3715-096B	68	G9948-03-200	65	H1HUHE12C03T	15	H2HUH05C03	13
G3717-084	68	G9948-03-300	65	H1HUHE12C03T	54	H2HUH07C03	13
G3717-084B	68	G9960-01-150	63	H1HUHE15C03T	15	H2HUHE05C03T	15
G3718-120	68	G9960-01-200	63	H1HUHE15C03T	54	H2HUHE05C03T	54
G3718-120B	68	G9960-02-200	64	H2903-024C	72	H2HUHE07C03T	15
G3720-096	68	G9960-02-300	64	H2903-024CI	72	H2HUHE07C03T	54
G3720-096B	68	G9960-03-200	65	H2903-024HAW	57	H3032DWBW	34
G3725-120	68	G9960-03-300	65	H2903-024S	71	H30522T2DWB	39
G3725-120B	68	G9972-01-150	64	H2903-024SW	71	H30522TDWB	39
G3904-28	67	G9972-01-200	63	H2903-24AWi	71	H3052T2DWB	39
G3904-28C	67	G9972-02-200	64	H2905-028C	72	H3052TDWB	39
G3906-36	67	G9972-02-300	64	H2905-028CI	72	H3275RPW	50
G3906-36C	67	G9972-03-200	65	H2905-028S	71	H3275T2RPW	50
G3910-48	67	G9972-03-300	65	H2905-028SW	71	H3317RP	47
G3910-48C	67	G9984-01-150	63	H2905-28AWi	71	H3317RPW	47
G3912-60	67	G9984-01-200	63	H2906-036C	72	H3317T2RP	47
G3912-60C	67	G9984-02-200	64	H2906-036C	72	H3317T2RPW	47

MODEL	PAGE	MODEL	PAGE	MODEL	PAGE	MODEL	PAGE
H3317T2SRP	49	H3715-072B	68	H3H5705T	22, 120	H9948-01-200	63
H3317T2SRPW	49	H3717-084	68	H3HUH03C03	13	H9948-02-200	64
H3317TRP	47	H3717-084B	68	H3HUH12C03	13	H9948-02-300	64
H3317TRPW	47	H3720-096	68	H3HUH15C03	13	H9948-03-200	64
H3317TSRP	49	H3720-096B	68	H3HUH20CA1	13	H9948-03-300	64
H3317TSRPW	49	H3725-120	68	H3HUH25CA1	13	H9960-01-150	63
H3327TD-RP	42	H3725-120B	68	H3HUH30CA1	13	H9960-01-200	63
H3346	40	H3904-28	67	H3HUHE03C03T	15	H9960-02-200	64
H3346-BMS	40	H3904-28C	67	H3HUHE03C03T	54	H9960-02-300	64
H3346-BMS-W	41	H3906-36	67	H3HUHE12C03T	15	H9960-03-200	64
H3346-BMSTB	40	H3906-36C	67	H3HUHE12C03T	54	H9960-03-300	64
H3346-BMSTB	40	H3910-48	67	H3HUHE15C03T	15	H9972-01-150	63
H3346-W	41	H3910-48C	67	H3HUHE15C03T	54	H9972-01-200	63
H3346T	40	H3912-60	67	H46C1166	114	H9972-02-200	64
H3346T-BMS	40	H3912-60C	67	H474TM-C	105	H9972-02-300	64
H3346T-BMS-W	41	H3915-72	67	H5520/HMK	10	H9972-03-200	64
H3346T-BMSTB	40	H3915-72C	67	H5550/HMK	10	H9972-03-300	64
H3346T-BMSTB	40	H3920-96	67	H8801050	31	H9984-01-150	63
H3346T-W	41	H3920-96C	67	H8801050i	31	H9984-01-200	63
H3387D-RP	34	H3G7203	121	H8802075	31	H9984-02-200	64
H3422T	44	H3G7205	121	H8802075i	31	H9984-02-300	64
H3423T	44	H3G7210	121	H8803100	31	H9984-03-200	64
H3424T	44	H3G7210-2	121	H8803100i	31	H9984-03-300	64
H3425T	44	H3G7215	121	H8804125	31	H9996-01-150	63
H3452SD	46	H3G7215-2	121	H8804125i	31	H9996-01-200	63
H3452T	44	H3G7220-2	121	H8805150	31	H9996-02-200	64
H3453SD	46	H3G7223-2	121	H8805150i	31	H9996-02-300	64
H3453T	44	H3G7230-2	121	H8806200	31	H9996-03-200	64
H3454SD	46	H3G7305	121	H8806200i	31	H9996-03-300	64
H3454T	44	H3G7310	121	H99108-01-150	63	HF1B5103N	16, 17
H3455SD	46	H3G7310-2	121	H99108-01-200	63	HF1B5105N	16, 17
H3455T	44	H3G7312	121	H99108-02-200	64	HF2B5103N	16, 17
H3472A1	36	H3G7312-2	121	H99108-02-300	64	HF2B5105N	16, 17
H3473A1	36	H3G7315	121	H99108-03-200	64	HF2B5107CA1L	16, 17
H3474A1	36	H3G7315-2	121	H99108-03-300	64	HF2B5110CA1L	16, 17
H3475A1	36	H3H2605CA1	21	H99120-01-150	63	HF2BUHE10C03T	15
H3482A1	35	H3H2607CA1	21	H99120-01-200	63	HF2BUHE10C03T	15
H3483A1	35	H3H2610CA1	21	H99120-02-200	64	HF2BUHE10C03T	54
H3484A1	35	H3H2615CA1	21	H99120-02-300	64	HF2BUHE10C03T	54
H3485A1	35	H3H2620CA1	21	H99120-03-200	64	HF2HUH10C03	13
H3703-024	68	H3H2625CA1	21	H99120-03-300	64	HF3210RPW	50
H3703-024B	68	H3H2630CA1	21	H9928-01-129	63	HF3210T2RPW	50
H3705-028	68	H3H2640CA1	21	H9928-01-86	63	HF3215RPW	50
H3705-028B	68	H3H2650CA1	21	H9928-02-172	64	HF3215T2RPW	50
H3706-036	68	H3H5503T	11	H9928-03-129	64	HF3220RPW	50
H3706-036B	68	H3H5505T	11	H9928-03-172	64	HF3220T2RPW	50
H3707-040	68	H3H5507T	11	H9936-01-150	63	HF3222RPW	50
H3707-040B	68	H3H5510T	11	H9936-01-200	63	HF3222T2RPW	50
H3710-048	68	H3H5515T	11	H9936-02-200	64	HF3315SRP	47
H3710-048B	68	H3H5520T	11	H9936-02-300	64	HF3315RPW	47
H3712-060	68	H3H5525T	11	H9936-03-200	64	HF3315T2RP	47
H3712-060B	68	H3H5530T	11	H9936-03-300	64	HF3315T2RPW	47
H3715-072	68	H3H5605T	23	H9948-01-150	63	HF3315T2SRP	49

Product Index Listing

MODEL	PAGE	MODEL	PAGE	MODEL	PAGE	MODEL	PAGE
HF3315T2SRPW	49	HF4375T2RP	51	HLP M1525	6	J3348-BMSTB	40
HF3315TRP	47	HF4375T2RPW	51	HLP M37	6	J3348-BMSTB	40
HF3315TRPW	47	HF4375TRP	51	HLT-1	6, 9, 109	J3348-W	41
HF3315SRP	49	HF4375TRPW	51	HLT-2	9, 109	J3348T	40
HF3315TSRPW	49	HF4410T2RP	39	HLWM10	6	J3348T-BMS	40
HF3316RP	47	HF4415T2RP	39	HLWM1525	6	J3348T-BMS-W	41
HF3316RPW	47	HF4420T2RP	39	HLWM37	6	J3348T-BMSTB	40
HF3316T2RP	47	HF4475T2RP	39	HP-11-QT	100	J3348T-BMSTB	40
HF3316T2RPW	47	HF4810RPW	52	HP-5-QT	100	J3348T-W	41
HF3316T2SRP	49	HF4810T2RPW	52	HP-6-QT	100	J3349	40
HF3316T2SRPW	49	HF4815RPW	52	HP6-1000120-2CT	117	J3349-BMS	40
HF3316TRP	47	HF4815T2RPW	52	HP6-1000120-2CTRP	119	J3349-BMS-W	41
HF3316TRPW	47	HF4820RPW	52	HP6-1000120-2T	117	J3349-BMSTB	40
HF3316TSRP	47	HF4820T2RPW	52	HP6-1000120-2TRP	119	J3349-BMSTB	40
HF3316TSRPW	49	HF4875RPW	52	HP8-1440120-2CT	117	J3349-W	41
HF3323TD-RP	42	HF4875T2RPW	52	HP8-1440120-2CTRP	119	J3349T	40
HF3324TD-RP	42	HF5605T	23	HP8-1440120-2T	117	J3349T-BMS	40
HF3325TD-RP	42	HF5705T	22, 120	HP8-1440120-2TRP	119	J3349T-BMS-W	41
HF3326TD-RP	42	HF5840TC	105	HR-F1-7	117	J3349T-BMSTB	40
HF3384D-RP	34	HF5848TC	105	HR-F3-12.2	117	J3349T-BMSTB	40
HF3385D-RP	34	HF684TC	106	HR-F3-8.5	117	J3349T-W	41
HF3386D-RP	34	HF685TC	106	HR-H1-8.1	117	J3422T	44
HF3B51100CA1	19	HF686TC	106	HR-H1-8.5	117	J3423T	44
HF3B5115CA1L	17	HIHUH10CA1	13	HR-H3-14.1	117	J3424T	44
HF3B5120CA1L	17	HLA 12-208160-3.0-24	5	HR-P3-10.0	117	J3425T	44
HF3B5125CA1L	17	HLA 12-208160-5.0-24	5	HR-P3-15.0	117	J3452SD	46
HF3B5130CA1L	17	HLA 12-208160-7.5-24	5	HR-P3-20.0	117	J3452T	44
HF3B5140CA1L	17	HLA 12-208360-3.0-24	5	HR-P3-20.0-2	117	J3453SD	46
HF3B5150CA1L	17	HLA 12-208360-5.0-24	5	HR-P3-24.0	117	J3453T	44
HF3B5160CA1	19	HLA 12-208360-7.5-24	5	ICH-240C	105	J3454SD	46
HF3B5170CA1	19	HLA 12-240160-3.0-24	5	IDS	54	J3454T	44
HF3B5180CA1	19	HLA 12-240160-5.0-24	5	IDS 30	54	J3455SD	46
HF3B5190CA1	19	HLA 12-240160-7.5-24	5	IDS 40	54	J3455T	44
HF4310RP	51	HLA 12-240360-3.0-24	5	ITD	54	J3472A1	36
HF4310RPW	51	HLA 12-240360-5.0-24	5	ITS	54	J3473A1	36
HF4310T2RP	51	HLA 12-240360-7.5-24	5	J3325TD-RP	43	J3474A1	36
HF4310T2RPW	51	HLA 12-480360-3.0-24	5	J3326TD-RP	43	J3475A1	36
HF4310TRP	51	HLA 12-480360-5.0-24	5	J3327TD-RP	43	J3482A1	35
HF4310TRPW	51	HLA 12-480360-7.5-24	5	J3346	40	J3483A1	35
HF4315RP	51	HLA 16-208360-10.0-24	5	J3346-BMS	40	J3484A1	35
HF4315RPW	51	HLA 16-240160-10.0-24	5	J3346-BMS-W	41	J3485A1	35
HF4315T2RP	51	HLA 16-240360-10.0-24	5	J3346-BMSTB	40	J99108-03-200	65
HF4315T2RPW	51	HLA 16-480360-10.0-24	5	J3346-BMSTB	40	J99108-03-300	65
HF4315TRP	51	HLA 20-208360-15.0-24	5	J3346-W	41	J99120-03-200	65
HF4315TRPW	51	HLA 20-240360-15.0-24	5	J3346T	40	J99120-03-300	65
HF4320RP	51	HLA 20-480360-15.0-24	5	J3346T-BMS	40	J9928-03-129	65
HF4320RPW	51	HLA 20-480360-20.0-24	5	J3346T-BMS-W	41	J9928-03-172	65
HF4320T2RP	51	HLA 20-480360-25.0-24	5	J3346T-BMSTB	40	J9936-03-200	65
HF4320T2RPW	51	HLA 20-600360-15.0-24	5	J3346T-BMSTB	40	J9936-03-300	65
HF4320TRP	51	HLA 20-600360-20.0-24	5	J3346T-W	41	J9948-03-200	65
HF4320TRPW	51	HLA 20-600360-25.0-24	5	J3348	40	J9948-03-300	65
HF4375RP	51	HLHM	6	J3348-BMS	40	J9960-03-200	65
HF4375RPW	51	HLP M1015	6	J3348-BMS-W	41	J9960-03-300	65

MODEL	PAGE	MODEL	PAGE	MODEL	PAGE	MODEL	PAGE
J9972-03-200	65	K3453SD	46	LVTR	54	MFHE-0300-6-HAA	119
J9972-03-300	65	K3453T	44	M2903-024CI	72	MFHE-0300-6-HAAF2D	119
J9984-03-200	65	K3454SD	46	M2903-24AWi	71	MFHE-0300-6-HAARP	119
J9984-03-300	65	K3454T	44	M2905-028CI	72	MFHE-0300-8-EAA	119
J9996-03-200	65	K3455SD	46	M2905-28AWi	71	MFHE-0300-8-EAAC	119
J9996-03-300	65	K3455T	44	M2906-036CI	72	MFHE-0300-8-EAACRP	119
JK	73	K3472A1	36	M2906-36AWi	71	MFHE-0300-8-EAARP	119
JKB	73	K3473A1	36	M2907-040CI	72	MFHE-0300-8-HAA	119
JKW	73	K3474A1	36	M2907-40AWi	71	MFHE-0300-8-HAARP	119
K3326TD-RP	43	K3475A1	36	M2910-048CI	72	MM-13A	93
K3327TD-RP	43	K3482A1	35	M2910-48AWi	71	MM-24A	93
K3346	40	K3483A1	35	M2912-060CI	72	MM-33A	93
K3346-BMS	40	K3484A1	35	M2912-60AWi	71	MM-46A	93
K3346-BMS-W	41	K3485A1	35	M2915-072CI	72	MMWG-13	93
K3346-BMSTB	40	K99108-03-200	65	M2915-72AWi	71	MMWG-24	93
K3346-BMSTB	40	K99108-03-300	65	M2917-084CI	72	MMWG-33	93
K3346-W	41	K99120-03-200	65	M2917-84AWi	71	MMWG-46	93
K3346T	40	K99120-03-300	65	M2920-096CI	72	MS4122	33
K3346T-BMS	40	K9928-03-129	65	M2925-120AWi	71	MS4123	33
K3346T-BMS-W	41	K9928-03-172	65	M2925-120CI	72	MS4124	33
K3346T-BMSTB	40	K9936-03-200	65	M3210T2RPWi	50	MS4125	33
K3346T-BMSTB	40	K9936-03-300	65	M3215T2RPWi	50	MS4126	33
K3346T-W	41	K9948-03-200	65	M3220T2RPWi	50	MSE4120-12	33
K3348	40	K9948-03-300	65	M3222T2RPWi	50	N3472T2i	36
K3348-BMS	40	K9960-03-200	65	M3315T2SRPWi	49	N3473T2i	36
K3348-BMS-W	41	K9960-03-300	65	M3316T2SRPWi	49	N3474T2i	36
K3348-BMSTB	40	K9972-03-200	65	M3324TD-RPi	42	N3482T2i	35
K3348-BMSTB	40	K9972-03-300	65	M3325TD-RPi	42	N3483T2i	35
K3348-W	41	K9984-03-200	65	M3384D-RPi	34	N3484T2i	35
K3348T	40	K9984-03-300	65	M3385D-RPi	34	OCH-46-120V-SSE	90
K3348T-BMS	40	K9996-03-200	65	M3386D-RPi	34	OCH-46-120VCE	90
K3348T-BMS-W	41	K9996-03-300	65	M3472T2i	36	OCH-46-120VE	90
K3348T-BMSTB	40	KB33	25	M3473T2i	36	OCH-46-208V-SSE	90
K3348T-BMSTB	40	KB46	25	M3474T2i	36	OCH-46-208VE	90
K3348T-W	41	KB66	25	M3482T2i	35	OCH-46-240V-SSE	90
K3349	40	KB79	25	M3483T2i	35	OCH-46-240VE	90
K3349-BMS	40	KT110	110	M3484T2i	35	OCH-46-277V-SSE	90
K3349-BMS-W	41	KT121	110	M4310T2RPi	51	OCH-46-277VE	90
K3349-BMSTB	40	KTD110	110	M4315T2RPi	51	OCH-57-208V-SSE	90
K3349-BMSTB	40	KTO110	110	M4320T2RPi	51	OCH-57-208VCE	90
K3349-W	41	KTO121	110	M4375T2RPi	51	OCH-57-208VE	90
K3349T	40	L8801050	31	M8801050i	31	OCH-57-240V-SSE	90
K3349T-BMS	40	L8802075	31	M8802075i	31	OCH-57-240VCE	90
K3349T-BMS-W	41	L8803100	31	M8803100i	31	OCH-57-240VE	90
K3349T-BMSTB	40	L8804125	31	M8804125i	31	OCH-57-277V-SSE	90
K3349T-BMSTB	40	L8805150	31	M8805150i	31	OCH-57-277VE	90
K3349T-W	41	L8806200	31	M8806200i	31	OCH-57-480V-SSE	90
K3422T	44	LB110	114	MCS120-8CT	118	OCH-57-480VE	90
K3423T	44	LB210	114	MFHE-0300-6-EAA	119	OCH2-55-208V	92
K3424T	44	LRD100A	114	MFHE-0300-6-EAAC	119	OCH2-55-208V-SS	92
K3425T	44	LVR5	73	MFHE-0300-6-EAACRP	119	OCH2-55-240V	92
K3452SD	46	LVR5B	73	MFHE-0300-6-EAARP	119	OCH2-55-240V-SS	92
K3452T	44	LVR5W	73	MFHE-0300-6-FAAF2D	119	OCH2-55-277V	92

Product Index Listing

MODEL	PAGE	MODEL	PAGE	MODEL	PAGE	MODEL	PAGE
OCH2-55-277V-SS	92	P3349T-BMSTB	40	P3P5170CA1	19	P3PUHE10CA1T	54
OCH2-55-480V	92	P3349T-BMSTB	40	P3P5180CA1	19	P3PUHE12CA1T	15
OCH2-55-480V-SS	92	P3349T-W	41	P3P5190CA1	19	P3PUHE12CA1T	54
OCH2-66-208V	92	P3372TD-RP	43	P3P5503T	11	P3PUHE15CA1T	15
OCH2-66-208V-SS	92	P3472A1	36	P3P5505T	11	P3PUHE15CA1T	54
OCH2-66-240V	92	P3473A1	36	P3P5507T	11	P5520/PMK	10
OCH2-66-240V-SS	92	P3474A1	36	P3P5510T	11	P5550/PMK	10
OCH2-66-277V	92	P3475A1	36	P3P5515T	11	P8801050	31
OCH2-66-277V-SS	92	P3482A1	35	P3P5520T	11	P8802075	31
OCH2-66-480V	92	P3483A1	35	P3P5525T	11	P8803100	31
OCH2-66-480V-SS	92	P3484A1	35	P3P5530T	11	P8804125	31
OCHWG-46	90	P3485A1	35	P3P5540T	11	P8805150	31
OCHWG-57	90	P399108-03-200	65	P3P5548T	11	P8806200	31
OFG 51100	18	P399108-03-300	65	P3P5605T	23	P99108-01-150	63
OFG 5175	18	P399120-03-200	65	P3P5705T	22, 112	P99108-01-200	63
OFG5101	15	P399120-03-300	65	P3P7205	121	P99108-02-200	64
OFG5102	15	P39928-03-172	65	P3P7210-2	121	P99108-02-300	64
OFG5103	15	P39936-03-200	65	P3P7215	121	P99108-03-300	65
P3325TD-RP	43	P39936-03-300	65	P3P7215-2	121	P99120-01-150	63
P3326TD-RP	43	P39948-03-200	65	P3P7220-2	121	P99120-01-200	63
P3346	40	P39948-03-300	65	P3P7225-2	121	P99120-02-200	64
P3346-BMS	40	P39960-03-200	65	P3P7230-2	121	P99120-02-300	64
P3346-BMS-W	41	P39960-03-300	65	P3P7235-2	121	P99120-03-300	65
P3346-BMSTB	40	P39972-03-200	65	P3P7240-2	121	P9936-01-150	63
P3346-BMSTB	40	P39972-03-300	65	P3P7245-2	121	P9936-01-200	63
P3346-W	41	P39984-03-200	65	P3P7250-2	121	P9936-02-200	64
P3346T	40	P39984-03-300	65	P3P7305	121	P9936-02-300	64
P3346T-BMS	40	P39996-03-200	65	P3P7310	121	P9936-03-300	65
P3346T-BMS-W	41	P39996-03-300	65	P3P7310-2	121	P9948-01-150	63
P3346T-BMSTB	40	P3G7210	121	P3P7312	121	P9948-01-200	63
P3346T-BMSTB	40	P3P2605CA1	21	P3P7312-2	121	P9948-02-200	64
P3346T-W	41	P3P2607CA1	21	P3P7315	121	P9948-02-300	64
P3348	40	P3P2610CA1	21	P3P7315-2	121	P9948-03-300	65
P3348-BMS	40	P3P2615CA1	21	P3P7318	121	P9960-01-150	63
P3348-BMS-W	41	P3P2620CA1	21	P3P7318-2	121	P9960-01-200	63
P3348-BMSTB	40	P3P2625CA1	21	P3PUH03CA1	13	P9960-02-200	64
P3348-BMSTB	40	P3P2630CA1	21	P3PUH05CA1	13	P9960-02-300	64
P3348-W	41	P3P2640CA1	21	P3PUH07CA1	13	P9960-03-300	65
P3348T	40	P3P2650CA1	21	P3PUH10CA1	13	P9972-01-150	63
P3348T-BMS	40	P3P5103CA1N	16, 17	P3PUH12CA1	13	P9972-01-200	63
P3348T-BMS-W	41	P3P5105CA1N	16, 17	P3PUH15CA1	13	P9972-02-200	64
P3348T-BMSTB	40	P3P5107CA1L	17	P3PUH20CA1	13	P9972-02-300	64
P3348T-BMSTB	40	P3P5107CA1N	16	P3PUH25CA1	13	P9972-03-300	65
P3348T-W	41	P3P51100CA1	19	P3PUH30CA1	13	P9984-01-150	63
P3349	40	P3P5110CA1N	16, 17	P3PUH40CA1	13	P9984-01-200	63
P3349-BMS	40	P3P5115CA1L	17	P3PUH48CA1	13	P9984-02-200	64
P3349-BMS-W	41	P3P5115CA1N	16	P3PUHE03CA1T	15	P9984-02-300	64
P3349-BMSTB	40	P3P5120CA1N	16, 17	P3PUHE03CA1T	54	P9984-03-300	65
P3349-BMSTB	40	P3P5125CA1N	16, 17	P3PUHE05CA1T	15	P9996-01-150	63
P3349-W	41	P3P5130CA1N	16, 17	P3PUHE05CA1T	54	P9996-01-200	63
P3349T	40	P3P5140CA1N	16, 17	P3PUHE07CA1T	15	P9996-02-200	64
P3349T-BMS	40	P3P5150CA1N	16, 17	P3PUHE07CA1T	54	P9996-02-300	64
P3349T-BMS-W	41	P3P5160CA1	19	P3PUHE10CA1T	15	P9996-03-300	65

MODEL	PAGE	MODEL	PAGE	MODEL	PAGE	MODEL	PAGE
PCH-48C	100	PT3480	35	RDBT-PDIECR	60	SR120	73
PD-128-3	124	Q3H5103CA1	16	RDBT-PDOC	60	SR120B	73
PD10-1810-1	124	Q3H5105CA1	16	RH1505D0	115	SR120W	73
PD10-1812-3	124	Q3H5107CA1	16	RH3	115	SR220	73
PD15-1812-1	124	Q3H5110CA1	16	RH35	115	SR220B	73
PD15-1812-1-3	124	R3H5103CA1	16	RH3A	115	SR220W	73
PD15-1812-2-3	124	R3H5105CA1	16	RHG-1012A	100	SR220W	69
PD20-2012-1	124	R3H5107CA1	16	RK120EAA	111	T1	8
PD20-2012-3	124	R3H5110CA1	16	RK124EAA	111	T2	8
PD25-2016-1	124	RCP122	37	RK130EAA	111	T4398A1021	111
PD25-2016-3	124	RCP122i	37	RK134EAA	111	T5100	17
PD30-2416-2-3	124	RCP123	37	RKWP1AA	111	T5102	17
PD30-2416-3-3	124	RCP123i	37	RMF-222-A	84	T5122	17
PD35-2416-3	124	RCP125	37	RMF-222-SS-A	84	TAT-24-FAN-120V-1	116
PD40-2416-3	124	RCP125i	37	RMF-223	84	TAT-30/1T	116
PD45-3016-3	124	RCP127	37	RMF-223-SS	84	TAT-45/1T	116
PD5-128-1	124	RCP127i	37	RMF-342-A	84	TB3000	34
PD50-3016-3	124	RCP2202i	37	RMF-342-SS-A	84	TB3380	34
PHLA12-208160-3.0-24-TDP	7	RCP2203i	37	RMF-343	84	TBD	73
PHLA12-208160-5.0-24-TDP	7	RCP2205i	37	RMF-343-SS	84	TBS	73
PHLA12-208160-7.5-24-TDP	7	RCP2207i	37	RMF-462-A	84	TC1602	17, 21
PHLA12-208360-3.0-24-TDP	7	RCP702	37	RMF-462-SS-A	84	TC5102	17, 19
PHLA12-208360-5.0-24-TDP	7	RCP703	37	RMF-463	84	TC5103	17
PHLA12-208360-7.5-24-TDP	7	RCP705	37	RMF-463-SS	84	TF-33	25
PHLA12-240160-3.0-24-TDP	7	RCP707	37	RPH-120-A	93	TF-46	25
PHLA12-240160-5.0-24-TDP	7	RCP802	37	RPH-208-A	93	TF-66	25
PHLA12-240160-7.5-24-TDP	7	RCP803	37	RPH-240-A	93	TF-79	25
PHLA12-240360-3.0-24-TDP	7	RCP805	37	RPH1-5A	106	TFSS101	17, 19
PHLA12-240360-5.0-24-TDP	7	RCP807	37	RPH2-5A	106	TFSS102	17
PHLA12-240360-7.5-24-TDP	7	RD5120	15	RPH22-5Ai	106	TG1	115
PHLA12-480360-3.0-24-TDP	7	RD5150	15	S2022H10AA	109	TG1B	115
PHLA12-480360-5.0-24-TDP	7	RD5175	15	S2022H10AB	109	TG2	115
PHLA12-480360-7.5-24-TDP	7	RDBT-PD-10	60	S2025H10AA	17, 109	TG3	115
PHLA12-600360-3.0-24-TDP	7	RDBT-PD-1000BS	60	SB-6	118	TG3B	115
PHLA12-600360-5.0-24-TDP	7	RDBT-PD-100BS	60	SB-8	118	TG4	115
PHLA12-600360-7.5-24-TDP	7	RDBT-PD-2	60	SB6-120-CT	118	TG5	115
PHLA16-208360-10.0-24-TDP	7	RDBT-PD-200BS	60	SB6-120-T	118	TG6	115
PHLA16-240160-10.0-24-TDP	7	RDBT-PD-3	60	SB8-120-CT	118	TL8230A1003	111
PHLA16-240360-10.0-24-TDP	7	RDBT-PD-300BS	60	SB8-120-T	118	TO-SK-1	99
PHLA16-480360-10.0-24-TDP	7	RDBT-PD-4	60	SC5100	19	TSH1TX	107
PHLA16-600360-10.0-24-TDP	7	RDBT-PD-400BS	60	SDHW1001	112	TSH20J	107
PHLA20-208360-15.0-24-TDP	7	RDBT-PD-5	60	SDHW1002	112	TSH20JW	107
PHLA20-240360-15.0-24-TDP	7	RDBT-PD-500BS	60	SF200	37	TSH2TX	107
PHLA20-480360-15.0-24-TDP	7	RDBT-PD-6	60	SF400	37	TUH1	12
PHLA20-480360-20.0-24-TDP	7	RDBT-PD-600BS	60	SO 12/4	99, 102	TW123	17
PHLA20-480360-25.0-24-TDP	7	RDBT-PD-7	60	SO 14/3	99	TW145	110
PHLA20-600360-15.0-24-TDP	7	RDBT-PD-700BS	60	SO 14/4	99	TW146	110
PHLA20-600360-20.0-24-TDP	7	RDBT-PD-8	60	SO 2/4	102	TW1512	17
PHLA20-600360-25.0-24-TDP	7	RDBT-PD-800BS	60	SO 4/3	102	TW155A	11, 110
PR 120-277/120	54	RDBT-PD-9	60	SO 4/4	99	TW255A	11, 110
PR 120-277/24	54	RDBT-PD-900BS	60	SO 6/4	102	U8801050	31
PR 120-277/240	54	RDBT-PDIC	60	SO 8/3	99	U8802075	31
Pro1 T721	116	RDBT-PDIECL	60	SO 8/4	99	U8803100	31

