

INSTALLATION AND OPERATION INSTRUCTIONS ARCHITECTURAL DRAFT BARRIERS SERIES RDBT

INSTALLATION INSTRUCTIONS



TPI Corporation
P.O. Box 4973
Johnson City, TN
37602-4973

America's Comfort Conditioning Company

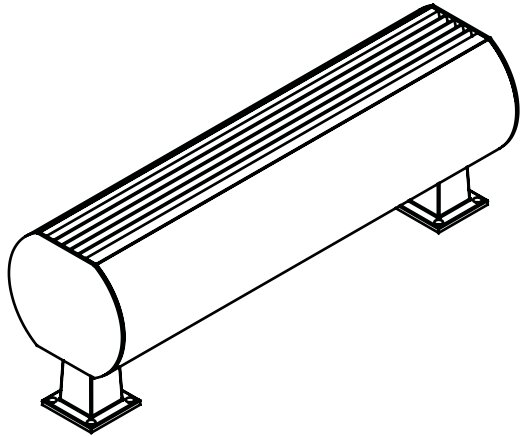

NOT FOR RESIDENTIAL USE

GENERAL:

Series RDBT draft barrier heaters may be mounted individually, end to end and wall to wall. Each heater is factory pre-wired, ready for branch circuit connection. The RDBT heaters are constructed of 12 gauge aluminum and are equipped with an aluminum finned heating element, automatic reset thermal cut-outs and are available with optional relays, disconnect switch, and transformer relays. Integral thermostat and disconnect switch are also available as accessories.

CONTROLS:

DESCRIPTION: Single Pole Thermostat
CATALOG NO.: DBF/DBT-ITS
RATED 25 AMPS AT 120-277. 50-90°F
Temperature range. Tamperproof
and adjustable thru discharge louver.

DESCRIPTION: DISCONNECT SWITCH
CATALOG NO.: DBF/DBT-IDS
DOUBLE POLE RATED 20 AMPS AT
120-277V. Switch is derated to 16A
operating current per N.E.C.

DESCRIPTION: Double Pole Thermostat
CATALOG NO.: DBF/DBT-ITD
RATED 25 AMPS AT 120-277. 50-90°F
Temperature range. tamperproof
and adjustable thru discharge louver.

NOTE: When heaters are furnished with controls, make certain that the heater or heaters do not exceed the lowest amperage rating of the controls furnished. For example, if a thermostat and disconnect are furnished, the thermostat is rated at 25 amps, the disconnect is rated 16 amps, the combination of heaters should not exceed 16 amps.

IMPORTANT INSTRUCTIONS

WHEN USING ELECTRICAL APPLIANCES, BASIC PRECAUTIONS SHOULD ALWAYS BE FOLLOWED TO REDUCE THE RISK OF FIRE, ELECTRIC SHOCK, AND INJURY TO PERSONS, INCLUDING THE FOLLOWING:

1. Read all instructions before using this heater.
2. A heater has hot and arcing or sparking parts inside. Do not use it in areas where gasoline, paint, or flammable liquids are used or stored.
3. This heater is hot when in use. To avoid burns, do not let bare skin touch hot surfaces. If provided, use handles when moving this heater. Keep combustible materials, such as furniture, pillows, bedding, papers, clothes, and curtains away from heater.
4. To prevent a possible fire, do not block air intakes or exhaust in any manner. Do not use on soft surfaces, like a bed, where openings may become blocked.
5. Do not insert or allow foreign objects to enter any ventilation or exhaust openings as this may cause an electric shock or fire, or damage the heater.
6. **"SAVE THESE INSTRUCTIONS"**

CAUTION: HIGH TEMPERATURES

KEEP ELECTRICAL CORDS, FURNITURE, DRAPERIES OR ANY OTHER BLOCKING MATERIAL AWAY FROM HEATER. DO NOT INSTALL HEATERS AGAINST PAPERBOARD OR LOW DENSITY FIBERBOARD SURFACES. DO NOT PLACE HEATER BELOW ELECTRICAL CONVENIENCE RECEPTACLE.

ROUGH-IN WIRING:

1. Run branch circuit of proper voltage and wire size to box of the heater. Power can be entered on either end of the heater. The table below provides correct wire size for wire entry.

TABLE 1.

		MAXIMUM WATTS PER CIRCUIT USING 75°C WIRE				
		WIRE SIZE	120V	208V	240V	277V
COPPER WIRE	14	1440	2496	2880	3324	
	12	1920	3328	3840	4432	
	10	2880	4992	5760	6648	

2. Wire entry into a draft barrier installation is commonly made into one draft barrier heater. Trough wiring (factory furnished) is used for connection to adjacent heaters.
3. Knockouts are located at each end of the heater back panel for wire entry. A knockout is also located on each side of the junction box.
4. All wiring and electrical grounding of the heater back panel to be in accordance with National Electrical Code and/or authority having jurisdiction. A grounding terminal in each heater splice compartment is provided for this purpose.

INSTALLATION OF RDBT HEATERS

1. Once installation location has been determined, the heater(s) should be anchored to the floor using the hardware appropriate for the flooring material. The RDBT series must be mounted on pedestals which are included.
2. When multiple heaters are to be wired together, remove terminal box end knockouts.
3. Mount the back panel to the wall using suitable fasteners (by installer).
4. When heater sections are mounted end to end, install a chase nipple and locknut in the terminal box end knockouts to insure grounding continuity and to protect the wiring. where heater sections are spaced apart, rigid conduit (by installer) should be used to enclose the wire and insure grounding continuity. Use rigid conduit (by installer) when wiring through corner sections to enclose wire and insure grounding continuity.

WIRING DIAGRAMS

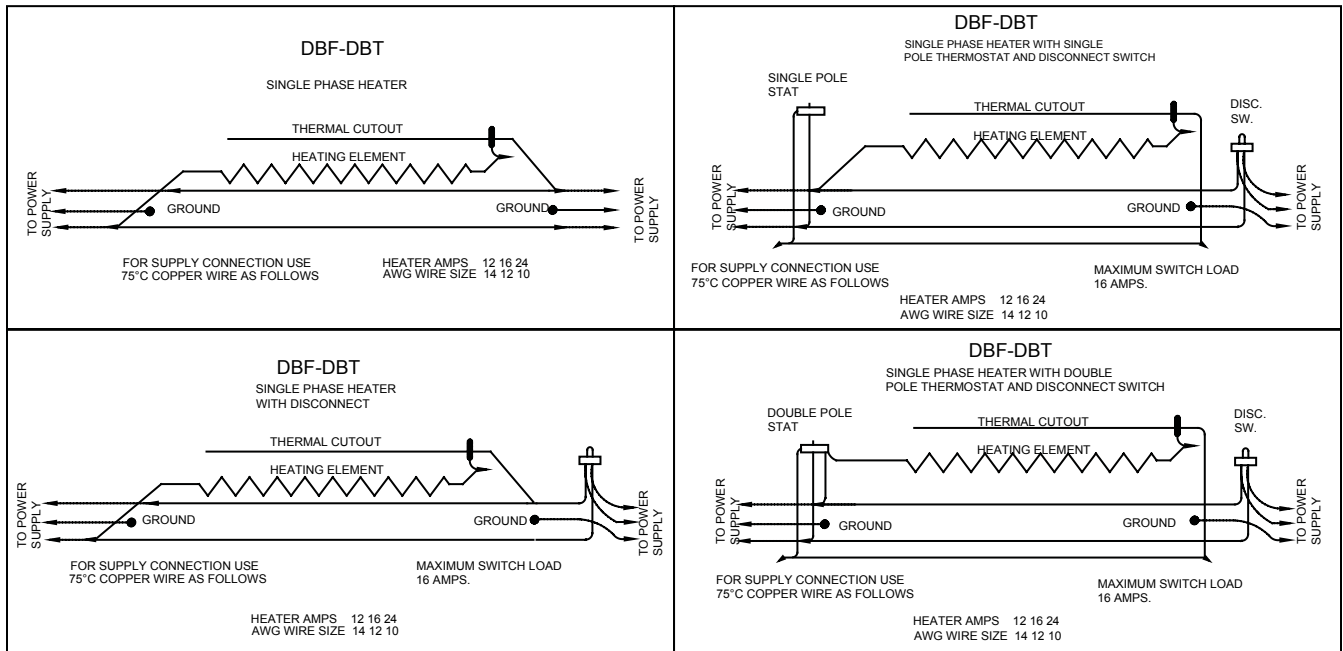

WIRING DIAGRAMS-CONTROL SECTION

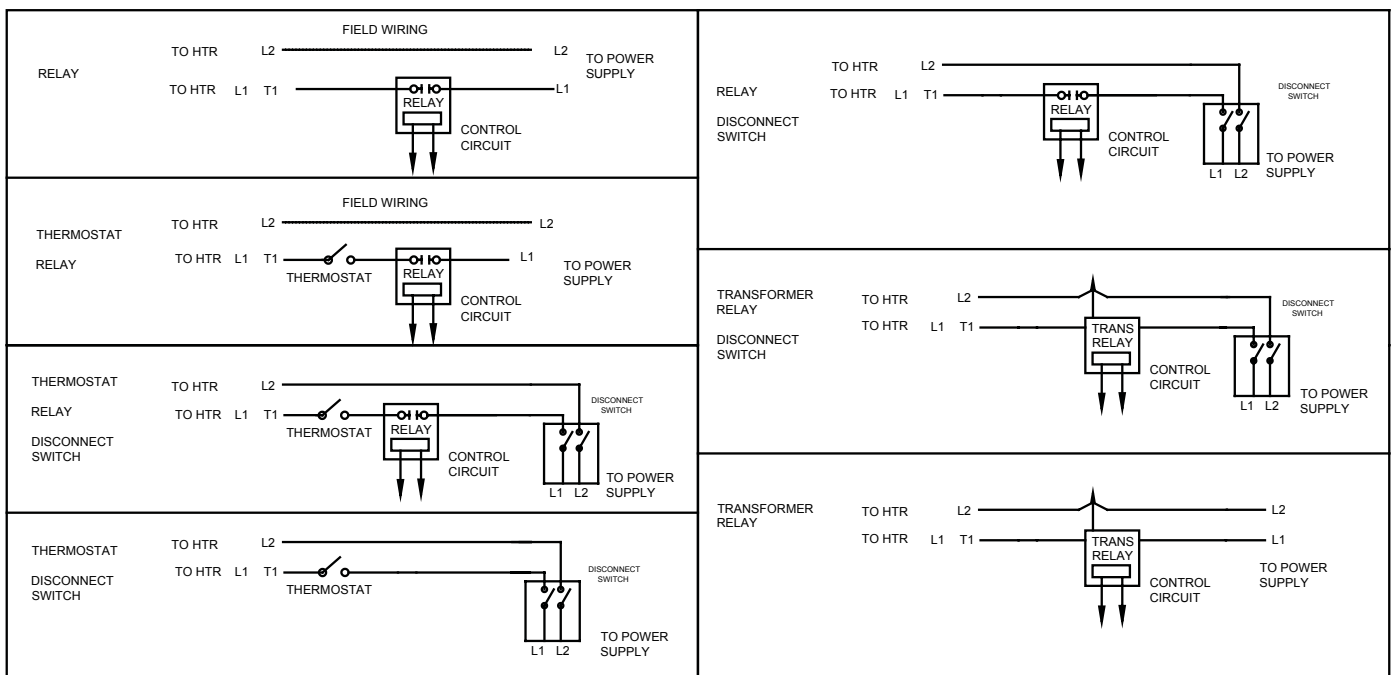

DIMENSIONS

**ARCHITECTURAL PEDESTAL HEATERS
SERIES RDBT
100 - 300 WATTS PER FOOT**

