



Industrial Air Circulator Instructions

All Industrial and Heavy Duty Fan Heads
with hinged grilles and remote switch

READ AND SAVE THESE IMPORTANT INSTRUCTIONS

- It is recommended that you follow safety instructions:
- ALWAYS unplug unit for cleaning, wipe with damp cloth and mild detergent.
- ALWAYS unplug when not in use.
- ALWAYS unplug when moving fan from one location to the next.
- DO NOT allow unit to become wet or damp.
- DO NOT oil, motor is permanently lubricated.
- DO NOT put foreign objects through fan guards into blade.
- DO NOT operate any fan with a damaged cord or plug. Discard fan or return to an authorized service facility for examination and/or repair.
- DO NOT run cord under carpeting.
- DO NOT cover cord with throw rugs, runners or similar coverings.
- DO NOT route cord under furniture or appliances. Arrange cord away from traffic area and where it will not be tripped over.

WARNING: To reduce risk of fire and electrical shock, **DO NOT** use this fan with a solid state speed control device. Plug unit into properly rated service outlet.

“NOT SUITABLE FOR USE WITH SOLID-STATE SPEED CONTROLS”

“AVERTISSEMENT; NE CONVIENT PAS A DES REGULATEURS DE VITESSE A SEMI-CONDUCTEURS”

WARNING: TO REDUCE THE RISK OF FIRE, ELECTRICAL SHOCK OR INJURY TO PERSONS, OBSERVE THE FOLLOWING: Do not use replacement parts that have not been recommended by the manufacturer (e.g. parts made at home using a 3D printer).

AVERTISSEMENT : POUR RÉDUIRE LE RISQUE D'INCENDIE, D'ÉLECTROCUTION OU DE BLESSURE AUX PERSONNES, OBSERVEZ CE QUI SUIT : N'utilisez pas de pièces de rechange qui n'ont pas été recommandées par le fabricant.

READ ALL ASSEMBLY INSTRUCTIONS PROVIDED WITH ALL ACCESSORIES BEFORE BEGINNING WITH THE ASSEMBLY OF THE FAN. NEVER USE AN OSCILLATING MOTOR IN CONJUNCTION WITH A MOUNT WHICH WILL SUSPEND THE OSCILLATING MOTOR IN THE UPSIDE DOWN POSITION SUCH AS A CEILING OR I-BEAM MOUNT. NEVER USE AN OSCILLATING MOTOR WITH MORE THAN A 30-DEGREE DOWNWARD TILT.

ASSEMBLY INSTRUCTIONS

Before assembling fan head, mount must be fully assembled and installed as indicated in the instructions provided with mount.

Mount the motor to the applicable mount using the 1/2"-13 x 1" bolt, 1/2" lock washers, 1/2" hex nuts, 1/4"-20 x 1" bolt, 1/4" lock washers and 1/4" hex nuts provided. Reference illustration below.

Mount rear and front hinged grilles (with hinge located at 3 o'clock, 6 o'clock or 9 o'clock position underlined position preferred) using the flat washer, lock washers (optional with some assemblies) and hex nuts provided. Reference to illustration below.

Place the fan blade onto the motor shaft. The CONCAVE or CUPPED portion of the blade's paddles should face away from the motor. Position blade onto shaft so that there is equal distance between the front and rear guards to the blade. Securely tighten the set screw against the flat on the motor shaft. DO NOT TIGHTEN SET SCREW TO ROUNDED PORTION OF SHAFT. Reference illustration below.

Close front grille to rear grille and close the six guard clips on the flange of the grille. Install provided wire tie and attached to opposite end of the flange from the hinge to lock the flange together.

Connect motor cord to the power cord, if assembly has a two piece power cord. Plug directly into a properly rated service outlet.

OPERATING INSTRUCTIONS

The speed of the fan can be controlled by the drop down rocker switch, (high, off, low). If using the extension cord make sure the retaining clips are attached to the opposite end of each neck of the mating plug. This requirement applies to the power cord as well.

The angle of the fan may be adjusted up and down by loosening the 1/4" and 1/2" motor mount bolts. Position fan head into desired direction and securely tighten motor mount bolts.

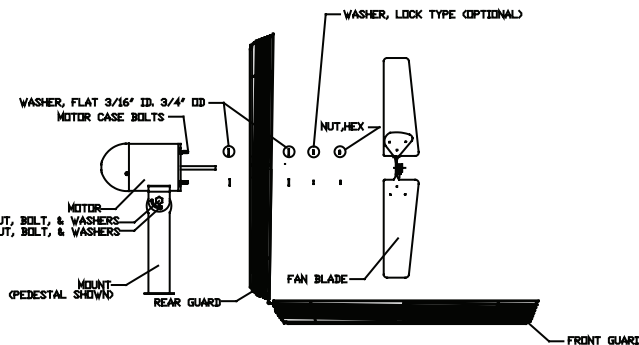

FORM: 8380
ECO 1-8027

FAN BLADE TRACKING INSTRUCTIONS

To ensure smooth operation it is recommended that the fan blade be tracked before initial uses. Refer to the illustrations and instructions below.

ALWAYS DISCONNECT THE FAN FROM ALL POWER SOURCES BEFORE TRACKING THE FAN BLADE. NEVER OPERATE THE FAN WITHOUT ALL FAN GUARDS PROPERLY IN PLACE.

IMPORTANT: Do not attach fan front guard until blade tracking is complete.

Track each paddle of the blade, by using a small ruler or similar measuring device to measure the distance between the rear guard and the leading edge (edge of fan blade paddle leaning closest to rear guard - left edge of paddle as looking at blade through rear guard) of each fan blade paddle. Refer to illustrations below.

Insert the measuring device through rear fan guard into the leading edge of fan blade paddle allowing measuring device to rest against rib of guard. Measurements shall be taken by leaving measuring device at the same location; while rotating fan bade counterclockwise to measure the distance between the rear guard and the leading edge of each paddle. It is recommended that two measurements be taken on each paddle: 1.) near outer tip of fan blade paddle, 2.) near inside (toward center of fan blade) of fan blade paddle. Refer to illustrations below.

If the measured distance between the rear guard and the leading edge of each fan paddle varies less than 1/8" the blade does not require tracking. If the measured distance between the rear guard and the leading edge of each fan paddle varies more than 1/8" the blade requires tracking to allow all fan paddles to rotate within the same plane.

When moving the paddle of the blade which requires tracking, back into track, carefully adjust blade paddle by hand. AT THE SPIDER OF THE HUB near the motor shaft. DO NOT BEND THE FAN PADDLE, since this may contribute to poor performance and/or rough operation. After tracking the blade, assemble front guard and check the fan's operation. Repeat as necessary to achieve best performance.

For additional information on TPI Products or replacement parts, call TPI Customer Service Department at 1-800-251-0382 or write the address below.

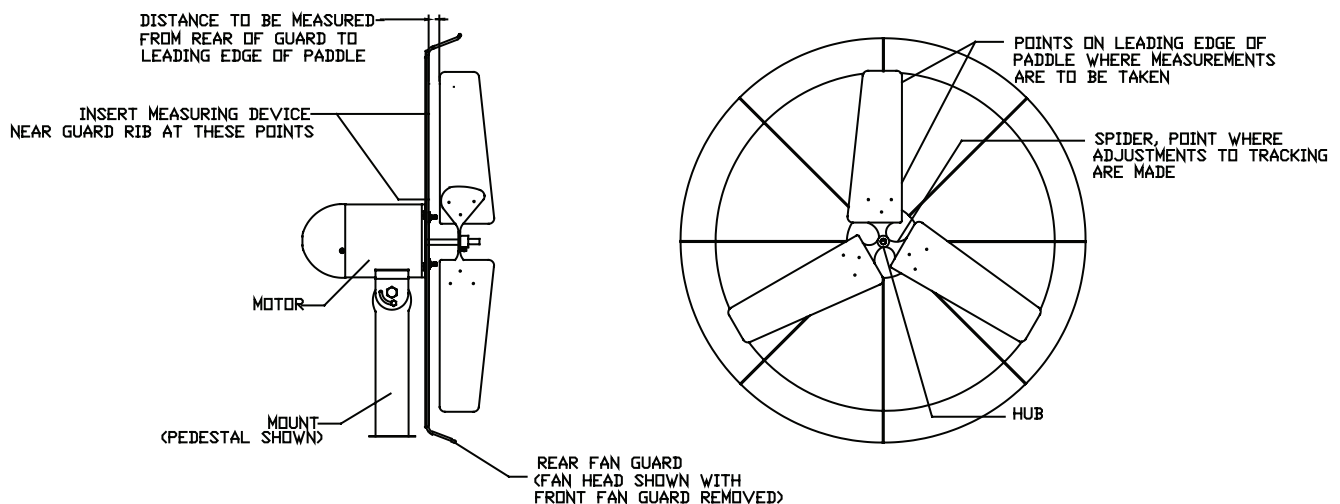

IMPORTANT NOTE: THE LEADING EDGE OF THE FAN BLADE PADDLE IS THE EDGE OF THE PADDLE WHICH LEANS CLOSEST TO THE REAR GUARD - THE LEFT EDGE OF THE FAN BLADE PADDLE AS LOOKING AT THE BLADE THROUGH THE REAR GUARD.