

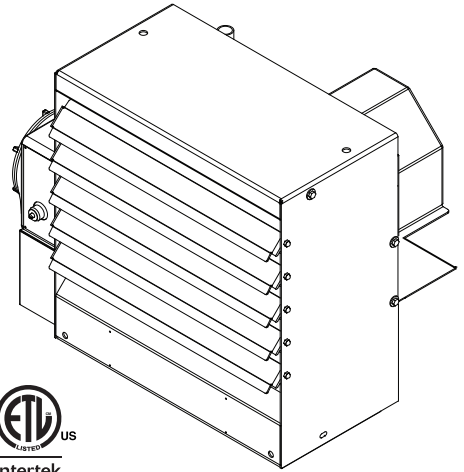

MADE IN THE U.S.A.

HLA SERIES
HAZARDOUS LOCATION
FAN FORCED UNIT HEATER

CUSTOMER		DATE:	
PROJECT			
LOCATION			
ARCHITECT			
ENGINEER			
CONTRACTOR			
SUBMITTED BY			
APPROVED BY			
APPROVED BY			



SUBMITTAL DATA SHEET

QTY	TAG	MODEL	WATTAGE	VOLTS	PHASE	AMPS	DISCONNECT	THERMOSTAT	BRACKET	OPTIONS

NOTES/SPECIAL INSTRUCTIONS:

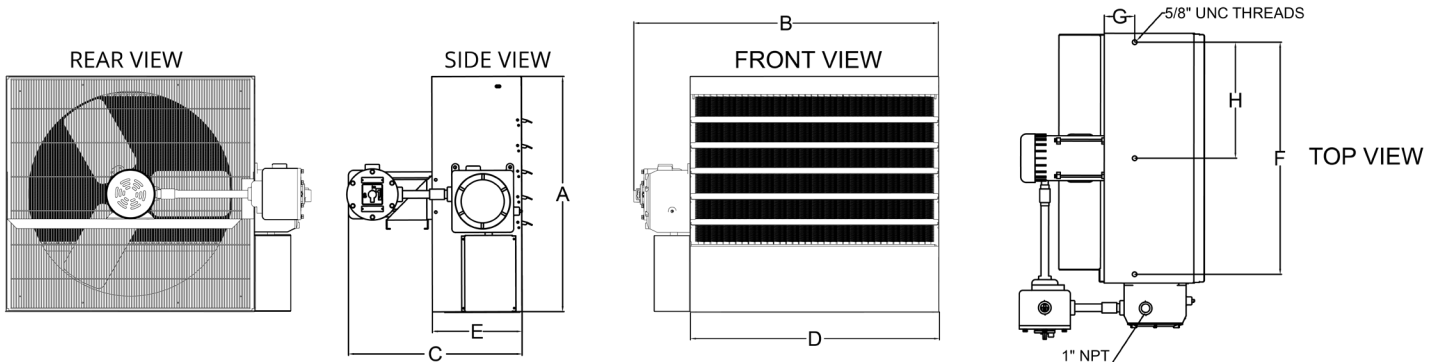

MODEL	DIMENSIONS (INCHES)								
	A	B	C		D	E	F	G	H
			3PH	1PH					
HLA 12	17 3/4	22 3/8	19 3/4	20 5/8	16 1/4	10 1/2	14	3	N/A
HLA 16	20 3/4	26 3/8	20 3/4	21 5/8	20 1/4	11 1/2	18	4	N/A
HLA 20	24 3/4	30 3/8	22 1/2	N/A	24 1/4	12 1/2	22	4 1/2	N/A
HLA 24	30 3/16	34 1/2	24 1/4	N/A	31 1/4	12 1/2	28 3/4	4 1/4	14 3/8
HLA 28	32 7/8	40 3/4	24 1/4	N/A	34 3/4	12 1/2	32 7/16	4 1/4	16 5/32

- Designed for rugged industrial applications in hazardous locations where the possibility of explosion or fire exists due to the presence of certain flammable gases, vapors, powdered metals, or dust
- Permanently sealed, liquid to air, finned tube heat exchanger core
- Ethylene Glycol to water mixture used as a heat transfer fluid in the heater core, providing -45°C (-49°F) freeze damage protection
- High-performance electric motor driven fan blows air across finned tubes to effect uniform heat transfer and area heat distribution
- Manual reset capillary type limit provides high temperature regulation and is rated for 6,000 cycles of service
- Stainless steel and aluminum pressure relief valve for overpressure
- A back-up contactor is included for additional protection
- 14 gauge steel cabinet powder coated epoxy paint finish contains heater core, motor, and fan assembly
- Narrow gap safety fan guard shields all moving parts
- Adjustable louvers allow directional control of air
- Copper conductor wires enclosed in rigid metal conduits carry all electrical power
- Box lugs furnished for field connections within approved enclosure

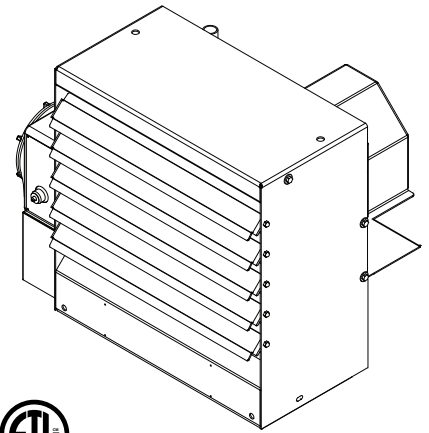

Rating T-3B Class I, Group C&D,
Division 1&2 Class II, Groups E, F & G,
Divisions 1&2

Rating Definitions

CLASS I: Equipment does not have surface operating temperature in excess of the ignition temperature of the specific gas or vapor.

Application Examples:

- Offshore and land based drilling rigs, petroleum exploration and testing facilities.
- Petroleum refineries, gasoline storage and dispensing areas.
- Industrial firms that use flammable liquids in dip tanks for parts cleaning or other operations.
- Petrochemical companies that manufacture chemicals from gas or oil.
- Dry cleaning facilities where vapors from cleaning fluids may be present.
- Aircraft hangers and fuel servicing areas.
- Utility gas plants and operations involving storage and handling of liquefied petroleum or natural gas.

GROUP C: Atmospheres such as but not limited to acetaldehyde, allyl alcohol, hydrogen sulfide, ethylene, carbon monoxide, or other gases or vapors of equivalent hazard.

GROUP D: Atmospheres such as but not limited to acetone, alcohol, gasoline, lacquer solvent vapors, natural gas, propane or other gases or vapors of equivalent hazard.

CLASS II: Equipment does not have surface temperature greater than the ignition temperature of the specified dust.

Application Examples:

- Coal preparation plants and other carbon handling or processing areas.
- Grain elevators, flour and feed mills.
- Plants which manufacture, use or store Magnesium or Aluminum powders.
- Plants that have chemical or metallurgical processes.
- Producers of starch products or candy.
- Spice grinding plants, sugar plants and cocoa plants.

GROUP E: Atmosphere containing combustible metal dust regardless of resistivity, or other combustible dust of similar hazard characteristics having resistivity of less than 10^5 OHM - Centimeter.

GROUP F: Atmosphere containing carbon black, charcoal, coal or coke dust.

GROUP G: Atmospheres containing combustible dust having resistivity of 10^5 OHM-Centimeter or greater.

DIVISION I: A location in which ignitable concentrations of flammable material exist under normal operating conditions.

DIVISION II: Locations in which flammable materials will normally be confined within closed containers and escape only in the case of accidental rupture, breakdown or during maintenance operations. Any equipment approved for Division I is automatically also approved for Division II.

Product Specifications

Heat Exchanger and Elements:

Heavy walled, painted carbon steel with aluminum fins liquid heat exchanger, liquid filled with three-immersion type copper sheathed elements. The elements shall have the highest quality nickel-chromium resistance wire encased in a magnesium oxide dielectric and be hermetically sealed into the heat exchanger core. The heat transfer fluid is Ethylene-glycol solution for operation to -49 degrees F (- 45 degrees C). Stainless steel and aluminum pressure relief valve for overpressure.

Thermal Cutout High Limit Protection and Optional Pilot Light:

The capillary type manual reset thermal cutout shall be rated for 6000 cycles of service and mounted in the liquid filled heat exchanger. An optional pilot light to indicate manual reset tripped, if safe operating temperatures are exceeded, is located on control enclosure.

Motor:

The motor shall be a permanent split capacitor type, permanently lubricated, ball bearing type. The motor shall be rated for hazardous location and operate at rated voltage of heater, 60 Hz, 1725 RPM.

Control Enclosure:

All controls shall be factory installed and wired in a hazardous location enclosure. Contactors and back-up contactors are heavy duty type and break all ungrounded conductors and be rated for 100,000 cycles at full load. Standard 24-Volt control circuit shall be supplied by internal class II transformer. An optional factory wired integral thermostat or standard terminal block for field wiring to optional remote wall thermostat are wired in control panel. No fan delay relay.

Disconnect Switch:

Factory mounted and wired hazardous location disconnect switch is available as optional accessory.

Cabinet With Adjustable Louvers:

The Cabinet shall be 14 gauge, cold rolled steel with powder coated epoxy finish. Plated fan guards with less than 1/4 inch spacing to cover motor and fan shall conform to OSHA Requirements.

Note:

Before selecting a hazardous location electric heater refer to Article 500 or other applicable standard referenced in the National Electric Code.

Standard Models

MFG CATALOG NUMBER	MFG MODEL NUMBER	KW	BTUs	VOLTS	PH	AMPS	CONTROL VOLTAGE	TEMP RISE °F	AIR THROW	CFM	RECOM'D MOUNTING HT.	WT. (lbs)
07343502	HLA 12-208160-3.0-24	3	10240	208	1	16.3	24	16.5	24'	580	8'	167
07340002	HLA 12-208360-3.0-24	3	10240	208	3	9.8	24	16.5	24'	580	8'	167
07340102	HLA 12-240160-3.0-24	3	10240	240	1	14.8	24	16.5	24'	580	8'	167
07340202	HLA 12-240360-3.0-24	3	10240	240	3	8.6	24	16.5	24'	580	8'	167
07340302	HLA 12-480360-3.0-24	3	10240	480	3	4.3	24	16.5	24'	580	8'	167
07343602	HLA 12-208160-5.0-24	5	17100	208	1	26	24	27.6	24'	580	8'	167
07340502	HLA 12-208360-5.0-24	5	17100	208	3	15.4	24	27.6	24'	580	8'	167
07340602	HLA 12-240160-5.0-24	5	17100	240	1	23.1	24	27.6	24'	580	8'	167
07340702	HLA 12-240360-5.0-24	5	17100	240	3	13.4	24	27.6	24'	580	8'	167
07340802	HLA 12-480360-5.0-24	5	17100	480	3	6.7	24	27.6	24'	580	8'	167
07343702	HLA 12-208160-7.5-24	7.5	25600	208	1	38	24	41.4	24'	580	8'	167
07341002	HLA 12-208360-7.5-24	7.5	25600	208	3	22.3	24	41.4	24'	580	8'	167
07341102	HLA 12-240160-7.5-24	7.5	25600	240	1	33.6	24	41.4	24'	580	8'	167
07341202	HLA 12-240360-7.5-24	7.5	25600	240	3	19.4	24	41.4	24'	580	8'	167
07341302	HLA 12-480360-7.5-24	7.5	25600	480	3	9.7	24	41.4	24'	580	8'	167
07341502	HLA 16-208360-10.0-24	10	34150	208	3	29.3	24	21.7	40'	1500	10'	193
07341602	HLA 16-240160-10.0-24	10	34150	240	1	44	24	21.7	40'	1500	10'	193
07341702	HLA 16-240360-10.0-24	10	34150	240	3	25.5	24	21.7	40'	1500	10'	193
07341802	HLA 16-480360-10.0-24	10	34150	480	3	12.7	24	21.7	40'	1500	10'	193
07342002	HLA 20-208360-15.0-24	15	51200	208	3	43.5	24	19.2	43'	2450	13'	193
07342102	HLA 20-240360-15.0-24	15	51200	240	3	38.1	24	19.2	43'	2450	13'	193
07342202	HLA 20-480360-15.0-24	15	51200	480	3	19	24	19.2	43'	2450	13'	193
07342302	HLA 20-600360-15.0-24	15	51200	600	3	15.2	24	19.2	43'	2450	13'	193
07342402	HLA 20-480360-20.0-24	20	68300	480	3	25.1	24	26.2	43'	2450	13'	225
07342502	HLA 20-600360-20.0-24	20	68300	600	3	20	24	26.2	43'	2450	13'	225
07342602	HLA 20-480360-25.0-24	25	85400	480	3	31.1	24	32.8	43'	2450	13'	225
07342702	HLA 20-600360-25.0-24	25	85400	600	3	24.9	24	32.8	43'	2450	13'	225

Standard Models Cont.

MFG CATALOG NUMBER	MFG MODEL NUMBER	KW	BTUS	VOLTS	PH	AMPS	CONTROL VOLTAGE	TEMP RISE °F	AIR THROW	CFM	RECOM'D MOUNTING HT.	WT. (lbs)
07244202	HLA2448036030.024	30	102390	480	3	37.53	24	19.5	65'	4900	15'	362
07244302	HLA2448036035.024	35	119455	480	3	43.54	24	22.5	65'	4900	15'	362
07244402	HLA2848036038.624	38.6	131742	480	3	47.9	24	21	85'	5800	18'	362

HLA Series Hazardous Location Fan Forced Unit Heater

Mounting Bracket Kits

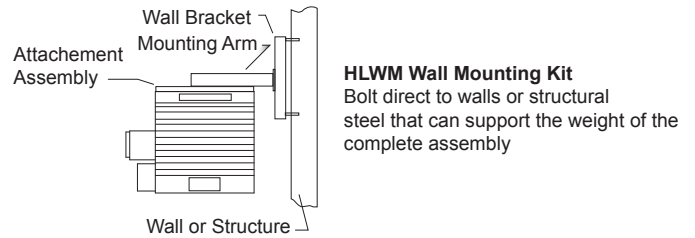
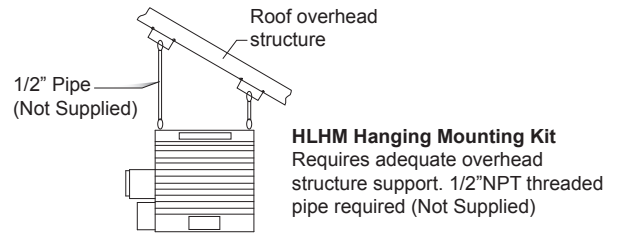
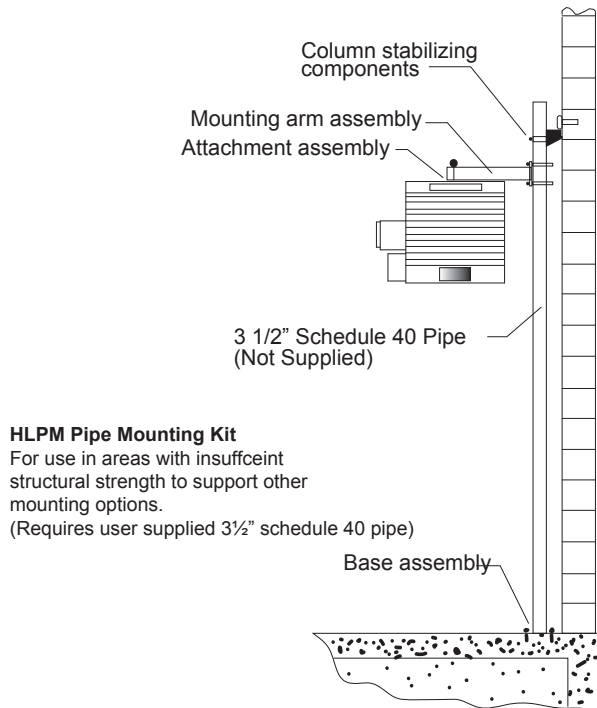

Mounting Bracket Kits

MFG CATALOG NUMBER	MFG MODEL NUMBER	USE WITH HEATERS	WT. (LBS)
07342802	HLP37	3.0 kW - 7.5 kW	37
07342902	HLP10	10.0 kW	38
07343002	HLP1525	15.0 kW - 25.0 kW	40
07343102	HLHM	ALL	5
07343202	HLWM37	3.0 kW - 7.5 kW	27
07343302	HLWM10	10.0 kW	28
07343402	HLWM1525	15.0 kW - 25.0 kW	29
07245402	HLWM24	30.0 kW - 35.0 kW	34
07245502	HLWM28	38.6 kW	35
07245602	HLP24	30.0 - 35.0 kW	43
07245702	HLP28	38.6 kW	44
07245802	HLHM2428	30.0 - 38.6 kW	6